

© 1967 BY AMP INCORPORATED. ALL RIGHTS RESERVED. AMP PRODUCTS COVERED BY PATENTS AND/OR PATENTS PENDING.

REVISIONS			
ZONE	LTR	DESCRIPTION	DATE
	R	REV. PER EON. DF 0378	5-6-85
	S	REV. DF-0501	7-88
		0500-2117-94	

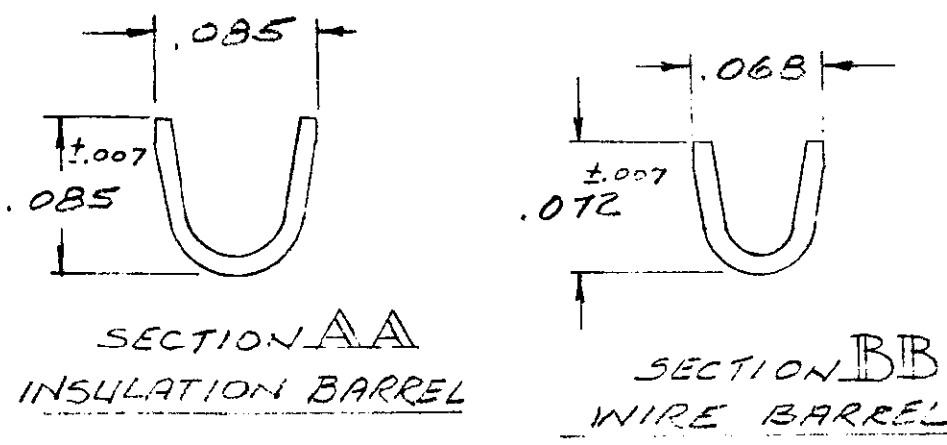
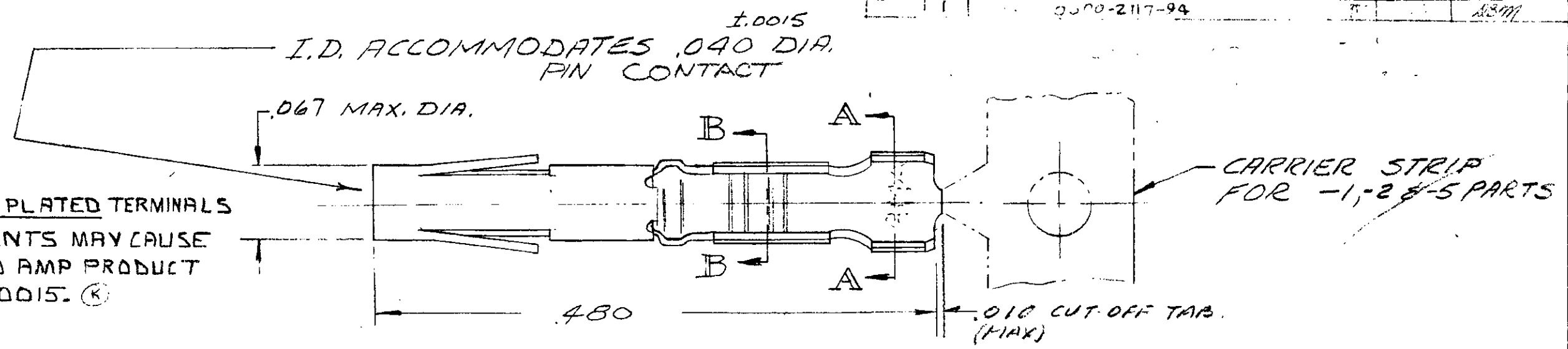

□ INDICATES WIRE RANGE OF 20, 22 & 24 AWG.  
 WIRE RANGE: 20, 22, & 24 AWG.  
 INSULATION RANGE: .062 MAX.  
 HAND TOOL: AMP # 90260-1.  
 EXTRACTION TOOL: AMP # 91038-3.  
 INSERTION TOOL: AMP # 91042-1.

203802-7 **OBsolete** EXCEPT:  
 -8 **OBsolete** EXCEPT:  
 1. SAME AS -5 EXCEPT:  
 2. REVERSE REELED FOR STANDARD APPLICATOR. (A) (K)

- 203802-1 1. AS SHOWN:
- 2. STRIP PART
- 3. BODY - BRASS, .000030 AU/.00005 NI.
- 1. SLEEVE, STAINLESS STEEL
- 2 1. SAME AS -1, EXCEPT:
- 2. BODY, SELECTIVE .000030 AU/.000050 NI.
- 3 1. SAME AS -1, EXCEPT:
- 2. LOOSE PIECE PART
- 4 1. SAME AS -2, EXCEPT:
- 2. LOOSE PIECE PART
- OBsolete** AS -1, EXCEPT:
- 2. BODY, TIN PLATED (A) (K)
- 4 1. SAME AS -5, EXCEPT:
- 2. LOOSE PIECE PART (A) (K)

- OBsolete** 1. SAME AS -3 EXCEPT:
- 2. CUSTOMER PART NO. TO BE MARKED ON INNERMOST PACKAGE.
- OBsolete** 1. SAME AS -1 EXCEPT:
- 2. CUSTOMER PART NO. TO BE MARKED ON INNERMOST PACKAGE.

UNLESS OTHERWISE SPECIFIED DIM. ARE IN INCHES. TOLERANCES ON: DECIMALS ± .005 ANGLES ± °	CONTRACT NO.		AMP INCORPORATED HARRISBURG, PENNSYLVANIA	
	DR	59	NAME	
	CHK	P. J. Miller 12-15-67	CONTACT ASSY-SOCKET	
	APPD	W. J. Leagan 12-15-67	SIZE 20 (20-24 GA)	
MATERIAL	SEE CALLOUT	DSGN APPD	SIZE	CODE IDENT NO.
AMP INFO	HEAT TREAT	OTHER APPD	B	00779
FINISH	SEE WORKING NO.	SCALE	H	WT CALC ACTUAL SHEET
				203802