

THIS DRAWING IS UNPUBLISHED
 BY TYCO ELECTRONICS CORPORATION.
 ALL INTERNATIONAL RIGHTS RESERVED.

LOC	DISC	REVISIONS				
		P	LTR	DATE	DWN	APVD
		B		13Aug09	S.A.	ML
		DESCRIPTION				
		ECR-09-018170				

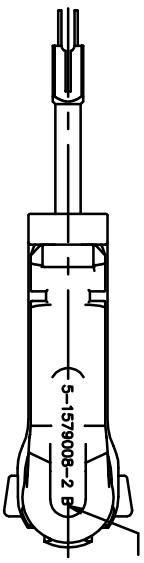

ITEM NUMBER
 Art.-Nr. H=3mm

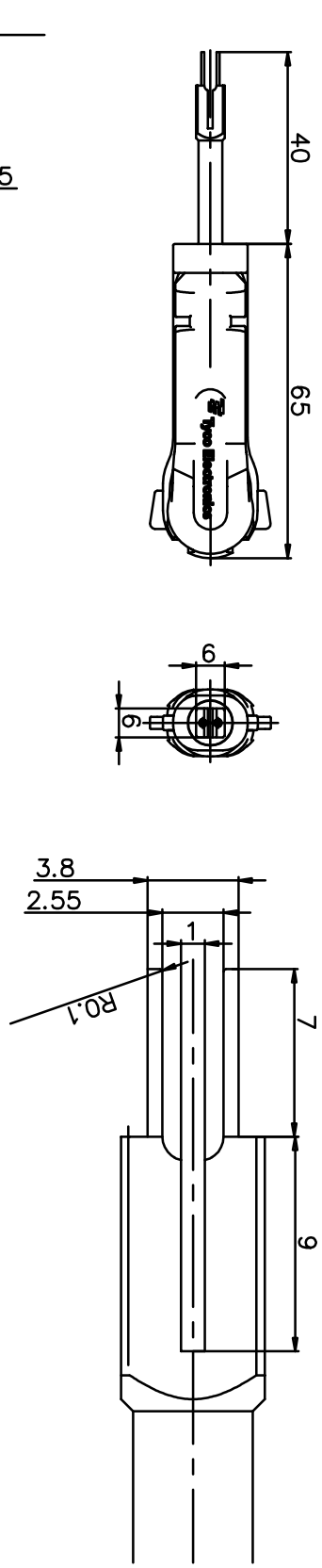
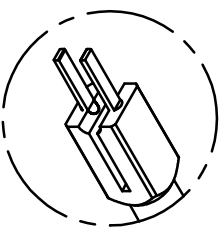

2:1
 A

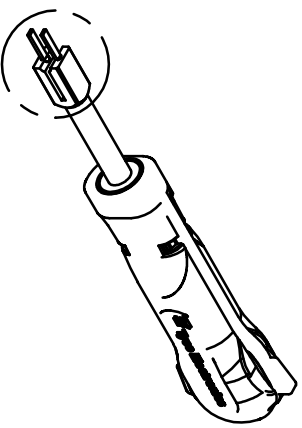

A

APPLICATION RANGE / Anwendungsbereich :

FOR HOUSING: 1719334-1
 FOR CONTACT MCON 2.8 : 1719840-1

THIS DRAWING IS A CONTROLLED DOCUMENT.

DIMENSIONS:		TOLERANCES UNLESS OTHERWISE SPECIFIED:		APPROVED		DATE		NAME	
mm		0 PLC	± .	DWN	S. Samskog	13.08.2009		CHK	G. Stegmayer
		1 PLC	± .	APVD	G. Stegmayer	13.08.2009			
		2 PLC	± .	PRODUCT SPEC					
		3 PLC	± .	APPLICATION SPEC					
		ANGLES	± .	WEIGHT					
			± .	0,000kg					

Tyco Electronics
 Tyco Electronics AMP GmbH
 64685 Bensheim in Germany

EXTRACTION TOOL
 Entriegelungswerkzeug

SIZE: A3
 CAGE CODE: 00779
 DRAWING NO: 5-1579008-2

CUSTOMER DRAWING		SCALE		SHEET		REV	
		1:1		1	OF 1		B
						RESTRICTED TO	

THIS INFORMATION IS CONFIDENTIAL AND PROPRIETARY TO TYCO ELECTRONICS CORPORATION AND SHALL BE KEPT AS SUCH. ANY DISCLOSURE OR REPRODUCTION OF THIS INFORMATION WITHOUT THE WRITTEN PERMISSION OF TYCO ELECTRONICS CORPORATION IS STRICTLY PROHIBITED. HARRISBURG, PENNSYLVANIA USA.

DIESES ZEICHNUNGSDOKUMENT WIRD DURCH TYCO ELECTRONICS CORPORATION KONTROLLIERT. ABERWENIGEN DIE DEN TECHNISCHEN FORTSCHRITT DIENEN, SIND VERBEHALTEN DEN JEWEILS LETZTGÜLTIGEN HENGERUNGSSTAND ERFAHREN SIE AUF ANFRAGE.

THIS DRAWING IS A CONTROLLED DOCUMENT FOR TYCO ELECTRONICS CORPORATION. IT IS SUBJECT TO CHANGE AND THE CONTROLLING ENGINEERING ORGANIZATION SHOULD BE CONTACTED FOR THE LATEST REVISION.