

# mikromedia

## board for PIC18FJ

Compact development system rich with on-board peripherals for all-round multimedia development on PIC18F87J50

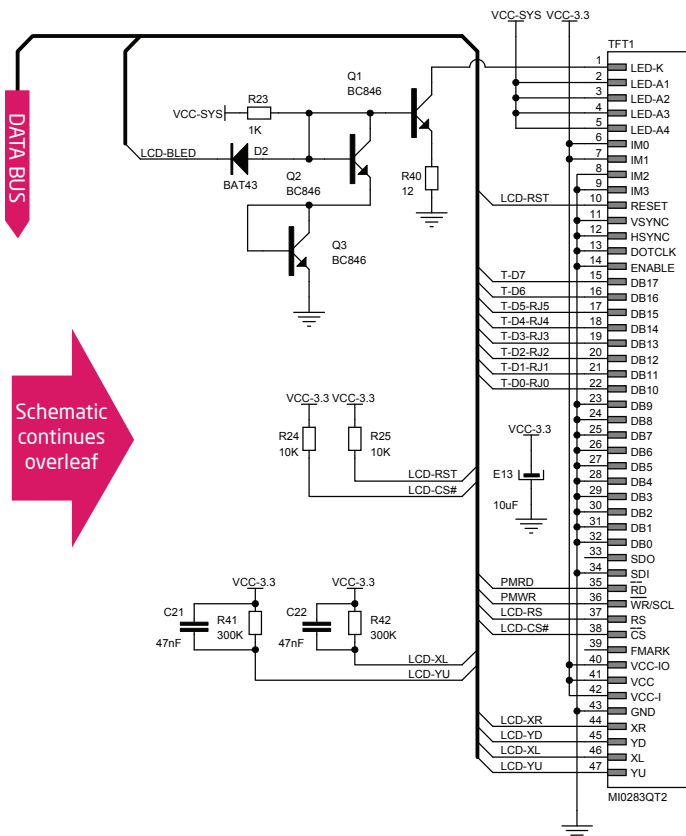

DATA BUS

Schematic continues overleaf

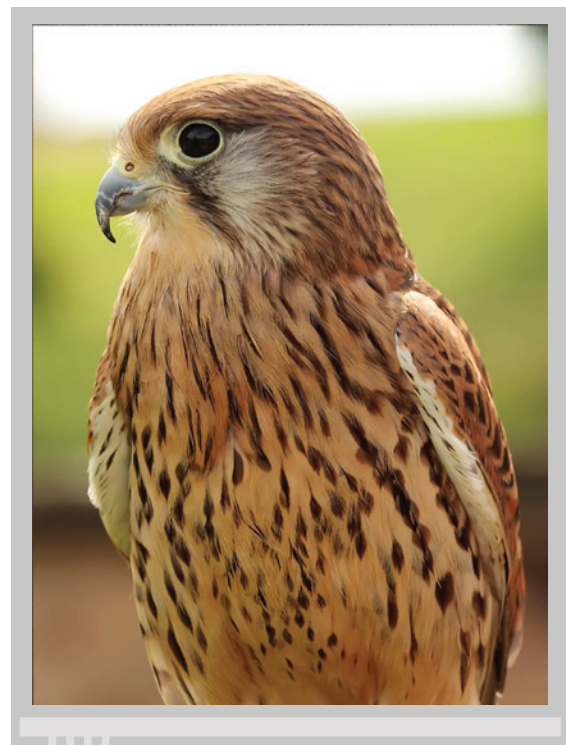

TFT 320x240 display with 262.144 colors

HW REW. 1.10

DATA BUS

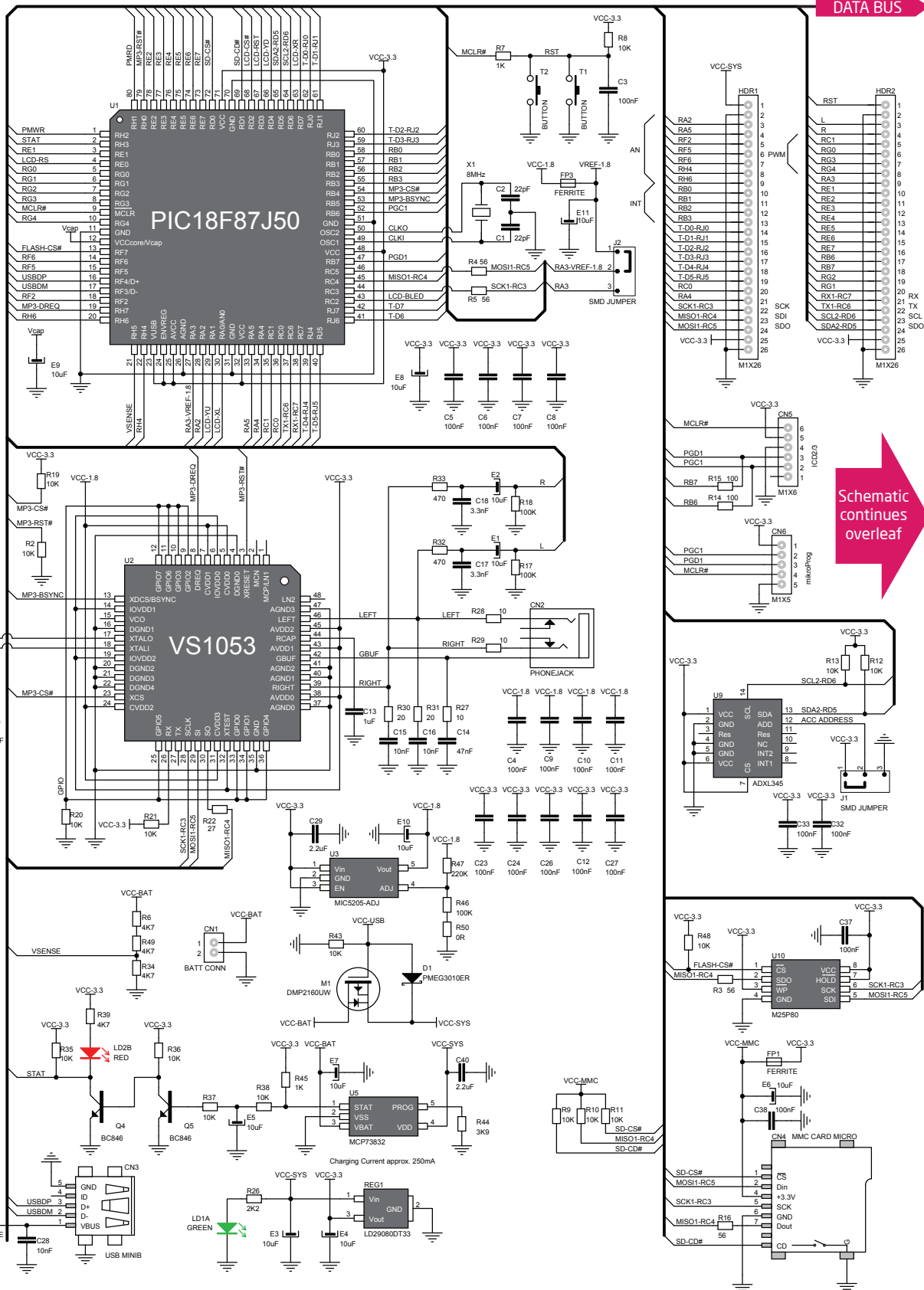

Schematic continues overleaf

If you are experiencing some problems with any of our products or just need additional information, please contact our technical support: [www.mikroe.com/en/support](http://www.mikroe.com/en/support)