

Geometry according MIL-STD-348B

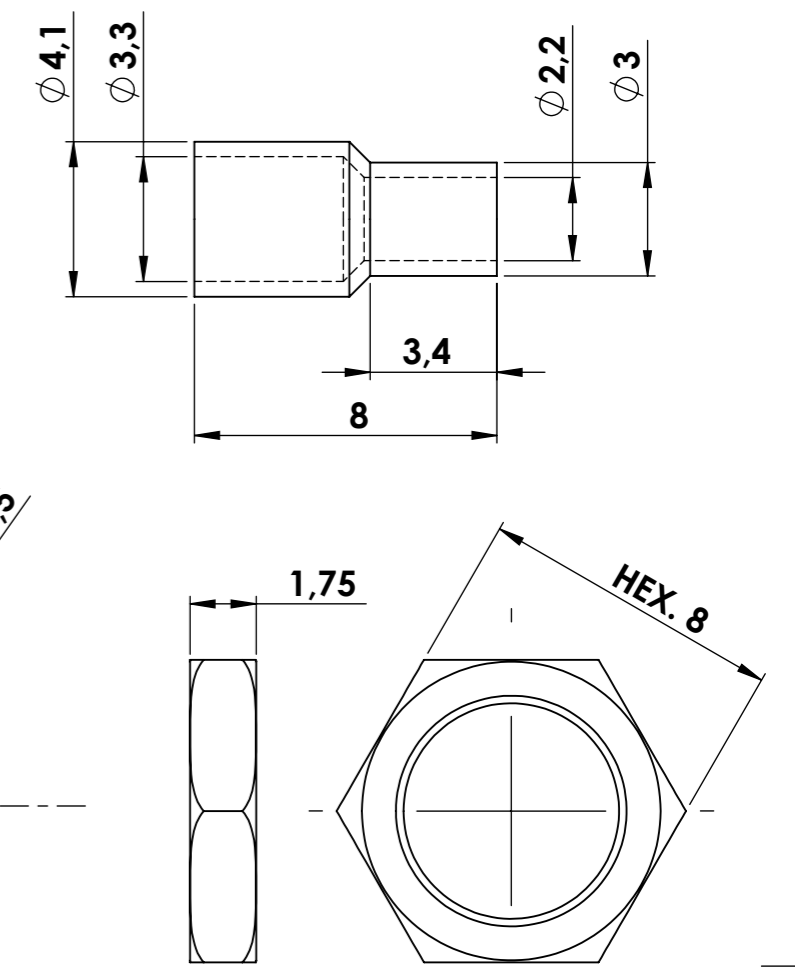
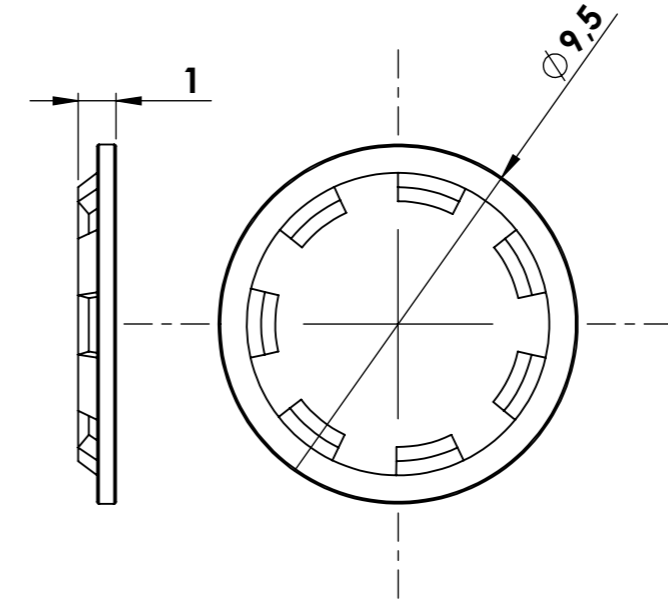
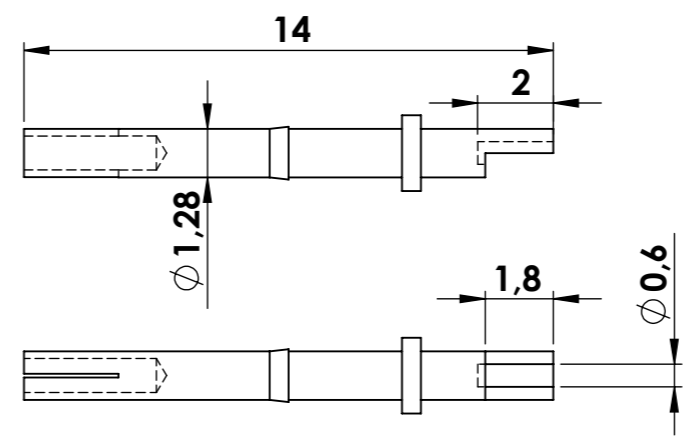
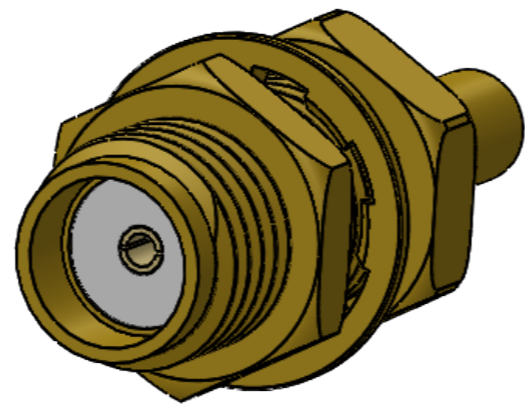
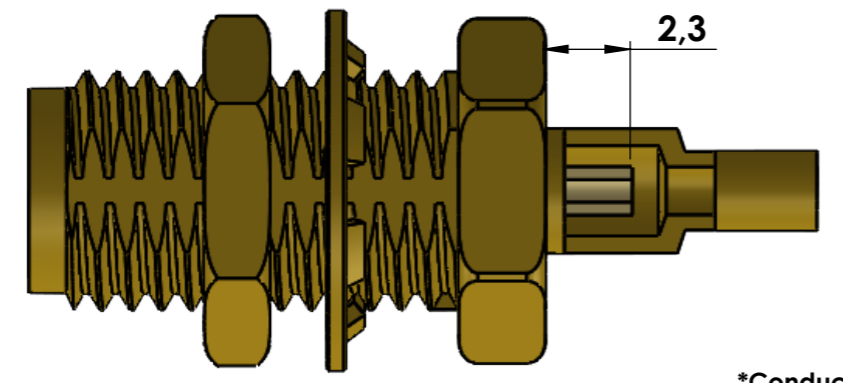

ITEM NO.	PART NUMBER	Material	Finish	QTY.
1	C485G Body Ver 1.0	Brass	Gold	1
2	C485G Ferrule Ver 1.0	Brass	Gold	1
3	C485G Washer Ver 1.0	Brass	Gold	1
4	C485G Nut Ver 1.0	Brass	Gold	1
5	C485G Insulator Ver 1.0	Teflon		1
6	C485G Pin Ver 1.0	Brass	Gold	1

AUTHOR	Ing. Pangrač B.		DEBUR AND BREAK SHARP EDGES
DATE	5.2.2020		
CHECKED BY		ISO 2768-mK	
APPROVED		WEIGHT:	
MATERIAL:		FINISH:	

2J Antennas
www.2j-antennas.com

NOTES:
Stock No.: 13539
SMA female BH for MC081, MC113, MC132, MC137, RG178, Gold

TITLE:	C485G Ver 1.0	REVISION	-
DWG NO.	2J-CO-C485G-1.0-01		A3

*Conductor soldering / Pájkovanie vodiča
 *Braid soldering / Pájkovanie tienenia