

TE CONNECTIVITY ORDER-Nr.	TE CONNECTIVITY ORDER-Nr.	REV.	MATERIAL	SURFACE	DGB [mm ²]	WIRE CRIMP	INSUL.-CRIMP	WIRE CRIMP HEIGHT CH	APPLICATION TOOL	HAND TOOL	A	B	C
1-929968-0	1-962972-0	M	CuFe2	2	>1.0-2.5	E = 3.6	H = 5.0	2.5mm ² = 1.97	MQC-Applicator	734289-2	4	6.9	8.5
929968-9	962972-9	M	CuNiSi	3	FLR	G = 3.8	K = 5.0	2.0mm ² = 1.82	2-878486-2				
929968-8	962972-8	M	CuFe2	1		D _{cr} = 1.7	D = 3.6	1.5mm ² = 1.67					
929968-7	962972-7	M	CuNiSi	2									
929968-4	962972-4	M	CuFe2	1									
929968-1	962972-1	M	CuNiSi	1									
1-929967-4	1-962971-4	A	CuNiSi	4	0.5-1.0	E = 2.6	H = 4.8	1.0mm ² = 1.45	MQC-Applicator	734289-1	3	5.4	7
1-929967-0	1-962971-0	M	CuFe2	3	FLR	G = 2.8	K = 4.8	0.75mm ² = 1.36	2-878485-2				
929967-9	962971-9	M	CuNiSi	2		D _{cr} = 1.1	D = 3.2	0.5mm ² = 1.27					
929967-8	962971-8	M	CuFe2	1									
929967-7	962971-7	M	CuNiSi	2									
929967-4	962971-4	M	CuFe2	1									
929967-1	962971-1	M	CuNiSi	1									
1-929966-0	1-962970-0	M	CuFe2	2	0.2-0.4	E = 2.1	H = 4.5	0.35mm ² = 1.11	MQC-Applicator	734289-1	3	5.4	7
929966-9	962970-9	M	CuNiSi	3	FLR	G = 2.1	K = 4.5		2-878484-2				
929966-8	962970-8	M	CuFe2	1		D _{cr} = 0.8	D = 3.2						
929966-7	962970-7	M	CuNiSi	2									
929966-4	962970-4	M	CuFe2	1									
929966-1	962970-1	M	CuNiSi	1									

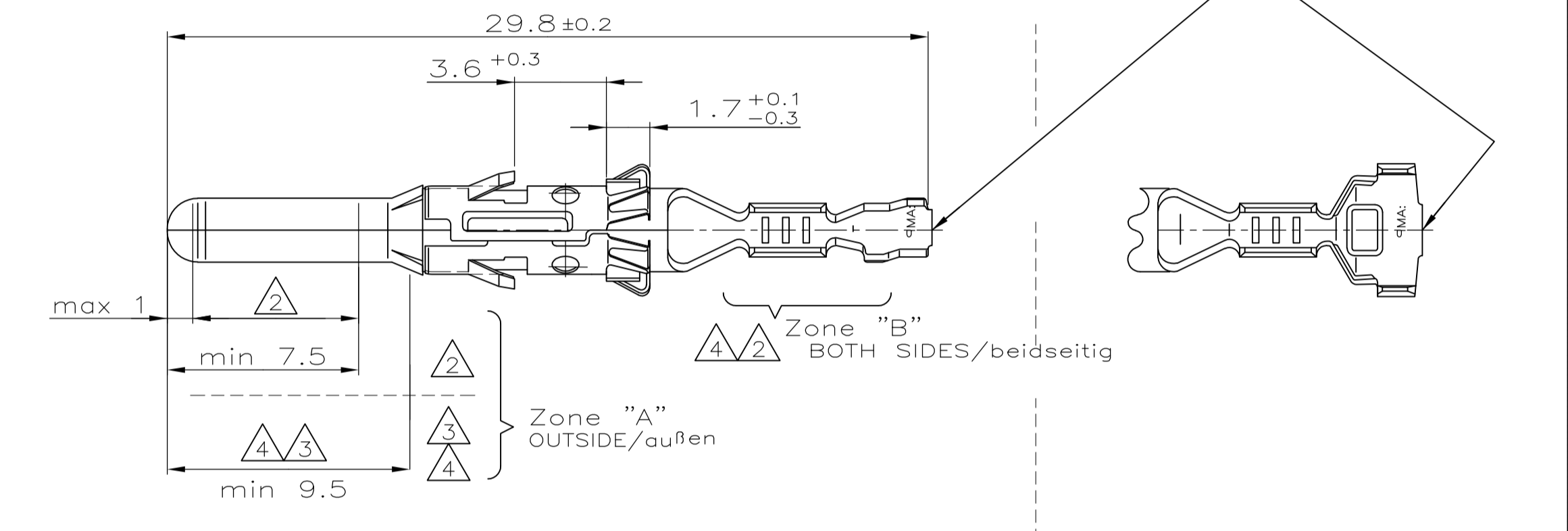

REMARKS
Bemerkungen

1 **PRE TINNED** 1-2µm
vorverzint

2 **ZONE "A": MIN 0.8µm ELECTROPL. Au OVER MIN 1.3µm ELECTROPL. Ni LAYER**
min 0.8µm galv. Au über min 1.3µm galv. Ni
ZONE "B": 1-2µm ELECTROPL. Sn OVER MIN 0.1µm ELECTROPL. Ni
1-2µm galv. Sn über min 0.1µm galv. Ni
REST: min 0.1µm ELECTROPL. Ni
min 0.1µm galv. Ni

3 **ZONE "A": MIN 3µm ELECTROPL. Ag**
min 3µm galv. Ag
REST: min 0.5µm ELECTROPL. Ag
min 0.5µm galv. Ag

4 **ZONE "A": MIN 3µm ELECTROPL. Ag**
min 3µm galv. Ag
ZONE "B": 1-3µm ELECTROPL. Sn
1-3µm galv. Sn
REST: SILVER OR TIN ALLOWED IN TRANSITION AREAS.OVERLAPPING LAYERS
AND PLAIN SURFACES ARE NOT ALLOWED.
Silber oder Zinn im Übergangsbereich erlaubt.
überlagernde Schichten oder blanke Stellen sind nicht erlaubt.

5 **AT AREA OF TOP OPENING PERMITTED**
Im Bereich der Spitze Öffnung zulässig

6 **AVAILABILITY MUST BE CHECKED BY TE CONNECTIVITY**
Verfügbarkeit ist von TE CONNECTIVITY zu prüfen

TE CONNECTIVITY ORDER-Nr.	TE CONNECTIVITY ORDER-Nr.	REV.	MATERIAL	SURFACE	DGB [mm ²]	WIRE CRIMP	INSUL.-CRIMP	WIRE CRIMP HEIGHT CH	APPLICATION TOOL	HAND TOOL	A	B	C
1-929965-0	1-962969-0	J	CuFe2	3	>2.5-4.0	E = 4.3	H = 5.4	4.0mm ² = 2.30	MQC-Applicator	734285-3	4	5.5	8.5
929965-9	962969-9	J	CuNiSi	2	FLR	G = 4.5	K = 5.6	3.0mm ² = 2.05	2-878483-2				
929965-8	962969-8	J	CuFe2	1		D _{cr} = 2.4	D = 3.2						
929965-7	962969-7	J	CuNiSi	2									
929965-4	962969-4	J	CuFe2	1									
929965-1	962969-1	J	CuNiSi	1									
1-929964-0	1-962968-0	J	CuFe2	3	>1.0-2.5	E = 3.6	H = 4.3	2.5mm ² = 1.97	MQC-Applicator	734285-2	4	5.5	8.5
929964-9	962968-9	J	CuNiSi	2	FLR	G = 3.8	K = 4.5	2.0mm ² = 1.82	2-878482-2				
929964-8	962968-8	J	CuFe2	1		D _{cr} = 1.7	D = 2.6	1.5mm ² = 1.67					
929964-7	962968-7	J	CuNiSi	2				1.25mm ² = 1.60					
929964-4	962968-4	J	CuFe2	1									
929964-1	962968-1	J	CuNiSi	1									
1-929963-0	1-962967-0	L	CuFe2	3	0.5-1.0	E = 2.6	H = 3.2	1.0mm ² = 1.45	MQC-Applicator	734285-1	3	4.5	7
929963-9	962967-9	L	CuNiSi	2	FLR	G = 2.8	K = 3.4	0.75mm ² = 1.36	2-878481-2				
929963-8	962967-8	L	CuFe2	1		D _{cr} = 1.1	D = 1.8	0.5mm ² = 1.27					
929963-7	962967-7	L	CuNiSi	2									
929963-4	962967-4	L	CuFe2	1									
929963-1	962967-1	L	CuNiSi	1									
1-929962-0	1-962966-0	J	CuFe2	2	0.2-0.4	E = 2.1	H = 2.5	0.35mm ² = 1.11	MQC-Applicator	734285-1	3	4.5	7
929962-9	962966-9	J	CuNiSi	3	FLR	G = 2.1	K = 2.5	0.25mm ² = 1.07	2-878480-2				
929962-8	962966-8	J	CuFe2	1		D _{cr} = 0.8	D = 1.4	0.2mm ² = 1.05					
929962-7	962966-7	J	CuNiSi	2									
929962-4	962966-4	J	CuFe2	1									
929962-1	962966-1	J	CuNiSi	1									

TE CONNECTIVITY ORDER-Nr.	TE CONNECTIVITY ORDER-Nr.	REV.	MATERIAL	SURFACE	DGB [mm ²]	WIRE CRIMP	INSUL.-CRIMP	WIRE CRIMP HEIGHT CH	APPLICATION TOOL	HAND TOOL	A	B	C	
STRIP FORM	LOOSE PIECE		Werkstoff	Oberfläche	[mm ²]	Drahtcrimp	Isol.-Crimp	Drahtcrimp-Höhe CH	Anschlag-WKZ	Handzange				
Bandware	Einzelzuführung					CRIMP DIMENSION (mm) Crimpabmessungen (mm)			EXTRACTION TOOL Ausdrückwerkzeug Nr.: 872070-1					

THIS DRAWING IS A CONTROLLED DOCUMENT. DIESE ZEICHNUNG IST EIN KONTROLLIERTES DOKUMENT.

DIMENSIONS: DIMENSIONEN mm	TOLERANCES UNLESS OTHERWISE SPECIFIED: ALLE TOLERANZEN UNLESS OTHERWISE SPECIFIED: ± 0.15 mm	DWG	25-JUN-2001
MATERIAL SEE TABLE	FINISH/OBERFLÄCHE/FARBE SEE TABLE	NAME	TE Connectivity
WEIGHT 0.85 g	SCALE 5:1	PRODUCT SPEC 108-18027	DIA. 2.5MM PIN CONTACT DIA 2.5mm Stiftkontakt
CUSTOMER DRAWING /KUNDENZEICHNUNG	SCALE 5:1	APPLICATION SPEC 114-18020	RESTRICTED TO SURFAC

APVD: J. Granzow

DATE: 28DEC11

REV: HMR