

X4 DATA SHEET

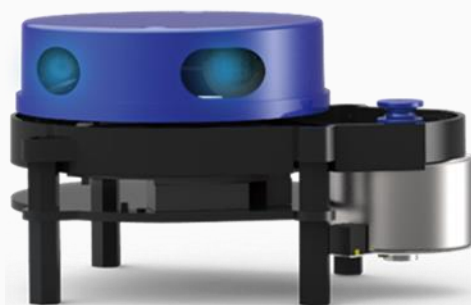

CONTENTS

1	PRODUCT OVERVIEW	1
1.1	Product Features	1
1.2	Applications	1
1.3	Installation and Dimensions	1
2	SPECIFICATIONS	2
2.1	Performance Parameter	2
2.2	Electrical Parameter	2
2.3	Interface Definition	2
2.4	Data Communication	3
2.5	Motor Control	4
2.6	Optical Characteristic.....	4
2.7	Polar Coordinate System Definition	4
2.8	Others.....	5
3	DEVELOPMENT AND SUPPORT	5
4	REVISE	6

1 PRODUCT OVERVIEW

YDLIDAR X4 is a 360 degrees 2D LiDAR (hereinafter referred to as X4) developed by YDLIDAR team. Based on the principle of Triangulation, it is equipped with related optics, electricity, and algorithm design to achieve high-frequency and high-precision distance measurement. The mechanical structure rotates 360 degrees to continuously output the angle information as well as the point cloud data of the scanning environment while ranging.

1.1 Product Features

- 360 degrees scan ranging
- High accuracy, stable performance
- Wide measuring range
- Strong resistance to ambient light interference
- Low power consumption, small size, stable performance and long service life
- Class I eye safety
- Motor speed is adjustable, the proposed speed is 6~12Hz
- High-speed ranging, ranging frequency up to 5KHz

1.2 Applications

- Robot navigation and obstacle avoidance
- Robot ROS teaching and research
- Regional security
- Environmental scanning and 3D reconstruction
- Navigation and obstacle avoidance of home robots/ robot vacuum cleaners

1.3 Installation and Dimensions

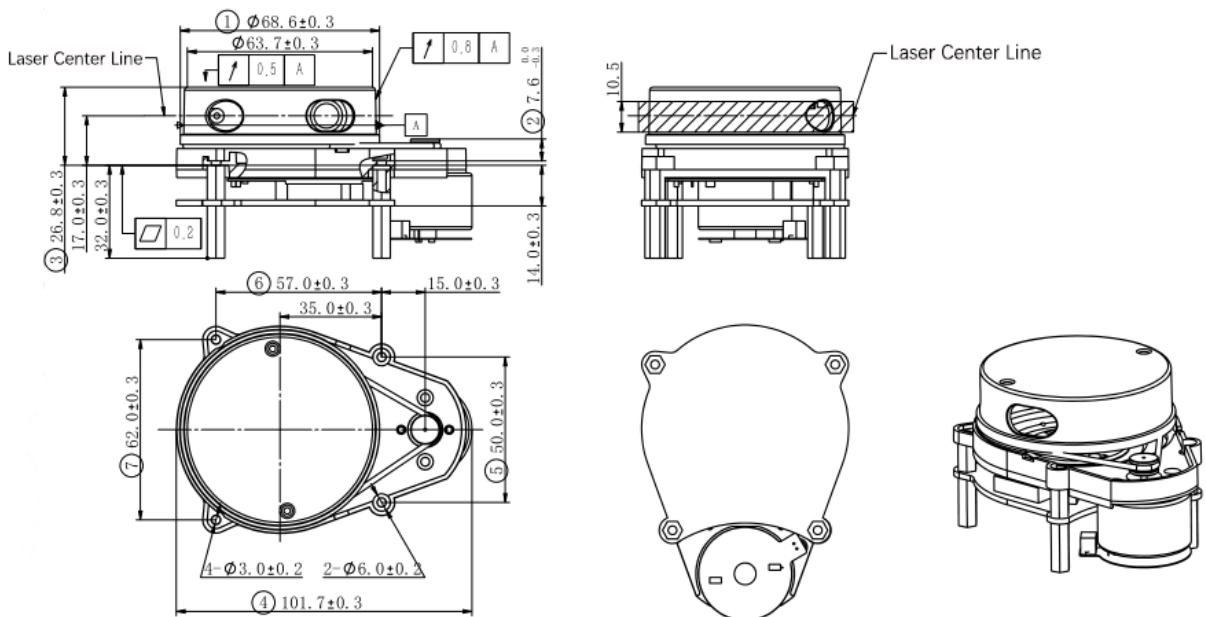

FIG 1 YDLIDAR X4 INSTALLATION AND MECHANICAL DIMENSIONS

2 SPECIFICATIONS

2.1 Performance Parameter

CHART 1 YDLIDAR X4 PRODUCT PARAMETER

Item	Min	Typical	Max	Unit	Remarks
Ranging frequency	/	5000	/	Hz	Ranging 5000 times per second
Motor frequency	6	/	12	Hz	PWM or voltage speed regulation
Ranging distance	0.12	/	10	m	Indoor environment with 80% Reflectivity
Field of view	/	0-360	/	Deg	/
Systematic error	/	2	/	cm	Range≤1m
Relative error	/	3.5%	/	/	1m<Range ≤6m
Tilt angle	0.25	1	1.75	Deg	/
Angle resolution	0.43 (frequency@6 Hz)	0.50 (frequency@7 Hz)	0.86 (frequency @12Hz)	Deg	Different motor frequency

Note 1: The measurement range and relative accuracy above are the factory FQC standard value based on 80% reflectivity object.

Note 2: The relative error value indicates the accuracy of the Lidar measurement. Relative error (mean value) = (average measured distance-actual distance)/actual distance *100%, sample size: 100pcs.

Note 3: Lidar is a precision device. Please avoid using Lidar under high or low temperature or strong vibration situation, which might cause an exceeded relative error.

2.2 Electrical Parameter

CHART 2 YDLIDAR X4 ELECTRICAL PARAMETER

Item	Min	Typical	Max	Unit	Remarks
Supply voltage	4.8	5	5.2	V	Excessive voltage might damage the Lidar while low affect normal performance
Supply current	1000	/	/	mA	Instantaneous peak current at start-up
Working current	/	350	500	mA	System work, motor rotation speed=7Hz

2.3 Interface Definition

X4 provides PH2.0-8P receptacle to realize power and data communication function.

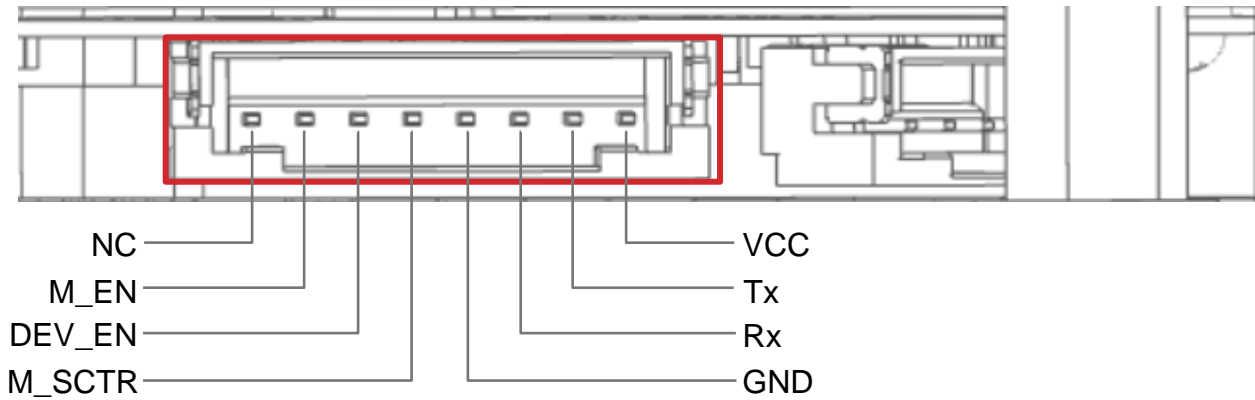

FIG 2 YDLIDAR X4 INTERFACES

CHART 3 YDLIDAR X4 INTERFACE DEFINITION

Pin	Type	Description	Defaults	Range	Remarks
VCC	Power supply	Positive	5V	4.8V-5.2V	/
Tx	Output	System serial port output	/	/	Data stream: LiDAR→Peripherals
Rx	Input	System serial port input	/	/	Data stream: Peripherals→LiDAR
GND	Power supply	Negative	0V	0V	/
M_EN	Input	Motor enables control terminal	3.3V	0V-3.3V	High level enables
DEV_EN	Input	Ranging enable control terminal	3.3V	0V-3.3V	High level enables
M_SCTR	Input	Motor speed control terminal	1.8V	0V-3.3V	Voltage speed regulation or PWM speed regulation
NC	/	Reserve pin	/	/	/

2.4 Data Communication

With a 3.3V level serial port (UART), users can connect the external system and the product through the physical interface. After that, users can obtain the real-time scanned point cloud data, device information as well as device status. The communication protocol of parameters are as follows:

CHART 4 YDLIDAR X4 SERIAL PORT SPECIFICATION

Item	Min	Typical	Max	Unit	Remarks
Baud rate	/	128000	/	bps	8-bit data bit,1 stop bit, no parity
High signal level	2.4	3.3	3.5	V	/
Low signal level	0	0	0.6	V	/

2.5 Motor Control

X4 has its own motor driver with motor speed control function. The peripheral can control the X4 motor by inputting control signals through the M_EN and M_SCTR pin in the interface. M_EN is the enable signal of the motor, high-level enable; M_SCTR is the motor speed control signal, which can be adjusted by voltage and can also be debugged by PWM wave. The lower the voltage/the smaller the PWM duty cycle, the higher the motor speed, 0V/ The speed is maximum when the duty cycle is 0%.

For example: M_EN is high level, M_SCTR input voltage is 0V, and the motor rotates at the highest speed.

Among them, the PWM signal of M_CTR has the following requirements:

CHART 5 YDLIDAR X4 MOTOR PWM SIGNAL SPECIFICATION

Prpjct	Min	Typical	Max	Unit	Remarks
PWM frequency	/	10	/	KHz	PWM is a square wave signal
Duty cycle range	50%	85%	100%	/	The larger the duty cycle, the faster the speed

2.6 Optical Characteristic

X4 uses an infrared laser that meets FDA Class I eye safety standards. The laser and optical lens finish the transmission and reception of the laser signal to achieve high-frequency ranging while working. To ensure system ranging performance, please keep the laser and optical lens clean. The detailed optical parameters are as follows:

CHART 6 YDLIDAR X4 LASER OPTICAL PARAMETERS

Item	Min	Typical	Max	Unit	Remarks
Laser wavelength	775	793	800	nm	Infrared band
FDA	 Class I				

2.7 Polar Coordinate System Definition

In order to facilitate secondary development, X4 internally defines a polar coordinate system. The polar coordinates of the system take the center of the rotating core of X4 as the pole, and the specified Angle is positive clockwise. The zero Angle is located directly in front of the X4 motor. Due to individual differences, there is a deviation of +/-3°, as shown in the figure:

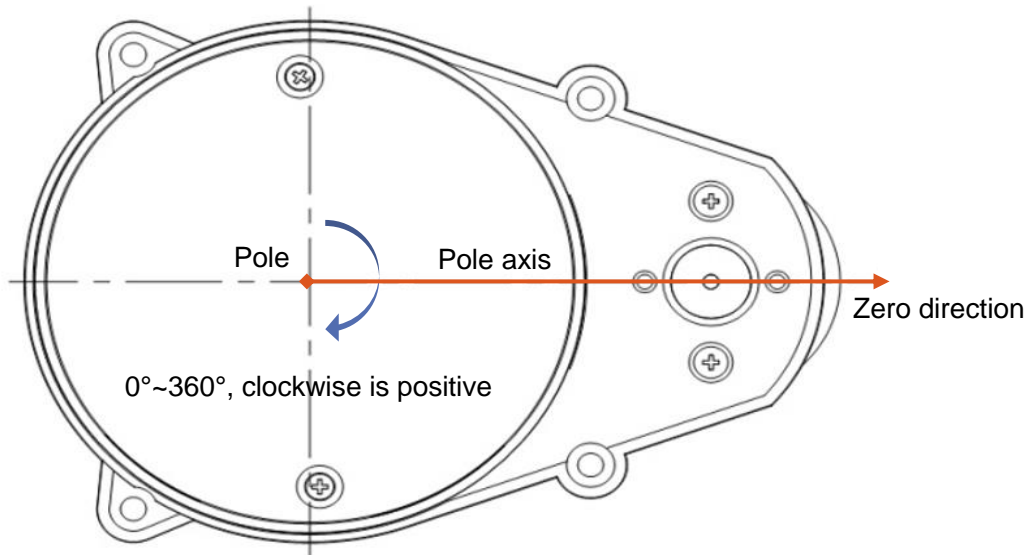

FIG 3 YDLIDAR X4 POLAR COORDINATE SYSTEM DEFINITION

2.8 Others

CHART 7 YDLIDAR X4 OTHERS

Item	Min	Typical	Max	Unit	Remarks
Operating temperature	0	20	40	°C	No condensation
Storage temperature	-10	/	60	°C	With package
Lighting environment	0	550	2000	Lux	For reference only
weight	/	180	/	g	N.W.

3 DEVELOPMENT AND SUPPORT

X4 provides a wealth of software interfaces, which can realize the motor enabling control, speed control, range unit enabling control and output control of the system. On this basis, users can also implement the power control and scan control purpose.

Also, the 3D model of X4 is disclosed. YDLIDAR provides the graphics debugging Workstation under Windows, as well as the corresponding SDK and ROS development kit to users, which could be downloaded from our website: <https://www.ydlidar.com/>.

In order to facilitate users' development, X4 development manual, SDK development manual and ROS user manual are also provided. Please download them from [our website](#).

4 REVISE

Date	Version	Content
2018-06-20	1.0	Compose a first draft
2021-11-15	1.1	Update electrical parameters and serial port specification; add tilt angle