

# 2J7504B 2J7504M (DATASHEET)

<b>Type</b>	Penta band antenna
<b>Frequencies</b>	AMPS (824-894 MHz) GSM (900 MHz) DCS (1800 MHz) PCS (1900 MHz) 3G (UMTS 2.1 GHz)
<b>Mounting</b>	B - Body Mount M – Magnetic Mount
<b>Revision</b>	01



## 1. PRODUCT SELECTOR

- 2J7504B - Body mount version
- 2J7504M - Magnetic mount version

## 2. SPECIFICATION

### 2.1. Electrical Specifications

#### Mobile (Cable 1)

Frequencies	AMPS (824-894 MHz) GSM (900 MHz) DCS (1800 MHz) PCS (1900 MHz) 3G (UMTS 2.1 GHz)
Impedance	50 Ohms
Polarization	Linear
Gain	0dBi Max.
VSWR	<2:1
Operating temperature	-40°C to +85°C

### 2.2. Connection Specifications

- Cable 1 (Mobile):
- Connector type: FME
- Cable: RG174U
- Cable length: 250 cm

For different cable length and connector type ask our sales team.

### 2.3. Mechanical Specifications and Dimensions

#### 2.3.1. Body mount

- Material: Base: Zamak / Lid: ABS / Whip: TPE / Gasket: TPE
- Max. dimensions: 60mm x 81mm (D x H)
- Colour: Black (for different colours please ask our sales team)

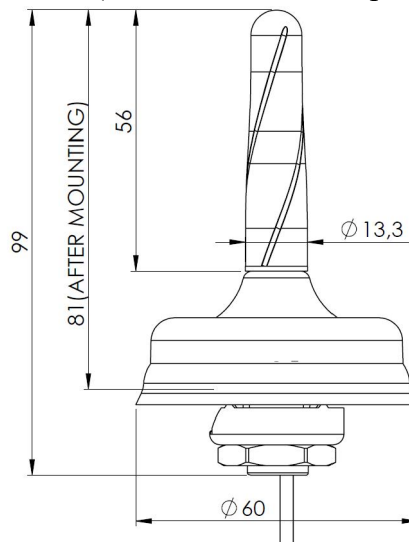

### 2.3.2. Magnetic mount

Material: Base: Zamak / Lid: ABS / Whip: TPE  
 Max. dimensions: 54mm x 80mm (D x H)  
 Colour: Black (for different colours please ask our sales team)

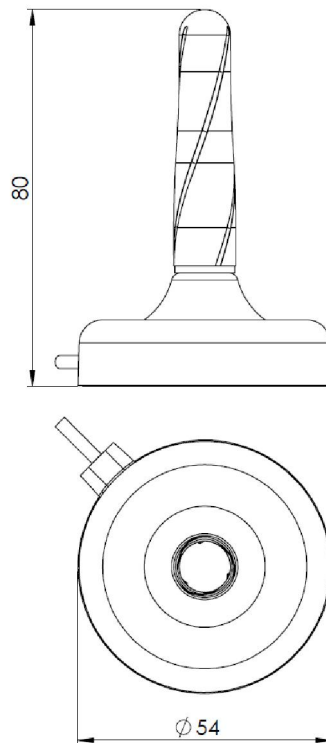

## 3. MEASUREMENT

- Measured on steel plate 30x30cm with RG174 cable length 250cm

SWR (Penta Band)

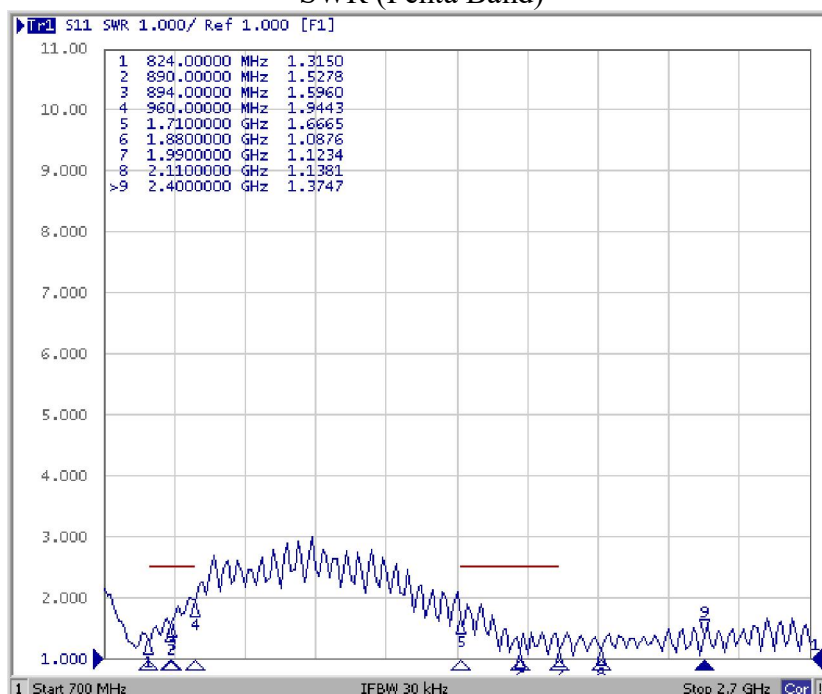

## 4. IMAGES

