

[Products](#)[ioModule](#)[W6100-io](#)

W6100-io

Overview

W6100-io is a compact size network module that includes a W6100 (TCP/IP hardwired chip and PHY embedded).It can be used as a component and no effort is required to interface W6100. The W6100-io an ideal option for users who want to develop their Internet enabling systems rapidly. W6100-io is hardware compatible with W5100s-io and W5500-io.

For the detailed information on implementation of Hardware TCP/IP, refer to the [W6100 Datasheet](#).

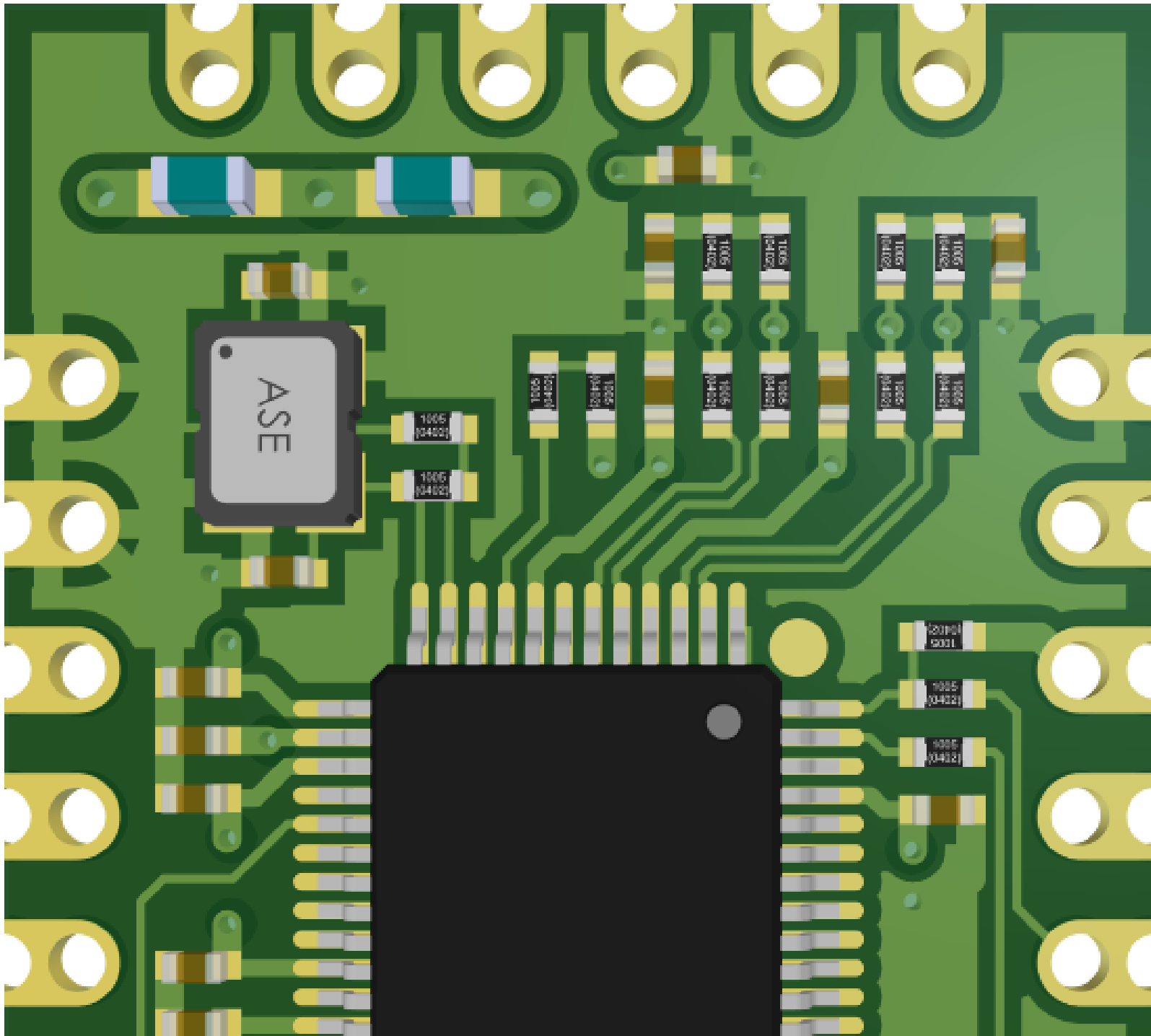

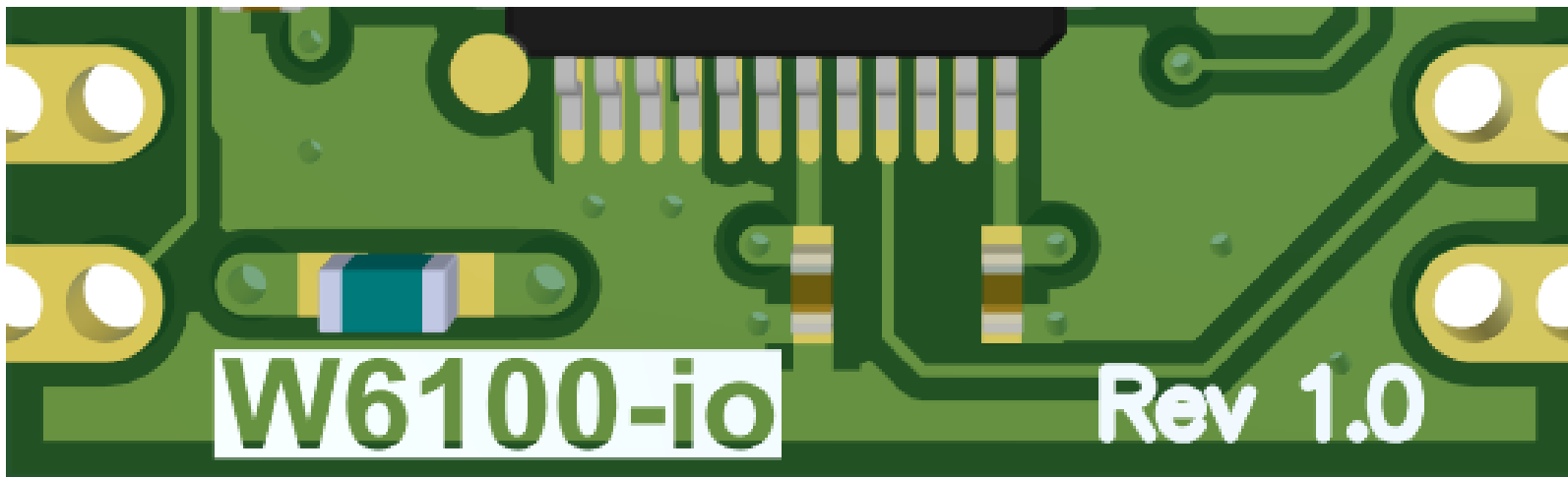

Hardware Specification

W5500-io

- Plugin Network Module.
- Hardware compatible with W5100S-io, W5500-io.
- Usable without H/W design for W6100.
- Fast evaluation for W6100 & MCU in the target board.
- Support high speed SPI interface.
- Support power down mode and Wake-on-LAN function
- Very small form factor : 20mm x 24mm x 2.6mm

Pin Out

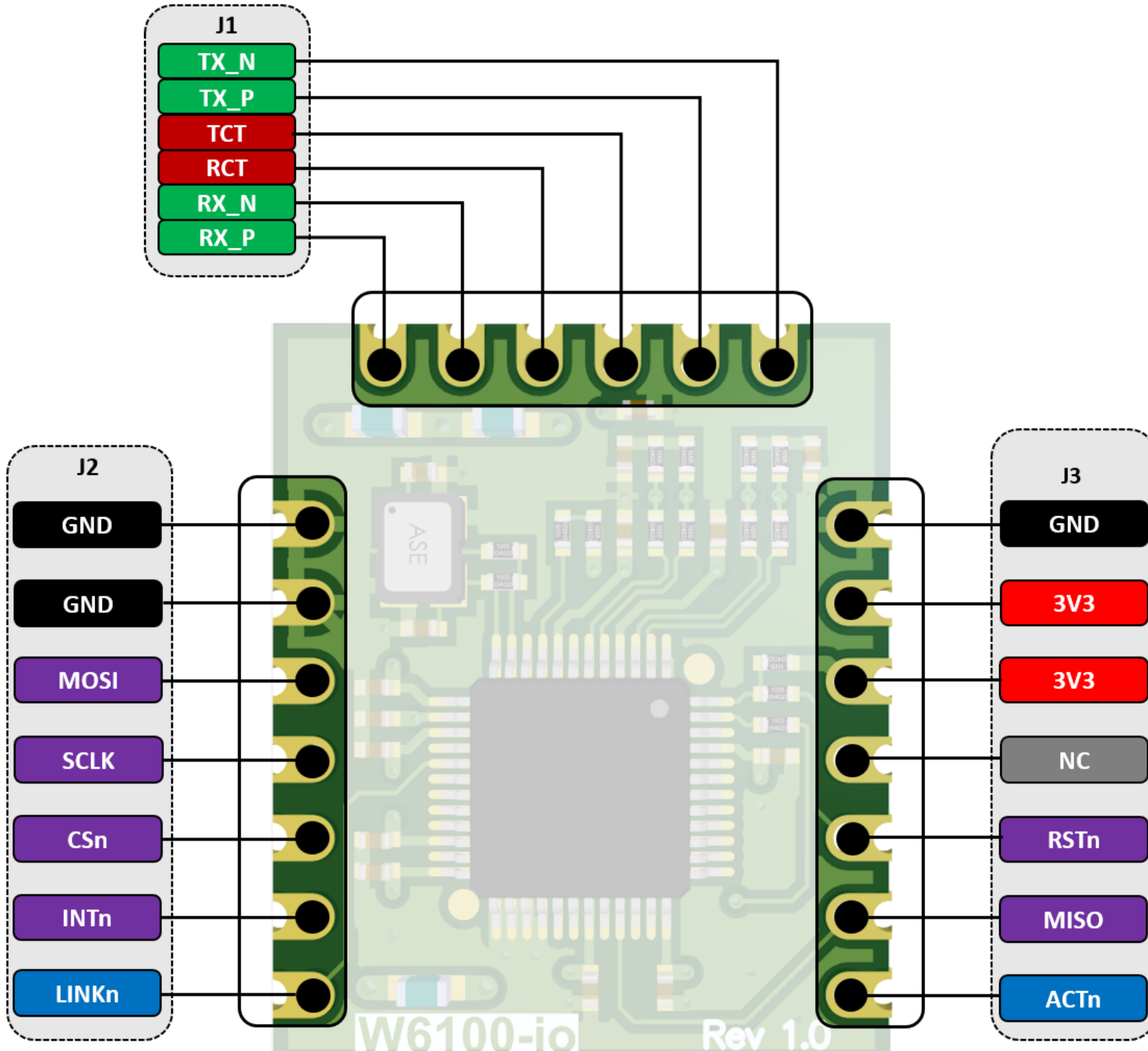

Pin Description

Pin No.		Pin Type	Pin Name	Description
J1	1	I	RX_P	RX_P
⋮	2	I	RX_N	RX_N
⋮	3	P	RCT	RX Center Tap This pin should be connect with external pulse transformer's RCT pin
⋮	4	P	TCT	TX Center Tap This pin should be connect with external pulse transformer's TCT pin
⋮	5	O	TX_P	TX_P
⋮	6	O	TX_N	TX_N

Pin No.		Pin Type	Pin Name	Description
J2	1	P	GND	Ground
⋮	2	P	GND	Ground

Pin No.		Pin Type	Pin Name	Description
⋮	3	I	MOSI	Master Out Slave In This pin is used for SPI MOSI signal pin
⋮	4	I	SCLK	SPI clock input
⋮	5	I	CSn	Chip select input
⋮	6	O	INTn	Interrupt output Low: Interrupt asserted from W6100 High: No interrupt
⋮	7	O	LINK	LINK status output Low : Link High : Un Link

Pin No.		Pin Type	Pin Name	Description
J3	1	P	GND	Ground
⋮	2	P	3.3V	Power : 3.3V power supply
⋮	3	P	3.3V	Power : 3.3V power supply

Pin No.		Pin Type	Pin Name	Description
⋮	4	-	NC	Not Connect
⋮	5	I	RSTn	Reset : Low activity Hold at least 500us after asserted to LOW and keep HIGH until next Reset needed.
⋮	6	O	MISO	SPI Master In Slave Out This pin is used for SPI MISO signal pin
⋮	7	O	ACTn	Active LED Low: Carrier sense from the active PMD High: No carrier sense

Characteristic

DC Characteristic

Symbol	Parameter	Pins	Min	Typ	Max	Unit
VDD	Supply voltage	3.3V	2.97	3.3	3.63	V
VIL	High level input voltage	ALL	2.0		5.5	V

Symbol	Parameter	Pins	Min	Typ	Max	Unit
<i>VIH</i>	Low level input voltage	ALL	-0.3		0.8	V
<i>VOL</i>	Low level output voltage	ALL			0.4	V
<i>VOH</i>	High level output voltage	ALL	2.4			V
<i>LOL</i>	Low level output Current	ALL	8.6	13.9	18.9	mA
<i>LOH</i>	High level output Current	ALL	12.5	26.9	47.1	mA
<i>IDD</i>	Supply Current (Normal operation mode)	3.3V		132		mA
<i>LOH</i>	Supply Current (Power Down mode)	3.3V		13		mA

Power Dissipation

Condition	Min	Typ	Max	Unit
100M Link	-	98	115	mA
10M Link	-	112	265	mA

Condition	Min	Typ	Max	Unit
Un-Link (Auto-negotiation mode)	-	50	199	mA
Power Down mode	-	14	20	mA

SPI Operations

As W6100-io consists of W6100 and others, SPI operation of W6100-io follows one of W6100. For more information about SPI operation of W6100-io, please refer to [W6100 Datasheet](#).

Schematic & Artwork

Module

- Revision 1.0 [W6100-io V100 Schematic\(PDF\)](#)
- Revision 1.0 [W6100-io V100 Schematic\(Altium\)](#)

Reference Schematic

- Revision 1.0 [W6100-io V100 Reference Schematic\(PDF\)](#)

Part list

- Revision 1.0 [W6100-io V100 Part list\(PDF\)](#)
- Revision 1.0 [W6100-io V100 Part list\(Excel\)](#)

Dimension

- W6100-io V100 Dimension
 - 24mm x 20mm x 1.0mm (PCB board size)
 - 24mm x 20mm x 2.6mm (Included part size)

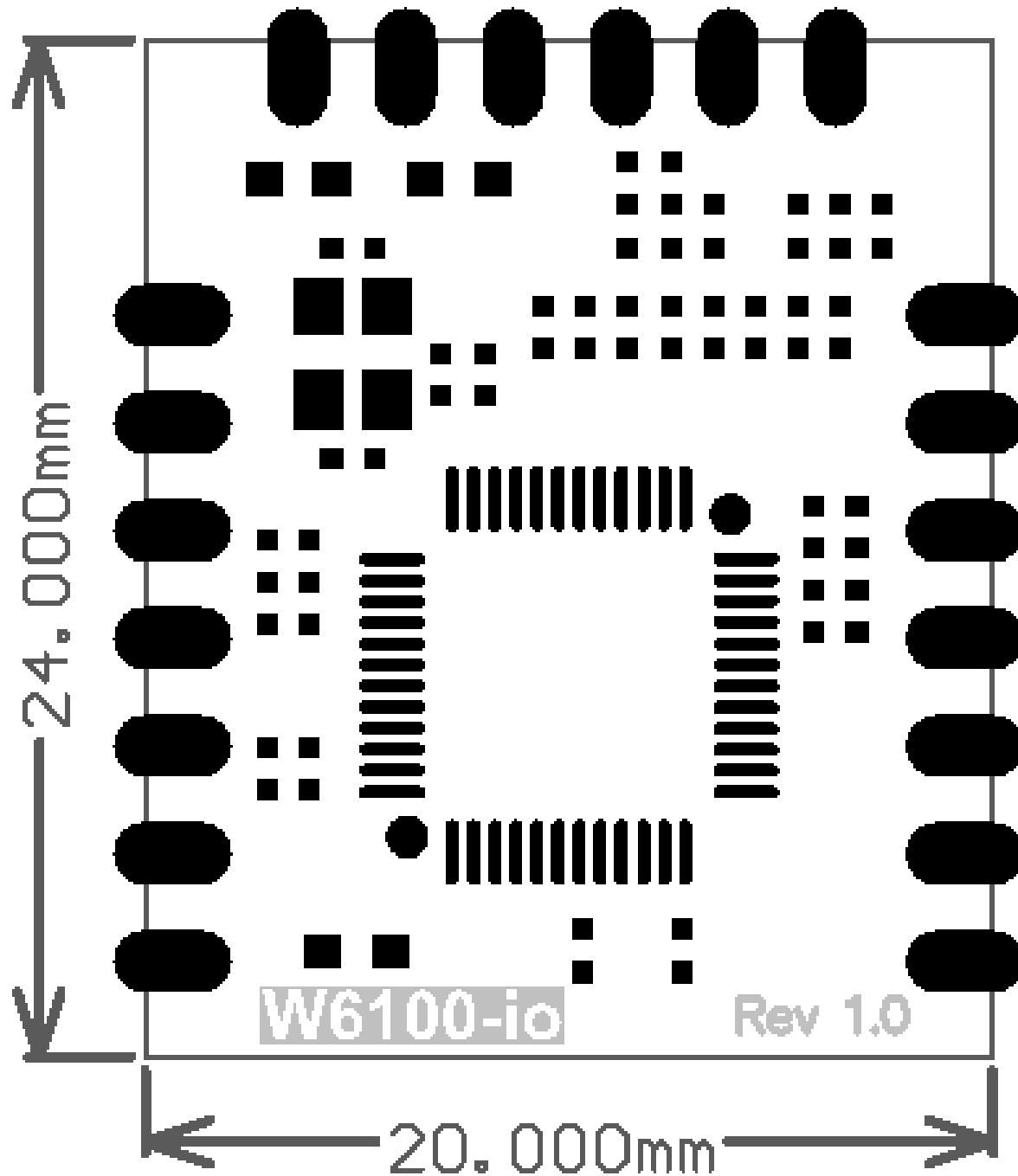

 [Edit this page](#)