

**ebm-papst Mulfingen GmbH & Co. KG**

Bachmühle 2 · D-74673 Mulfingen

Phone +49 7938 81-0

Fax +49 7938 81-110

info1@de.ebmpapst.com

www.ebmpapst.com

Limited partnership · Headquarters Mulfingen

Amtsgericht (court of registration) Stuttgart · HRA 590344

General partner Elektrobau Mulfingen GmbH · Headquarters Mulfingen

Amtsgericht (court of registration) Stuttgart · HRB 590142

**Nominal data**

<b>Type</b>	<b>K3G280-PR04-I2</b>	
<b>Motor</b>	<b>M3G084-DF</b>	
Phase		1~
Nominal voltage	VAC	230
Nominal voltage range	VAC	200 .. 277
Frequency	Hz	50/60
Method of obtaining data		ml
Speed	min <sup>-1</sup>	3000
Power consumption	W	750
Current draw	A	3.3
Min. ambient temperature	°C	-25
Max. ambient temperature	°C	45

ml = Max. load · me = Max. efficiency · fa = Free air · cs = Customer specification · ce = Customer equipment  
Subject to change

**Data according to ErP Directive**

		Actual	Req. 2015			
01 Overall efficiency $\eta_{es}$	%	67.6	50	09 Power consumption $P_{ed}$	kW	0.72
02 Measurement category		A		09 Air flow $q_v$	m <sup>3</sup> /h	2400
03 Efficiency category		Static		09 Pressure increase $p_{fs}$	Pa	665
04 Efficiency grade N		79.6	62	10 Speed n	min <sup>-1</sup>	2990
05 Variable speed drive		Yes		11 Specific ratio*		1.01

Data obtained at optimum efficiency level.

The ErP data is determined using a motor-impeller combination in a standardized measurement setup.

\* Specific ratio =  $1 + p_{fs} / 100\,000\text{ Pa}$

LU-173985



## Technical description

<b>Weight</b>	9.1 kg
<b>Fan size</b>	280 mm
<b>Rotor surface</b>	Painted black
<b>Electronics housing material</b>	Die-cast aluminum
<b>Impeller material</b>	PP plastic
<b>Support plate material</b>	Sheet steel, galvanized
<b>Support bracket material</b>	Steel, painted black
<b>Inlet nozzle material</b>	Sheet steel, galvanized
<b>Number of blades</b>	6
<b>Direction of rotation</b>	Clockwise, viewed toward rotor
<b>Degree of protection</b>	IP55
<b>Insulation class</b>	"F"
<b>Moisture (F) / Environmental (H) protection class</b>	H1
<b>Max. permitted ambient temp. for motor (transport/storage)</b>	+ 80 °C
<b>Min. permitted ambient temp. for motor (transport/storage)</b>	- 40 °C
<b>Installation position</b>	Shaft horizontal or rotor on bottom; rotor on top on request
<b>Condensation drainage holes</b>	On rotor side
<b>Mode</b>	S1
<b>Motor storage</b>	Ball bearing
<b>Technical features</b>	<ul style="list-style-type: none"> <li>- Output 10 VDC, max. 10 mA</li> <li>- Operation and alarm display</li> <li>- Alarm relay</li> <li>- Integrated PID controller</li> <li>- Power limiter</li> <li>- Motor current limitation</li> <li>- PFC, active</li> <li>- RS-485 MODBUS-RTU</li> <li>- Soft start</li> <li>- Control input 0-10 VDC / PWM</li> <li>- Control interface with SELV potential safely disconnected from the mains</li> <li>- Thermal overload protection for electronics/motor</li> <li>- Line undervoltage / phase failure detection</li> </ul>
<b>EMC immunity to interference</b>	According to EN 61000-6-2 (industrial environment)
<b>EMC circuit feedback</b>	According to EN 61000-3-2/3
<b>EMC interference emission</b>	According to EN 61000-6-3 (household environment)
<b>Touch current according to IEC 60990 (measuring circuit Fig. 4, TN system)</b>	<= 3.5 mA
<b>Motor protection</b>	Thermal overload protector (TOP) internally connected
<b>With cable</b>	Variable
<b>Protection class</b>	I (with customer connection of protective earth)
<b>Conformity with standards</b>	EN 61800-5-1; CE
<b>Approval</b>	C22.2 No.77 + CAN/CSA-E60730-1; UL 1004-7 + 60730

## Product drawing

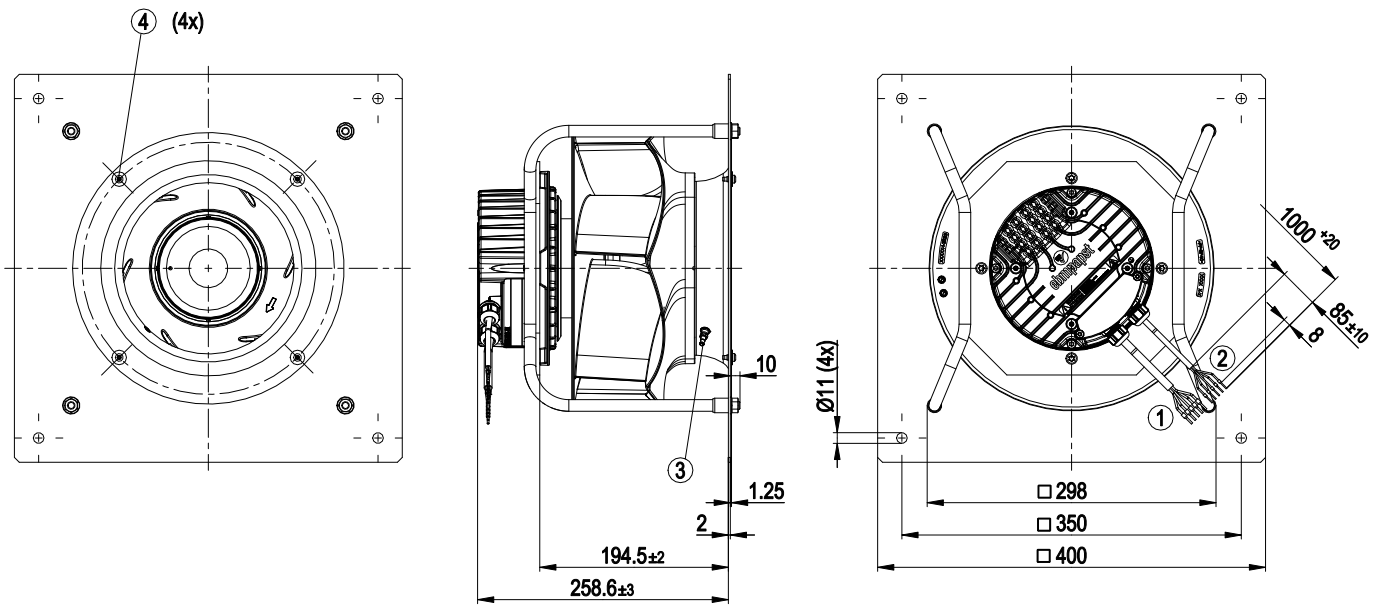

1	Cable PVC AWG18, 5x crimped ferrules
2	Cable PVC AWG22, 5x crimped ferrules
3	inlet ring 28004-2-4013 with pressure tap (k-factor: 77)
4	Attachment for inlet ring and FlowGrid

## Connection diagram

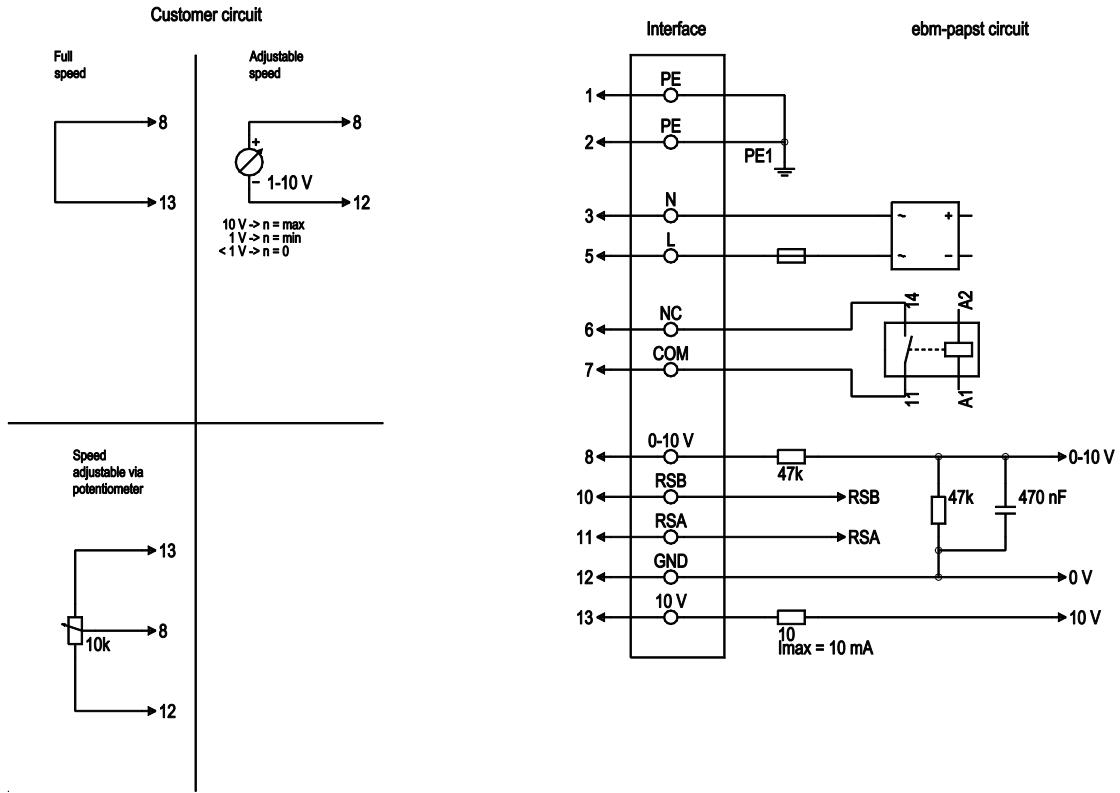

No.	Conn.	Designation	Color	Function/assignment
1	1, 2	PE	green/yellow	Protective earth
1	3	N	blue	Power supply, neutral conductor, 50/60 Hz
1	5	L	black	Power supply, phase, 50/60 Hz
1	6	NC	white 1	Status relay, floating status contact; break for failure, contact rating 250 VAC / 2A (AC1) / min. 10 mA, basic insulation on supply side and reinforced insulation on control interface side
1	7	COM	white 2	Status relay, floating status contact; common connection, contact rating 250 VAC / 2A (AC1) / min. 10 mA, basic insulation on supply side and reinforced insulation on control interface side
2	8	0-10V	yellow	Analog input (set value); 0-10 V; R <sub>i</sub> = 100 kΩ; adjustable curve
2	10	RSB	brown	RS485 interface for MODBUS, RSB
2	11	RSA	white	RS485 interface for MODBUS, RSA
2	12	GND	blue	Reference ground for control interface, SELV
2	13	+10V	red	Fixed voltage output 10 VDC, +10 V ±3%; max. 10 mA; short-circuit-proof; power supply for external devices (e.g. pot)

## Curves: Air performance 50 Hz

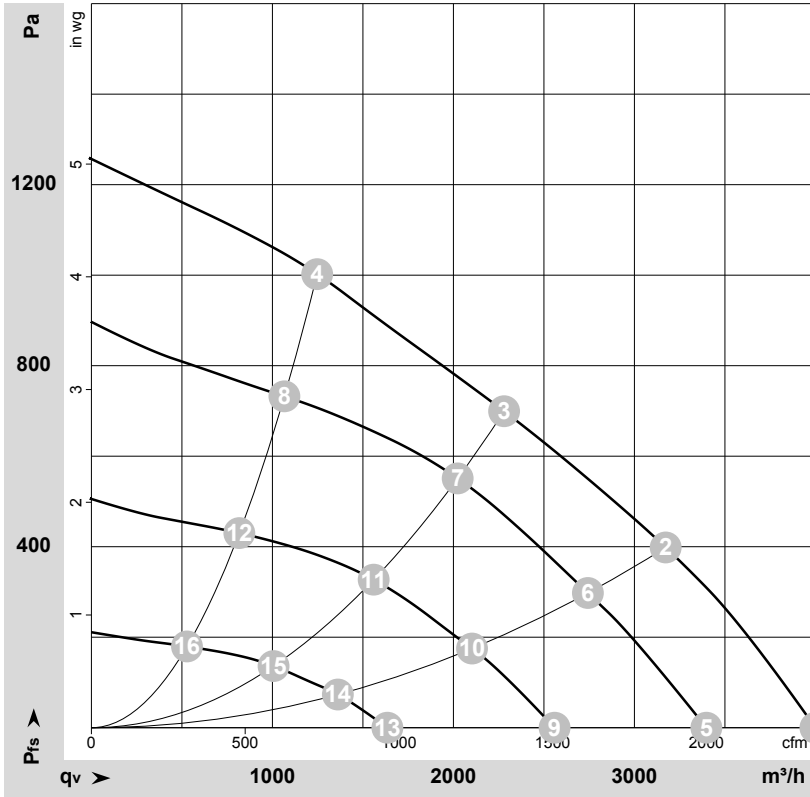

$\rho = 1,15 \text{ kg/m}^3 \pm 2\%$

Measurement: LU-173985

Air performance measured according to ISO 5801 installation category A. For detailed information on the measurement setup, contact ebmpapst. Intake sound level: Sound power level according to ISO 13347 / sound pressure level measured at 1 m distance from fan axis. The values given are valid under the specified measuring conditions and may vary due to conditions of installation. For deviations from the standard configuration, the parameters have to be checked on the installed unit.

## Measured values

	U	f	n	P <sub>ed</sub>	I	LpA <sub>in</sub>	LwA <sub>in</sub>	qv	p <sub>fs</sub>
	V	Hz	min <sup>-1</sup>	W	A	dB(A)	dB(A)	m <sup>3</sup> /h	Pa
1	230	50	3260	642	2.81	80	87	4000	0
2	230	50	3115	729	3.18	74	82	3175	400
3	230	50	3000	750	3.30	69	77	2280	700
4	230	50	3180	722	3.15	75	82	1245	1000
5	230	50	2780	404	1.79	75	83	3395	0
6	230	50	2695	470	2.07	69	77	2745	298
7	230	50	2660	509	2.24	65	73	2025	552
8	230	50	2710	456	2.01	70	77	1065	732
9	230	50	2100	186	0.85	68	75	2560	0
10	230	50	2070	227	1.02	62	70	2105	175
11	230	50	2050	243	1.09	58	65	1560	328
12	230	50	2080	213	0.96	61	69	815	430
13	230	50	1355	63	0.37	58	66	1635	0
14	230	50	1335	75	0.41	53	61	1360	75
15	230	50	1330	79	0.43	49	56	1005	136
16	230	50	1345	71	0.40	53	58	530	180

U = Power supply · f = Frequency · n = Speed · P<sub>ed</sub> = Power consumption · I = Current draw · LpA<sub>in</sub> = Sound pressure level intake side · LwA<sub>in</sub> = Sound power level intake side  
 qv = Air flow · p<sub>fs</sub> = Pressure increase

