

Frontplattenausschnitt (Rueckseite)
Panel cut out (rear side)

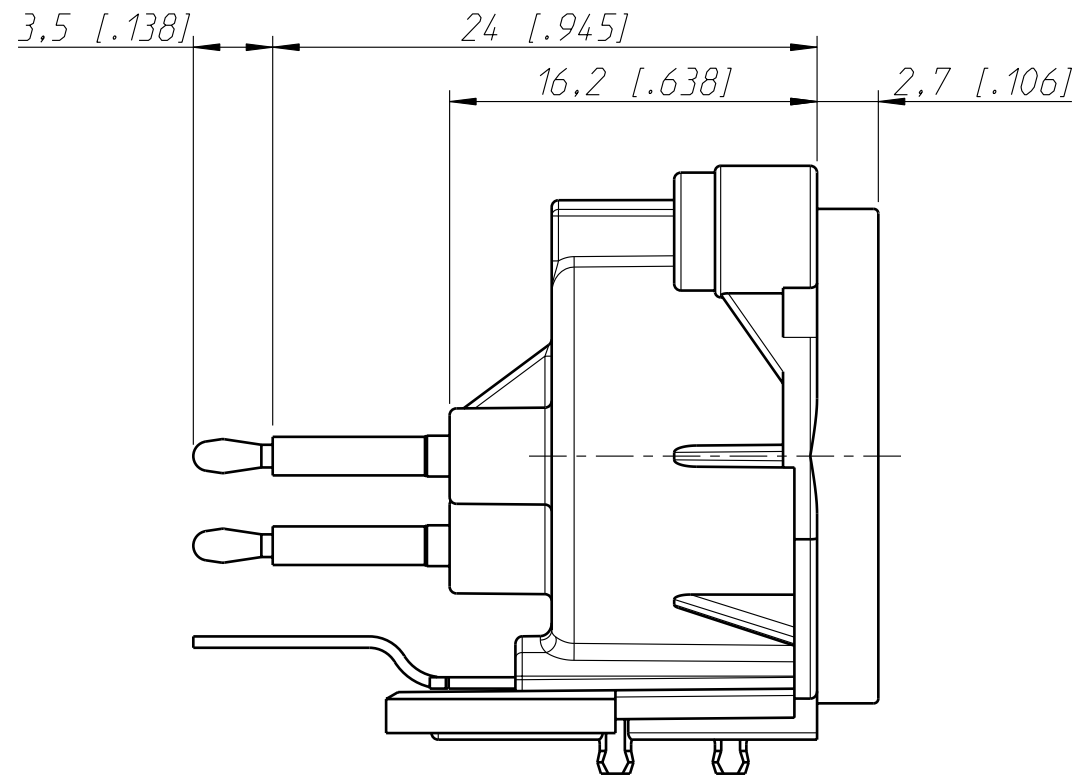

Print Bohrplan (Bestueckungsseite)
PCB-Layout (component side)

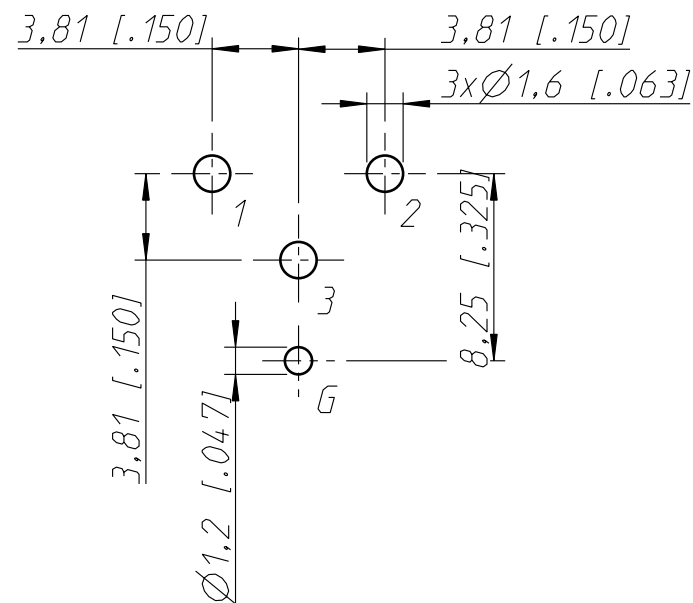
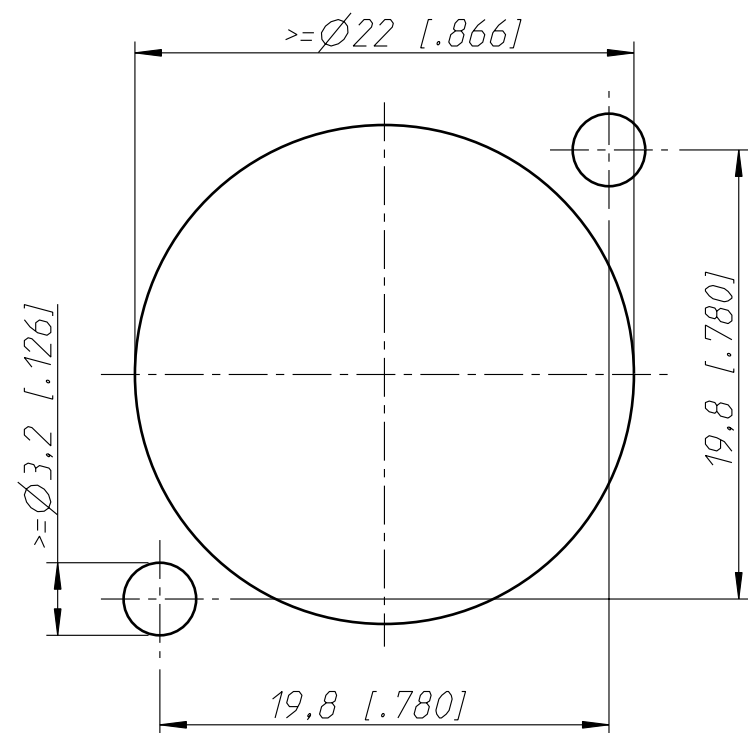
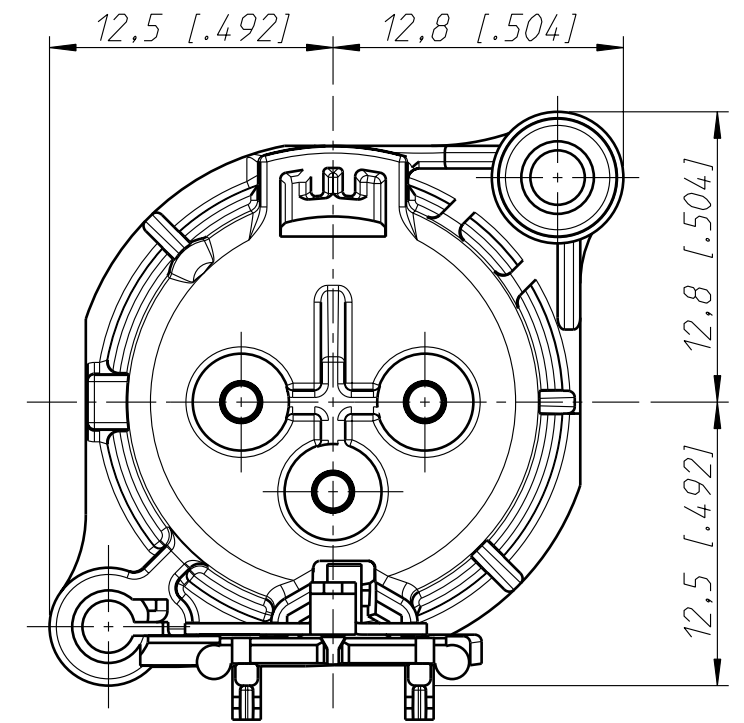

Housing material: UL94 V-0

Allgemeintoleranzen ISO 2768-m	Werkstoff	Massstab:	Datum	Name
Zeichnung urheberrechtlich geschuetzt (DIN 34) (C)	-	3:1 (A3)	Gezeichnet	17.07.03 Ender
			Freigegeben	
Benennung NC3MAV-0 NC3MAV-0 NEUTRIK AG FL-9494 SCHAAN			Geaendert	13.01.10 Mijatovic
			Aend.-Nr.	-
			Ersatz fuer:	Blatt 1 von 1 Bl.
			Zeichn. Nr.	ST-NC3MAV-0