

WiMOD – iU891A-XL

Datasheet Version 1.1

Document ID: 4000/40140/0192

IMST GmbH

Carl-Friedrich-Gauß-Str. 2-4

47475 KAMP-LINTFORT

GERMANY



Document Information

| | |
|-------------|-----------------------|
| File name | iU891A_Datasheet.docx |
| Created | 2024-03-04 |
| Total pages | 15 |

Revision History

| Version | Note |
|---------|-----------------------------|
| 1.0 | Released |
| 1.1 | Antennas changed, chapter 4 |
| | |

General user information

The aim of this document is to give a detailed product description including interfaces, features and performance of the USB stick iU891A-XL.

This document has to be treated confidentially. The content must not be published, duplicated or passed to third parties without our express permission.

Observe the safety instructions and warnings in this documentation.

Keep this document for future reference.



Disposal of the device

Do not dispose this product at the end of its life in the household waste, but in the designated places for recycling old electrical equipment. Beware the environment.

Table of Contents

| | |
|---|----|
| 1. INTRODUCTION | 3 |
| 1.1 Key Features | 3 |
| 1.2 Applications | 3 |
| 2. USB OVERVIEW | 4 |
| 3. ELECTRICAL CHARACTERISTICS | 5 |
| 3.1 Absolute Maximum Ratings | 5 |
| 3.2 Global Electrical Characteristics | 6 |
| 4. USB PACKAGE | 7 |
| 5. INTERFACE CHARACTERISTICS | 9 |
| 5.1 Cypress Driver | 9 |
| 5.2 Radio Module Reset Interface | 9 |
| 5.3 Radio Module Boot Loading Interface | 9 |
| 6. ORDERING INFORMATION | 10 |
| 7. APPENDIX | 11 |
| 7.1 List of Figures | 11 |
| 7.2 List of Tables | 11 |
| 7.3 References | 11 |
| 8. RESTRICTIONS AND LIMITATIONS | 12 |
| 8.1 Hardware Restrictions and Limitations | 12 |
| 8.2 Software Restrictions and Limitations | 12 |
| 8.3 Compliancy Restrictions and Limitations | 12 |
| 8.4 Disclaimer | 13 |
| 9. CONTACT INFORMATION | 14 |

1. Introduction

iU891A-XL is a low cost and high output power USB-adapter supporting LoRa®, LoRaWAN® and wireless M-Bus. It is based on the radio module iM891A-XL, representing the great performance of the radio module at the SMA connector.

With an integrated +22 dBm power amplifier and a sensitivity of -149 dBm, a sensational link budget of approx. 170 dB can be reached. With this, ranges well beyond 15 km can be achieved. For flexible antenna usage, the iU891A-XL provides an SMA connector to be able to connect antennas individually optimized to the needs of the scenarios of operation.

The iU891A-XL supports the wireless M-Bus modes S, C, T and C/T with packet formats A and B as well as the OMS security modes 5 and 7. In addition, the sophisticated IMST ProLink protocol stack is also available. It combines compliant LoRaWAN functions and proprietary LoRa functions within one stack. This makes the iU891A-XL an ideal solution for numerous applications such as meter reading, wireless M-Bus Gateway expansion, LPWAN and IoT sensors, as well as home-, building- and industrial-automation.



Figure 1-1: Picture of iU891A-XL (displayed without antenna here)

1.1 Key Features

- iM891A-XL Radio Module
- RED certified for usage of ProLink or wireless M-Bus firmware

1.2 Applications

- Automated Meter Reading
- Wireless Networks
- Home-, Building-, Industrial automation
- Remote Control
- Wireless Sensors
- Telemetry
- Wireless Alarm and Security Systems
- ...

Please visit our web site www.wireless-solutions.de for more information as well as the latest documents and software versions.

2. USB Overview

The iU891A-XL is an ultra-long range, high-performance, pre-certified USB-adapter for wireless communication. It operates in the license free 868 MHz SRD frequency band and includes all necessary passive components for wireless communication as depicted in the following figure.

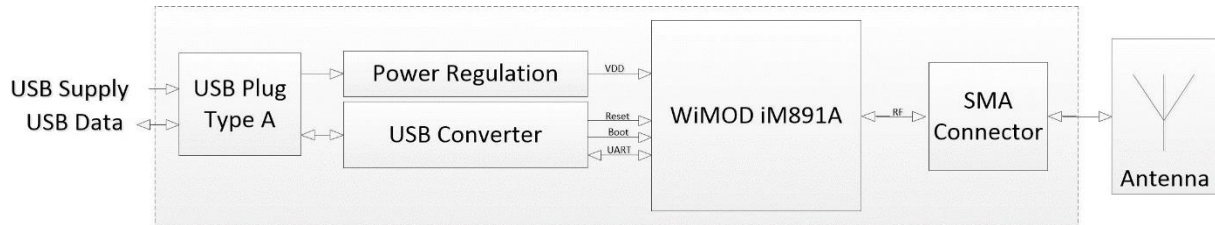

Figure 2-1: Picture of iU891A-XL

Note: iU891A-XL is designed to be used with the designated antenna. Operation with different antennas or without an antenna can result in a damage of the device!

3. Electrical Characteristics

In the following different electrical characteristics of the iU891A-XL are listed. Furthermore, details and other parameter ranges are available on request.

Note: National laws and regulations, as well as their interpretation can vary with the country. In case of uncertainty, it is recommended to contact either IMST's accredited Test Center or to consult the local authorities of the relevant countries.

3.1 Absolute Maximum Ratings

Note: Stress exceeding of one or more of the limiting values listed under "Absolute Maximum Ratings" may cause permanent damage to the radio module.

| Parameter | Condition | Min | Typ. | Max | Unit |
|---|-----------|-----|------|-----|------|
| Supply Voltage (VDD) | | | | 6.0 | V |
| Current Consumption | | | | 200 | mA |
| Storage Temperature | | -40 | - | +85 | °C |
| Operating Temperature | | -40 | - | +85 | °C |
| RF Input Power | | | | +0 | dBm |
| ESD (Human Body Model) | | | 2000 | | V |
| ESD (Charge Device Model) | | | 500 | | V |
| | | | | | |
| Notes: 1) Unless otherwise noted, all voltages are with respect to GND | | | | | |

Table 3-1: Absolute Maximum Ratings

Note: To avoid too large input power level, the distance to other transmitting devices shall be at least 1 m

3.2 Global Electrical Characteristics

T = 25°C, VDD = 5.0 V (typ.), performance at SMA connector, if nothing else stated

| Parameter | Condition | Min | Typ. | Max | Unit |
|----------------------|---|------|------|------|------|
| Supply Voltage (VDD) | | 4.35 | 5.0 | 5.25 | V |
| RF Frequency Range | | 863 | | 870 | MHz |
| RF Output Power | Level Setting 14 | | 12.5 | | dBm |
| | Level Setting 22 | | 20.5 | | dBm |
| RF Sensitivity | DR 7.8 kHz, SF7 | | -137 | | dBm |
| | DR 7.8 kHz, SF12 | | -149 | | dBm |
| | DR 125 kHz, SF7 | | -125 | | dBm |
| | DR 125 kHz, SF12 | | -138 | | dBm |
| | S1-Mode 868.3 MHz, DR 32.768 kbps, Frequency-Deviation: ±50 kHz | | -106 | | dBm |
| | T1-Mode 868.95 MHz, DR 100 kbps, Frequency- Deviation: ±50 kHz | | -106 | | dBm |
| | C1-Mode 868.95 MHz, DR 100 kbps, Frequency- Deviation: ±45 kHz | | -106 | | dBm |

4. USB Package

The iU891A-XL is characterized by the following dimensions¹:

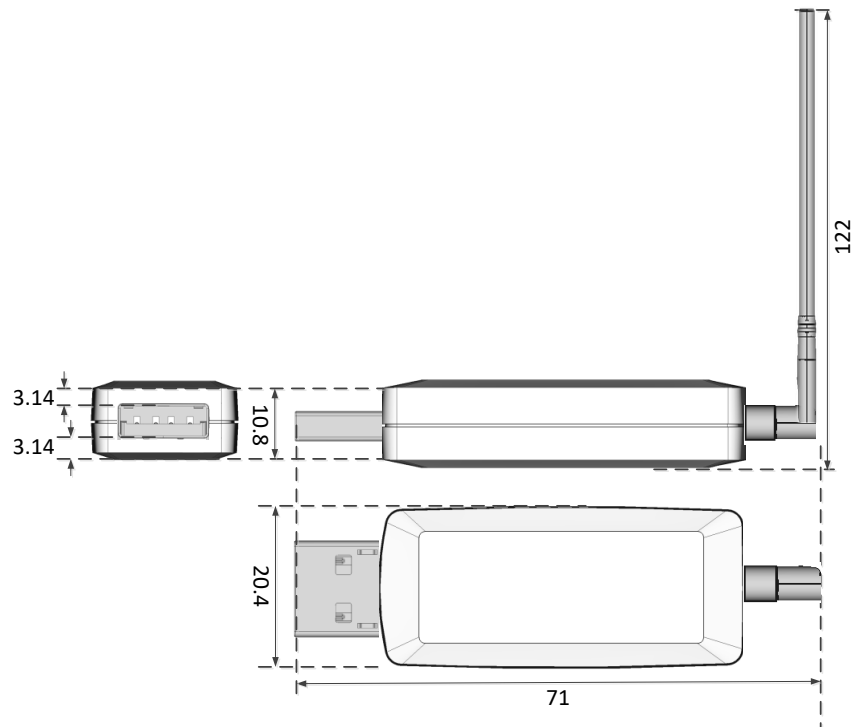

Figure 4-1: Articulated joint dipole **Antenna_A** 0° and 90° without iU891A-XL

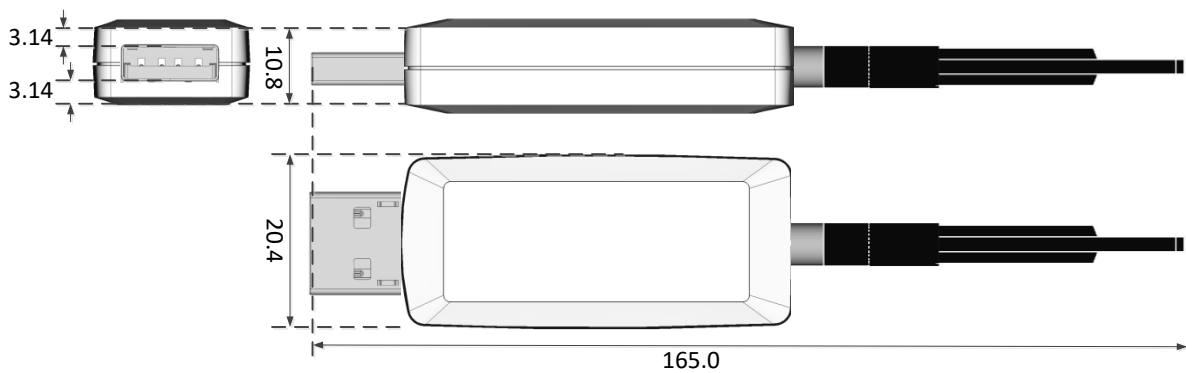

Figure 4-2: Dimensions of iU891A-XL with articulated joint dipole **Antenna_B** 0°

¹ Dimensions not to scale

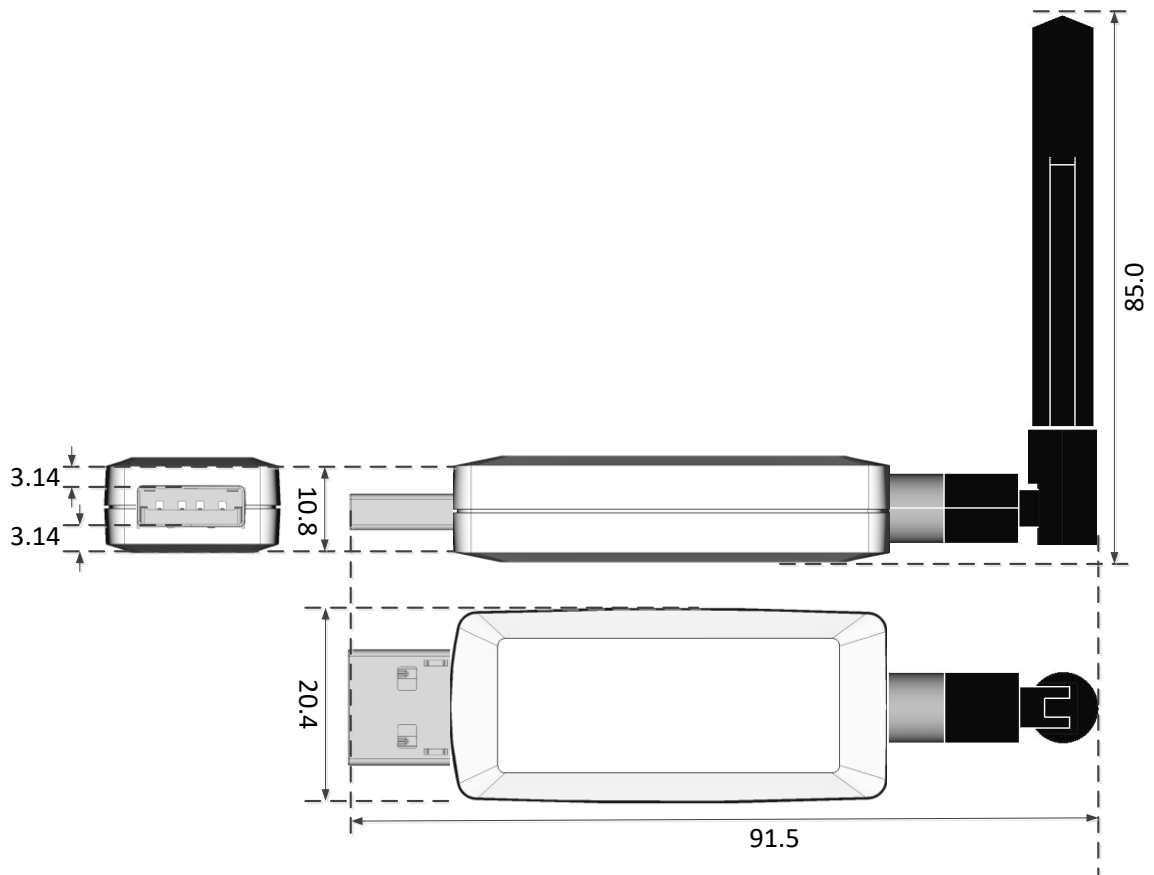

Figure 4-3: Dimensions of iU891A-XL with articulated joint dipole **Antenna_B** 90°

5. Interface Characteristics

The iU891A-XL provides several interfaces through the USB-converter chip to get access to the radio module iM891A-XL, which is part of the iU891A-XL. It is highly recommended, to implement all interfaces at the host device to guarantee a reliable usage of the iU891A-XL. In detail, there is a UART interface, a reset signal and a boot loading signal.

5.1 Cypress Driver

The USB-converter of the iU891A-XL is an Infineon CY7C65213A-32LTXIT. Please refer to <https://www.infineon.com> for detailed information of the chip and required drivers for the host system.

5.2 Radio Module Reset Interface

The reset signal for the radio module iM891A-XL is connected to the GPIO2 signal of the USB-converter. This GPIO can be used, to execute a reset of the radio module. To perform a reset of the radio module, GPIO2 needs to be set to low-level for at least 100 ms. Afterwards, the pin needs to be released or pulled to high-level. It is recommended to implement this functionality on the host system.

5.3 Radio Module Boot Loading Interface

The firmware of the radio module iM891A-XL is capable of being updated via the USB-converter interfaces. First, the boot loading signal needs to be applied to high-level via the USB-converter GPIO3. Afterwards, a reset needs to be executed as described in chapter 5.2. Now, the radio module is ready in boot loading mode and the firmware can be transferred using the USB-converter via UART interface (USB-converter virtual comport interface). Please refer STM AN2606 and AN3155 for detailed information. It is recommended to implement this functionality on the host system.

6. Ordering Information

| Ordering Part Number | Description | Distributor |
|----------------------|--|--|
| 404926 | iU891A-XL with wireless M-Bus firmware | sales@imst.de |
| 404927 | iU891A-XL with LoRaWAN firmware | |
| 404829 | Antenna_A: Articulated joint dipole antenna (142 x 10mm) recommended | |
| 404825 | Antenna_B: Articulated joint dipole antenna (105 x 11mm) | |

Table 6-1: Ordering Information

7. Appendix

7.1 List of Figures

| | |
|--|---|
| Figure 1-1: Picture of iU891A-XL (displayed without antenna here) | 3 |
| Figure 2-1: Picture of iU891A-XL | 4 |
| Figure 4-1: Articulated joint dipole Antenna_A 0° and 90° without iU891A-XL | 7 |
| Figure 4-2: Dimensions of iU891A-XL with articulated joint dipole Antenna_B 0° | 7 |
| Figure 4-3: Dimensions of iU891A-XL with articulated joint dipole Antenna_B 90° | 8 |

7.2 List of Tables

| | |
|---|----|
| Table 3-1: Absolute Maximum Ratings | 5 |
| Table 6-1: Ordering Information | 10 |

7.3 References

- [1] [WiMOD iM891A-XL Datasheet, https://wireless-solutions.de/](https://wireless-solutions.de/)

8. Restrictions and Limitations

8.1 Hardware Restrictions and Limitations

The characteristic values given by the present document are typically obtained by measurements based on evaluation kits of the entitled device. Using other carrier boards or connected equipment might lead to different characteristics. Subject to given measurement results the characteristic values might show the best performance of the entitled device, independent from any compliancy restriction of final operation purposes. All given values are subject to changes without prior notice.

8.2 Software Restrictions and Limitations

The present document is a datasheet of the entitled device which intentional use is to provide information about basic characteristics related to the device hardware. Typically, all described characteristic values require software for obtaining them accordingly. All features of the available software are subject to changes without claim to be complete at any time. Characteristically values might also be provided based on datasheets of the appropriate key components unless there are test results available based on the available software. For more information regarding current supported features of the available software refer to www.wireless-solutions.de.

8.3 Compliancy Restrictions and Limitations

The entitled device has been designed to comply with the standards namely given in the present document. The intentional operation shall be in so called ISM bands, which can be used free of charge within the European Union and typically licences free all over the world. Nevertheless, restrictions such as maximum allowed radiated RF power or duty cycle may apply which might result in a reduction of these parameters accordingly.

In addition, the use of radio frequencies might be limited by national regulations which requirements also need to be met.

In case the entitled device will be embedded into other products (referred as "final products"), the manufacturer for this final product is responsible to declare the conformity to required standards accordingly. A proof of conformity for the entitled device is available from IMST GmbH on request. Beside the entitled device the conformity also considers software as well as supporting hardware characteristics which might also have an impact accordingly.

The applicable regulation requirements are subject to change. IMST GmbH does not take any responsibility for the correctness and accuracy of the aforementioned information. National laws and regulations, as well as their interpretation can vary with the country. In case of uncertainty, it is recommended to contact either IMST's accredited Test Center or to consult the local authorities of the relevant countries.

8.4 Disclaimer

IMST GmbH points out that all information in this document is given on an “as is” basis. No guarantee, neither explicit nor implicit is given for the correctness at the time of publication. IMST GmbH reserves all rights to make corrections, modifications, enhancements, and other changes to its products and services at any time and to discontinue any product or service without prior notice. It is recommended for customers to refer to the latest relevant information before placing orders and to verify that such information is current and complete. All products are sold and delivered subject to “General Terms and Conditions” of IMST GmbH, supplied at the time of order acknowledgment. IMST GmbH assumes no liability for the use of its products and does not grant any licenses for its patent rights or for any other of its intellectual property rights or third-party rights. It is the customer’s duty to bear responsibility for compliance of systems or units in which products from IMST GmbH are integrated with applicable legal regulations. Customers should provide adequate design and operating safeguards to minimize the risks associated with customer products and applications. The products are not approved for use in life supporting systems or other systems whose malfunction could result in personal injury to the user. Customers using the products within such applications do so at their own risk.

Any reproduction of information in datasheets of IMST GmbH is permissible only if reproduction is without alteration and is accompanied by all given associated warranties, conditions, limitations, and notices. Any resale of IMST GmbH products or services with statements different from or beyond the parameters stated by IMST GmbH for that product/solution or service is not allowed and voids all express and any implied warranties. The limitations on liability in favor of IMST GmbH shall also affect its employees, executive personnel and bodies in the same way. IMST GmbH is not responsible or liable for any such wrong statements.

Copyright © 2024, IMST GmbH

9. Contact Information

IMST GmbH

Carl-Friedrich-Gauß-Str. 2-4
47475 Kamp-Lintfort
Germany

T +49 2842 981 0

F +49 2842 981 299

E sales@imst.de

I www.wireless-solutions.de

