

**DISPLAY Elektronik GmbH**

# **DATA SHEET**

***Control Button***

**DE CB-480480B VMH-PW-N**

**Product Specification**

**Ver.: 5**

**30.05.2023**

**Revision History**

<b>Revision</b>	<b>Date</b>	<b>Originator</b>	<b>Detail</b>	<b>Remarks</b>
0	08.04.2022	ZFY	Initial Release	
1	23.08.2022	LQ	Modify Basic Parameters	P4
			Modify Outline Drawing(B)	P5
			Modify Pins and Module Parameter	P6
			Modify Optical Characteristic	P7
			Add OPERATING GUIDE	P12-19
2	08.01.2023	LQ	Modify Basic Parameters	P4
			Modify Reliability	P11
3	28.04.2023	LQ	Modify Outline Drawing(C)	P6
4	24.05.2023	LQ	Modify Basic Parameters	P4
			Modify Basic Structure	P4
			Modify Outline Drawing(D)	P5
			Modify Positioning Points and Positions	P7
			Modify Movement Amount of Pressing the Rotating Button	P11
5	30.05.2023	LQ	Modify Outline Drawing(E)	P5

**Table of Contents**

No	Item	Page
1	General Description .....	4
2	Basic Parameters .....	4
3.	Mechanical Characteristics.....	4
3.1.	Appearance picture.....	4
3.2	Basic Structure .....	4
3.3	Outline Drawing .....	5
4.	Interface Pins Definition .....	6
5.	Module Parameter .....	6
6.	Optical Characteristics .....	7
7.	Reliability .....	11
8.	Product Packaging Information .....	13
9.	Operation Process.....	14
9.1	Operation Flow Chart .....	14
9.2	Detailed Description of Operation .....	15
10.	Annular LED Status Indicator .....	15
11.	Communication Protocol .....	16
11.1	Communication Protocol Format.....	16
11.2	Communication Instruction Description.....	16
11.3	Check Bit Description .....	18
12.	Secondary Development Description .....	20
12.1	Preparation of Software Tools and Picture Materials .....	20
12.2	Image Processing .....	21
13.3	Data Download .....	22
	Appendix 1 application case: coffee machine controller process .....	23

## 1 General Description

DE CB-480480B VMH-PW-N series module is a module that perfectly combines the display screen, encoder, touch

button and status LED into a rotating button display. The unique innovative structure and exquisite manufacturing process of the module make it have excellent reliability and excellent control experience.

It is applicable to the demand of rotating button control in many industrial applications of electronic products

## 2 Basic Parameters

1. 2.47 inch circular display 480\*480 TFT/UART Interface
2. Annular status LED indicator
3. EC4301-AX-11.2/6.2-20P20 encoder
4. Integral push button
5. FPC standard 0.5mm-6P interface
6. Three point standard screw installation

## 3. Mechanical Characteristics

### 3.1. Appearance picture



### 3.2 Basic Structure

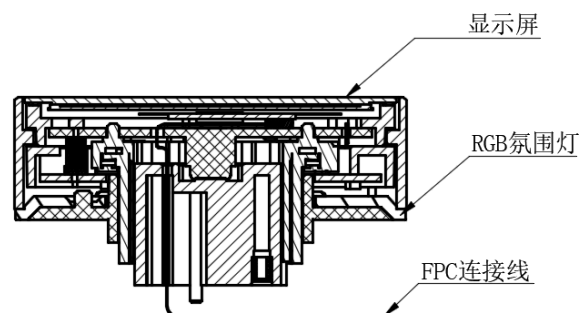

3.3 Outline Drawing

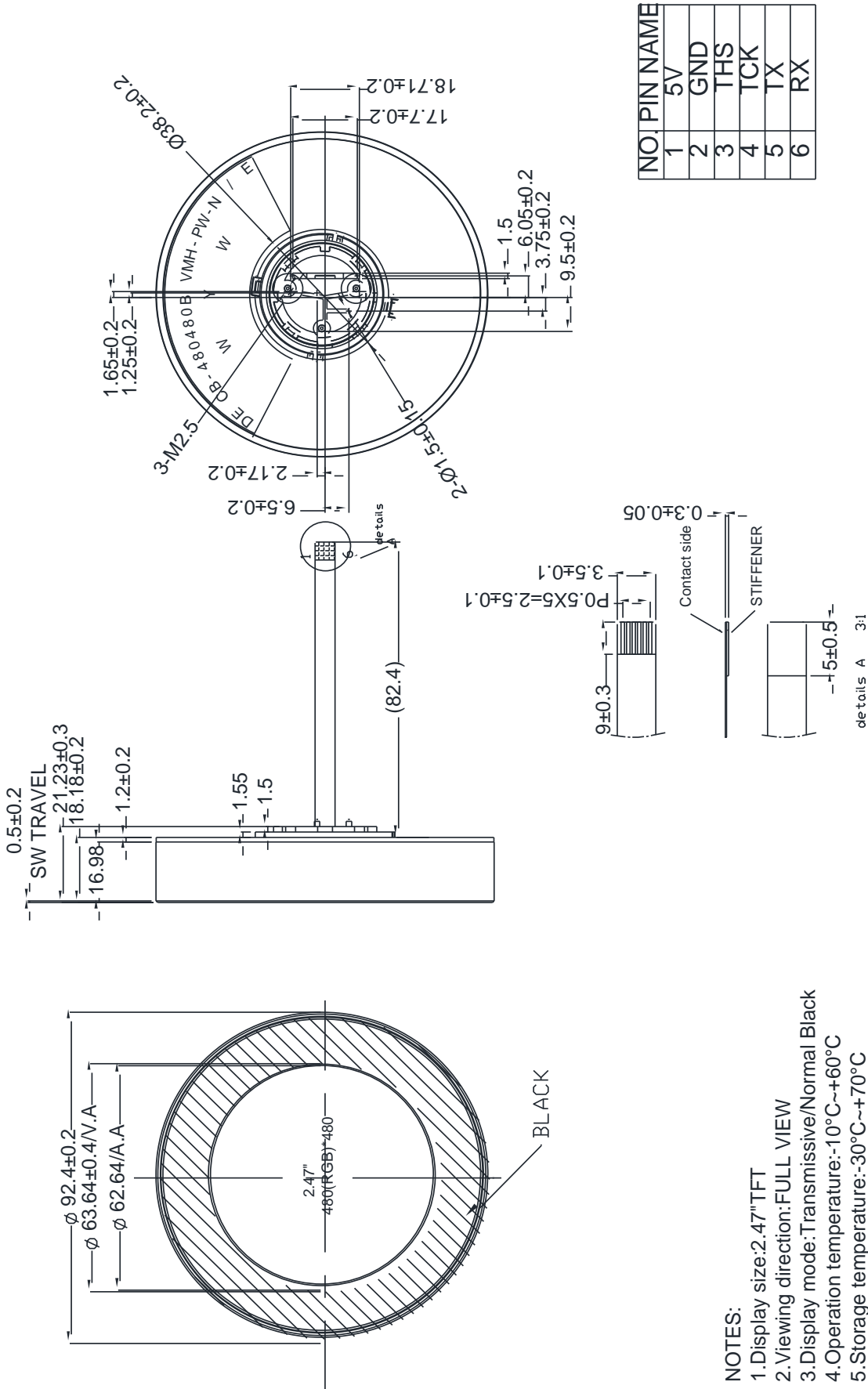

- NOTES:
1. Display size: 2.47" TFT
  2. Viewing direction: FULL VIEW
  3. Display mode: Transmissive/Normal Black
  4. Operation temperature:  $-10^{\circ}\text{C} \sim +60^{\circ}\text{C}$
  5. Storage temperature:  $-30^{\circ}\text{C} \sim +70^{\circ}\text{C}$
  6. Brightness: 290 (TYP) cd/m<sup>2</sup>
  7. ROHS must be complied
  8. The dimension with mark brackets "()" just for reference
- \* Unspecification tolerance are  $\pm 0.3\text{mm}$

details A  
4:1

**4. Interface Pins Definition**

PIN	Symbol	Definition	Remarks
1	5V	Power supply	
2	GND	Power Ground	
3	THS	Software Burning pin	3.3V
4	TCK	Software Burning pin	3.3V
5	TX	Data Output	3.3V
6	RX	Data Input	3.3V

**5. Module Parameter**

Features	Details	Remark
Module Size	Φ92.4(W/H) x 18.18(T) mm	
Viewing Area	Φ63.64(W/H) mm	
Active Area	Φ62.64(W/H) mm	
Display Size	2.47"	
View Direction	ALL	
Display mode	Transmissive / Normal black	
Color	262K	
Resolution	480 (W) *480 (H)	
Luminance	290cd/m <sup>2</sup>	
Operating Temperature	-10°C~60°C/96H	
Storage Temperature	-30°C~70°C/96H	
Operating Voltage	4.5V~7V, typ : 5V	
Current Consumption	200mA~350mA , typ: (280)mA	
Weight	(115)g	

**6. Optical Characteristics**

Ta=25°C

Parameter	Symbol	Condition	Min.	Typ.	Max.	Unit	Remark
Contrast Ratio	C/R	$\theta = 0^\circ$	800	1000	-	-	Note(4)
NTSC Ratio	S	$\theta = 0^\circ$	65	70	-	%	Note(7)
Luminance	L	$\theta = 0^\circ$	232	290	-	cd/m <sup>2</sup>	Note(5)
Luminance uniformity	UW	$\theta = 0^\circ$	70	80	-	%	Note(3)
Response Time	TR+ TF	25 °C	-	-	35	ms	Note(2)
Color Coordination	WX	$\theta = 0^\circ$ (Center) Normal viewing angle B/L On	-0.05	(0.652)	+0.05	NTSC (x,y)	Note(6)
	WY			(0.313)			
	RX			(0.329)			
	RY			(0.636)			
	GX			(0.137)			
	Gy			(0.058)			
	BX			(0.303)			
	BY			(0.334)			
Viewing Angle	$\theta L$	C/R>10	70	85	-	Degree	Note(1)
	$\theta R$		70	85	-		
	$\theta U$		70	85	-		
	$\theta D$		70	85	-		

Test Conditions:

1. VDD=3.3V, IF=20mA (Backlight current), the ambient temperature is+25°C.
2. The test systems refer to Note 8.

**Note1:** Definition of Viewing Angle: The viewing angle range that the CR>10

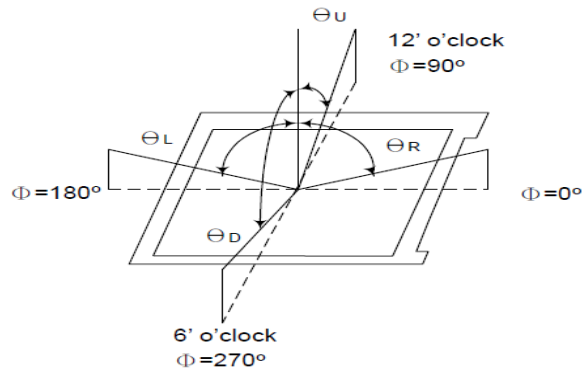

**Note2:** Definition of Response time: Sum of TR and TF

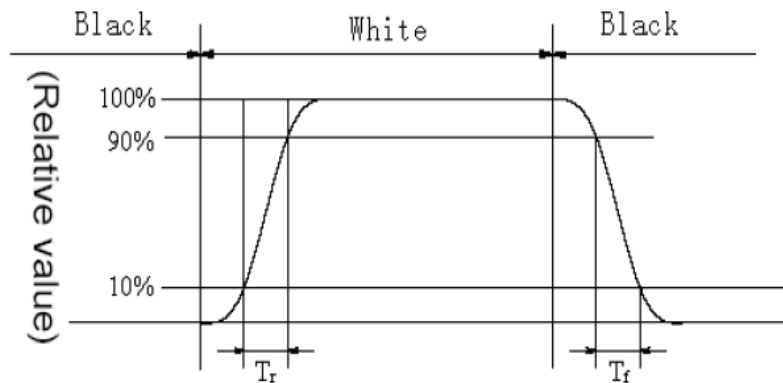

**Note 3:** Definition of Luminance Uniformity: Active area is divided into 9 measuring areas, every measuring point is placed at the center of each measuring area.

$$\text{Luminance Uniformity} = \frac{\text{Minimum Luminance}}{\text{Maximum Luminance}} \times 100\%$$



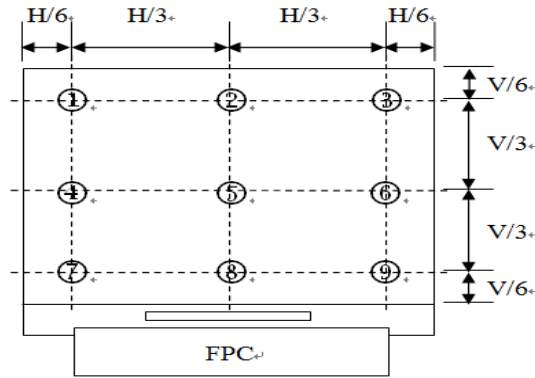

**Note4:** Definition of Contrast Ratio (CR): measured at the center point of panel

$$\text{Contrast ratio (CR)} = \frac{\text{Luminance measured when LCD on the "White" state}}{\text{Luminance measured when LCD on the "Black" state}}$$

**Note 5:**

Definition of

Luminance: Center Luminance of white is defined as luminance values of 1point average across the LCD surface.

**Note 6:** Definition of Color Chromaticity (CIE 1931)

Color coordinates of white & red, green, blue measured at center point of LCD.

**Note 7:** Definition of NTSC ratio:

$$\text{NTSC ratio} = \frac{\text{Area of RGB triangle}}{\text{Area of NTSC triangle}}$$

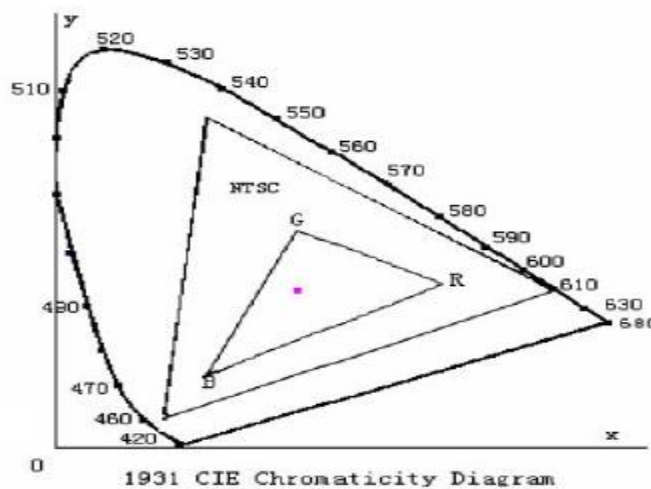

**Note 8:** Definition of optical measurement system.

The optical characteristics should be measured in dark room. After 5 minutes operation, the optical properties are measured at the center point of the LCD screen. (Response time is measured by Photo detector TOPCON BM-7, Field of view: 1°/Height: 500mm.)

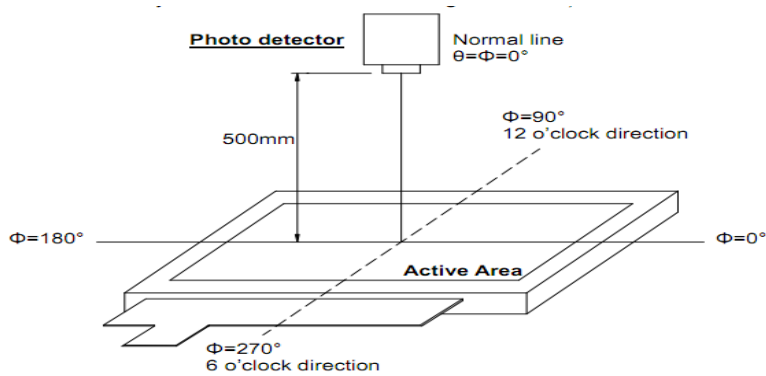

**7. Reliability**

<b>Item</b>	<b>Test Condition</b>	<b>SPECIFICATIONS</b>
Insulation Impedance	Apply a voltage of 250V DC between the metal outer rotating button and the base for 1 minute.	The resistance between the metal outer rotating button and the base is more than 100M $\Omega$ .
Rated Voltage	Apply a voltage of 300V AC between the metal outer rotating button and the base for 1 minute.	No insulation damage
Full Rotation Angle		360° (No stop point)
Rotation Torque		15 $\pm$ 7mN.m (150 $\pm$ 70gf.cm)
Positioning Points and Positions		20 positioning points (interval angle 18° $\pm$ 2 °)
Axial Compression Strength	At the shaft end, apply a static load force of 5Kgf along the axial direction and press down for 10 seconds (the screw is fixed on the face shell).	The shaft is not damaged and press is normal; The electrical performance is normal
Axial Drawing Strength	At the shaft end, apply a static load force of 5Kgf along the axial direction and pull up for 10 seconds (the screw is fixed on the face shell).	The shaft is not damaged and press is normal; The electrical performance is normal
Rotational Life	Under no-load condition, the shaft rotates 30000 at the speed of 600 ~ 1000 cycles / hour (1 cycle refers to 360° clockwise and 360° counterclockwise)	Torque: - 50% ~ + 10% of the initial value  Rotating button display LCD can be powered on and adjusted normally.
High Humidity Experiment	60 $\pm$ 3°C, 90 ~ 95%RH, 96 $\pm$ 4Hrs  Before function test and visual inspection, the product must have enough recovery time, at least 1.5 hours in normal temperature and humidity.	The surface of the outer rotating button is free of cracking and bubbling, and the display screen is free of OCA falling off.  Rotating button display LCD can be powered on and adjusted normally.

<p>High Temperature Experiment</p>	<p>70 ± 3°C, 96 ± 4Hrs</p> <p>Before function test and visual inspection, the product must have enough recovery time, at least 1.5 hours in normal temperature and humidity.</p>	<p>The surface of the outer rotating button is free of cracking and bubbling, and the display screen is free of OCA falling off.</p> <p>Rotating button display LCD can be powered on and adjusted normally.</p>																		
<p>Thermal Cycling Test</p>	<table border="1" data-bbox="368 568 981 1021"> <thead> <tr> <th>Step</th> <th>Temperature</th> <th>Duration</th> </tr> </thead> <tbody> <tr> <td>1</td> <td>-10°C</td> <td>0.5 hour</td> </tr> <tr> <td>2</td> <td>Standard atmospheric temperature conditions</td> <td>0.5 hour</td> </tr> <tr> <td>3</td> <td>60°C</td> <td>0.5 hour</td> </tr> <tr> <td>4</td> <td>Standard atmospheric temperature conditions</td> <td>0.5 hour</td> </tr> <tr> <td colspan="3" style="text-align: center;">Test cycle : 5 cycles</td> </tr> </tbody> </table> <p>Before function test and visual inspection, the product must have enough recovery time, at least 1.5 hours in normal temperature and humidity.</p>	Step	Temperature	Duration	1	-10°C	0.5 hour	2	Standard atmospheric temperature conditions	0.5 hour	3	60°C	0.5 hour	4	Standard atmospheric temperature conditions	0.5 hour	Test cycle : 5 cycles			<p>The surface of the outer rotating button is free of cracking and bubbling, and the display screen is free of OCA falling off.</p> <p>Rotating button display LCD can be powered on and adjusted normally.</p>
Step	Temperature	Duration																		
1	-10°C	0.5 hour																		
2	Standard atmospheric temperature conditions	0.5 hour																		
3	60°C	0.5 hour																		
4	Standard atmospheric temperature conditions	0.5 hour																		
Test cycle : 5 cycles																				
<p>Force of Pressing the Rotating Button</p>	<p>Apply an axial force to the face cover plate until it does not move, and take the large value in the force application process.</p>	<p>250±30gf</p>																		
<p>Movement Amount of Pressing the Rotating Button</p>	<p>Fix the product on the face cover plate, apply a static load force of twice the driving force directly above the cover plate, and measure the moving distance when the rotating button is pressed to immobility.</p>	<p>0.5±0.2 mm</p>																		
<p>Press Life of the Rotating Button</p>	<p>After the product is fixed, apply a pressing pressure of 250±30gf axially, press it to the end and release it to let it return freely. Press 100000 times. The pressing speed is 1500-1800 times per hour.</p>	<p>The pressing force is - 50% ~ + 10% of the initial value.</p> <p>Rotating button display LCD can be powered on and adjusted normally.</p> <p>The plastic part is free of damage, deformation and rotation is normal.</p>																		

**8. Product Packaging Information**

Storage environment and conditions:

1. It shall be stored in a well ventilated environment with temperature of - 15 °C ~ + 25 °C, relative humidity of 40% - 65% and no harmful gas around.
2. During storage and transportation, the stacking height of products shall not exceed 5 boxes.

Items	Normal Parameters	Limit Parameters	Material Valid Status	Remarks
Temperature	25°C	85°C	Normal	
Humidity	65%	95%	Normal	

9. Operation Process

9.1 Operation Flow Chart

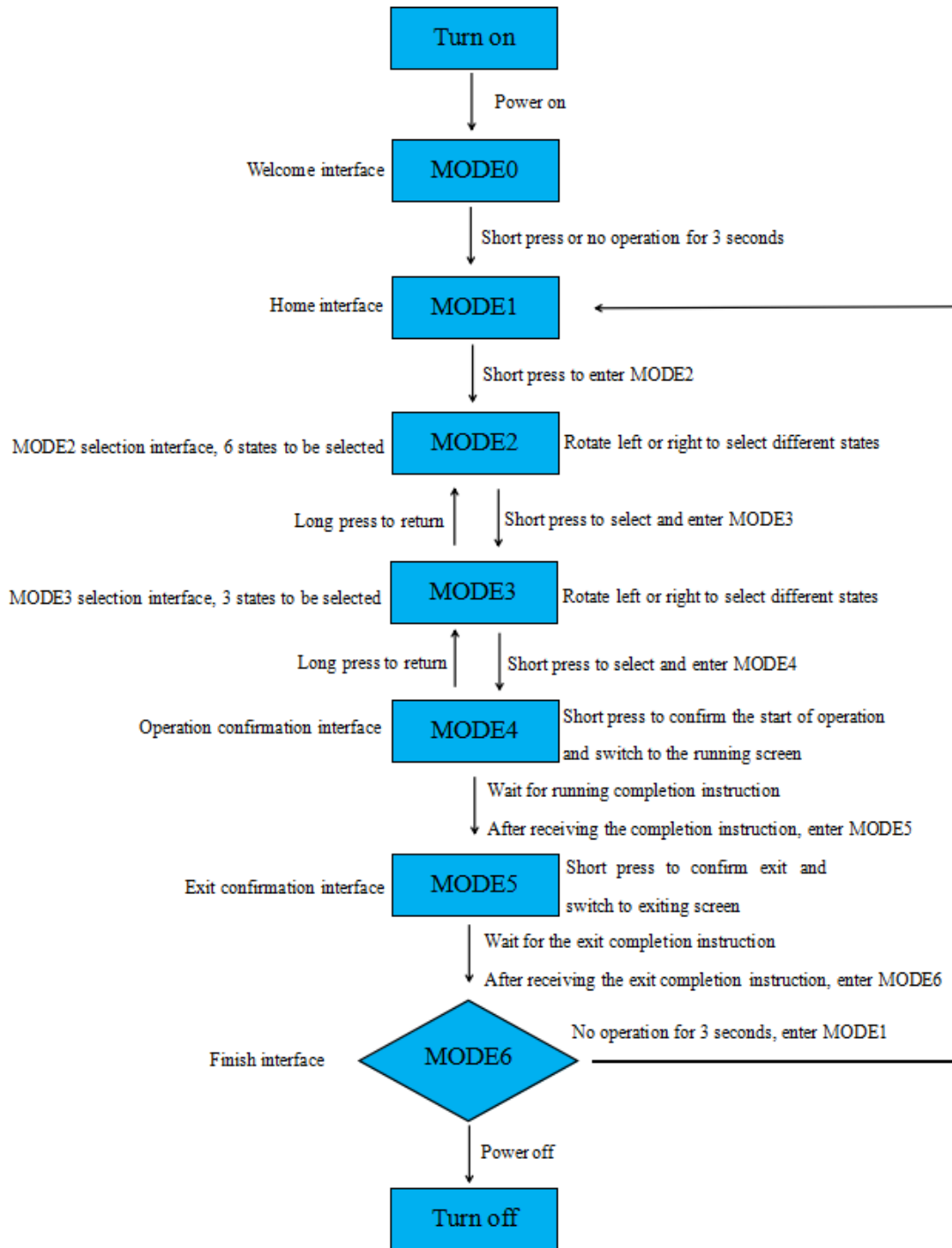

**9.2 Detailed Description of Operation****9.2.1 Power on:**

Turn on the module power supply switch and the module will be powered o;

**9.2.2 MODE0:**

Welcome interface, short press or no operation for 3 seconds to enter MODE1

**9.2.3 MODE1:**

Standby interface, short press to enter MODE2 for selection;

**9.2.4 MODE2:**

In MODE2 selection interface, rotate left or right to switch different states of MODE2. Short press to confirm the MODE2 state and enter MODE3. Long press to return to MODE1. There are six states for MODE2 to choose from;

**9.2.5 MODE3:**

In MODE3 selection interface, rotate left or right to switch different states of MODE3. Short press to confirm the MODE3 state and enter MODE4. Long press to return to MODE2. There are three states for MODE3 to choose from;

**9.2.6 MODE4:**

Operation Confirmation interface, short press to confirm the start of the operation, the display switches to the operating interface, long press to return to MODE3 selection interface, and enter MODE5 after receiving the operation completion instruction;

**9.2.7 MODE5:**

Pour out confirmation interface, short press to confirm the start of pour out, the display switches to the pouring out interface, and enter MODE6 after receiving the pour out completion instruction;

**9.2.8 MODE6:**

Finish interface, no operation for 3 seconds to enter MODE1;

**9.2.9 Power off:**

Turn off the power supply and the module will be powered off;

**10. Annular LED Status Indicator**

When the button is triggered, the color is switched randomly. When it is running or exiting, it is the breathing light effect.

**11. Communication Protocol**

UART serial port of TTL level is used for communication, asynchronous serial full duplex mode is adopted, baud rate is 115200bps, 8 data bits, no check bit, 1 stop bit;

**11.1 Communication Protocol Format**

SEQ	Data Content	Bytes	Value	Content Description
D1	Start code	1 Byte	0xA5	Fixed to 0xA5
D2	Start code	1 Byte	0x5A	Fixed to 0x5A
D3	Length	1 Byte	0x0A	Data length, including start code and check code
D4	Function word	1 Byte	0xA1	Command function
D5	Mode	1 Byte	[0-6]	Corresponding to seven different modes
D6	Reserve	1 Byte		Reserved value
D7	CRC1	1 Byte		CRC16 check value
D8	CRC2	1 Byte		CRC16 check value
D9	End code	1 Byte	0XFC	Fixed to 0XFC
D10	End code	1 Byte	0XCF	Fixed to 0XCF

**11.2 Communication Instruction Description****Mode Switching Instruction**

After the module is switched from MODE0-MODE6, it will continuously issue the instruction once per second. After receiving the return instruction and checking that it is consistent, it will stop issuing;

The module issues instructions:

D1	D2	D3	D4	D5	D6	D7	D8	D9	D10
0XA5	0X5A	0X0A	0XA1	MODE	Reserve	CRC1	CRC2	0XFC	0XCF

MODE:0-6, representing the current mode of the module;

Return instruction:

D1	D2	D3	D4	D5	D6	D7	D8	D9	D10
0XA5	0X5A	0X0A	0XB1	MODE	Reserve	CRC1	CRC2	0XFC	0XCF



MODE:0-6, which represents the mode received by the lower level. When it is consistent with the current mode of the module, it is judged that the lower level has correctly received the mode switching instruction, and the module will stop issuing the mode switching instruction;

#### MODE2 Selection Instruction

When the module selects MODE2 state (switches and enters Mode3), in addition to sending the switching mode instruction, it will also send the MODE2 selection instruction. Like the switching mode instruction, it will be sent continuously once a second before the return instruction is received and the inspection is consistent;

The module issues instructions:

D1	D2	D3	D4	D5	D6	D7	D8	D9	D10
0XA5	0X5A	0X0A	0XA2	MODE2	Reserve	CRC1	CRC2	0XFC	0XCF

MODE2:0-5, which represents the selection of six states of MODE2.

Return instruction:

D1	D2	D3	D4	D5	D6	D7	D8	D9	D10
0XA5	0X5A	0X0A	0XB2	MODE2	Reserve	CRC1	CRC2	0XFC	0XCF

MODE2:0-5, which represents the MODE2 states received by the lower level. When it is consistent with the MODE2 status of the module, it is judged that the lower level has received the correct MODE2 state value. At this time, the module will stop issuing the MODE2 selection instruction.

#### MODE3 Selection Instruction

When the module selects MODE3 state (switches and enters MODE4), in addition to sending the switching mode instruction, it will also send the MODE3 selection instruction. Like the switching mode instruction, it will be sent continuously once per second before the return instruction is received and the inspection is consistent;

The module issues instructions:

D1	D2	D3	D4	D5	D6	D7	D8	D9	D10
0XA5	0X5A	0X0A	0XA3	MODE3	Reserve	CRC1	CRC2	0XFC	0XCF

MODE3:1-3, which represents the selection of three states of MODE3.

Return instruction:

D1	D2	D3	D4	D5	D6	D7	D8	D9	D10
0XA5	0X5A	0X0A	0XB3	MODE3	Reserve	CRC1	CRC2	0XFC	0XCF

Represents the MODE3 states received by the lower level. When it is consistent with the MODE3 state of the module, it is judged that the lower level has received the correct MODE3 state value. At this time, the module will stop issuing the MODE3 selection instruction.

**Start Instruction**

When the module is in the MODE4 state and short press the button to enter the operation confirmation state, issue the start instruction. Like the mode switching instruction, it is continuously sent once per second before receiving the return instruction (no consistent inspection is required);

The module issues instructions:

D1	D2	D3	D4	D5	D6	D7	D8	D9	D10
0XA5	0X5A	0X0A	0XA4	0X01	Reserve	CRC1	CRC2	0XFC	0XCF

Return instruction:

D1	D2	D3	D4	D5	D6	D7	D8	D9	D10
0XA5	0X5A	0X0A	0XB4	ST	Reserve	CRC1	CRC2	0XFC	0XCF

ST=1, indicates start; ST=2, indicates finish; When receiving ST=2, the module will switch from MODE4 to MODE5;

**Exit Instruction**

When the module is in the MODE5 state and short press the button to enter the exit confirmation state, issue the exit instruction. Like the mode switching instruction, it is continuously sent once per second before receiving the return instruction (no consistent inspection is required);

The module issues instructions:

D1	D2	D3	D4	D5	D6	D7	D8	D9	D10
0XA5	0X5A	0X0A	0XA5	0X01	Reserve	CRC1	CRC2	0XFC	0XCF

Return instruction:

D1	D2	D3	D4	D5	D6	D7	D8	D9	D10
0XA5	0X5A	0X0A	0XB5	ST	Reserve	CRC1	CRC2	0XFC	0XCF

ST=1, indicates exit; ST=2, indicates exit complete; When receiving ST=2, the module will switch from MODE6 to MODE6.

**11.3 Check Bit Description**

Please refer to the following code to calculate the check bit:

```
#define MODBUSLIB_ZERO          (0)

#define MODBUSLIB_M_DATALENTH_MAX    (0x7D)

#define MODBUSLIB_LOSTCOMM_THRESHOLD    (5)

/* CRC Related */

#define MODBUSLIB_FIXED_POLY_VALUE    (0Xa001)

#define MODBUSLIB_BYTE_LENGTH    (7)

#define MODBUSLIB_CRC_INITIAL_VALUE    (0Xffff) /* 0Xffff */

U16 Modbus_OneByteCrc(U16 u16Crc, U8 u8_Data)
{
    U16 u8_BitCounter = MODBUSLIB_ZERO;
    u16Crc = (u16Crc ^ u8_Data);
```

```
    for (u8_BitCounter = MODBUSLIB_ZERO; u8_BitCounter <= MODBUSLIB_BYTE_LENGTH;
u8_BitCounter++)
    {
        if (0x01 == (u16Crc & 0x01))/*if LSB is one*/
        {
            u16Crc >>= 1;/*if LSB is not one then rotate data right only once*/
            u16Crc = u16Crc ^ MODBUSLIB_FIXED_POLY_VALUE;/*again XOR with fixed polynomial
value*/
        }
        else
        {
            u16Crc >>= 1;/*if LSB is not one then rotate data right only once*/
        }
    }/*end of for(ucByte = MODBUSLIB_ZERO; ucByte <= BYTE_LENGTH; ucByte++)*/

    return (u16Crc);
}
U16 Modbus_Calculate16CRC(U8 *pu8_Data, U8 u8_Length, U16 u16CRCInitialValue)
{
    U8 u8_Loop = MODBUSLIB_ZERO;
    U16 u16CRC_Value = MODBUSLIB_ZERO;

    u16CRC_Value = u16CRCInitialValue; /* Initial CRC value */
    for (u8_Loop = MODBUSLIB_ZERO; u8_Loop < u8_Length; u8_Loop++)
    {
        u16CRC_Value = Modbus_OneByteCrc(u16CRC_Value, *pu8_Data++);
    }
    return (u16CRC_Value);
}
```

**12.Secondary Development Description**

This module has the function of secondary development. Users can replace the interface of the module through the following methods.

**12.1 Preparation of Software Tools and Picture Materials**

Download tools: USB to serial port tool;

Software Tools:

1: Batch program-----BmpToBinForENC21.exe

2: Picture download software-----PicDownload\_V2.01.exe

Picture Materials:

The user replaces the pictures with corresponding serial numbers as required, and the pictures are in BMP format, and all pictures need to be placed in BMP\_FIL folder, the corresponding table of picture naming is as follows:

Picture Naming	Corresponding Interface
000.BMP	Welcome interface
001.BMP	Standby interface
101.BMP	Work-pattern 1 interface
102.BMP	Work-pattern 2 interface
103.BMP	Work-pattern 3 interface
104.BMP	Work-pattern 4 interface
105.BMP	Work-pattern 5 interface
106.BMP	Work-pattern 6 interface
201.BMP	Setting the working status 1 interface
202.BMP	Setting the working status 2 interface
203.BMP	Setting the working status 4 interface
301.BMP	Working running status 1 interface
302.BMP	Working running status 2 interface
303.BMP	Working running status 3 interface
304.BMP	Working running status 4 interface
401.BMP	Finish interface
501~505.BMP	Picture of the demo run countdown
601~605.BMP	Demo cup countdown picture

**12.2 Image Processing**

1. Prepare BMP\_ File folder and place BMP\_FILE folder and batch program BmpToBinForENC21.exe in the same folder, and an empty folder named BMP\_DATA needs to be created in this folder, and then execute the batch program BmpToBinForENC21.exe ;

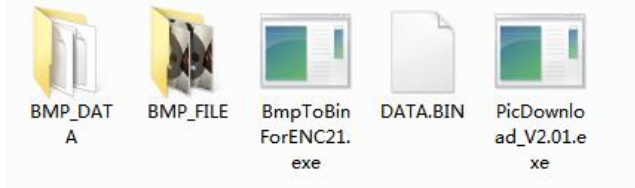

2. After execution, in BMP\_DATA folder, two files will be generated in it. BMPDATA.BIN is a data file in which all picture data are placed in turn, TABLE.BIN is a table file, which is also equivalent to an index file;

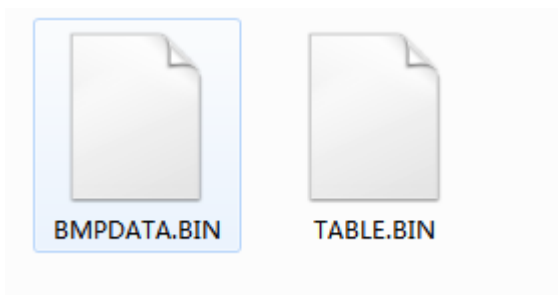

### 13.3 Data Download

1. After generating BMPDATA.BIN file and TABLE.BIN file, connect the module to the computer through the serial port. The connection characteristics can be tested by sending instructions with the serial port assistant to ensure that the connection is normal, and then download the data with the picture download software;

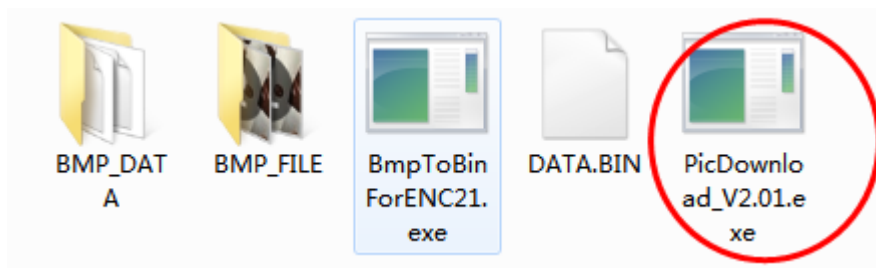

2. Double click 图片下载软件.exe, enter the correct serial port number in the window to start the download. After the download, the window will automatically close and complete the replacement of picture data at this time;

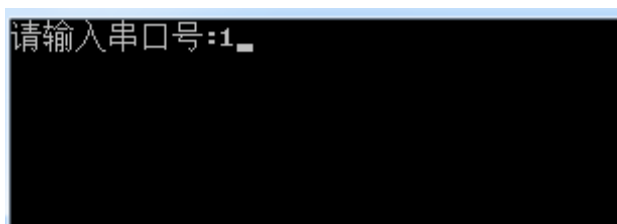

**Appendix 1 application case: coffee machine controller process**

