

## Data sheet | Item number: 280-944/281-591

Component terminal block; double-deck; with end plate; with 1.5KE82C TVS diode; 60 VDC; for DIN-rail 35 x 15 and 35 x 7.5; 2.5 mm<sup>2</sup>; CAGE CLAMP®; 2,50 mm<sup>2</sup>; gray

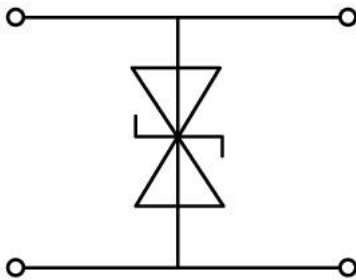

[www.wago.com/280-944/281-591](http://www.wago.com/280-944/281-591)

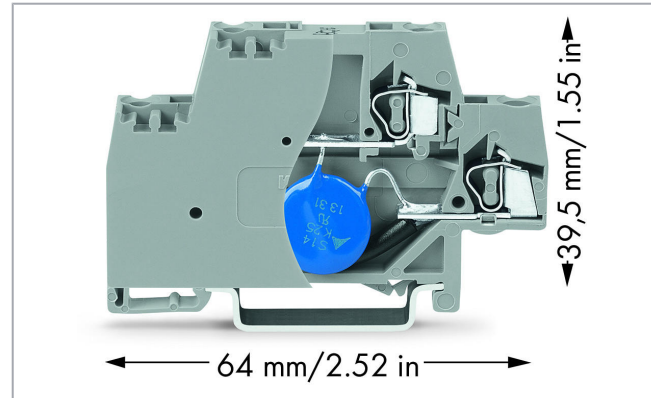
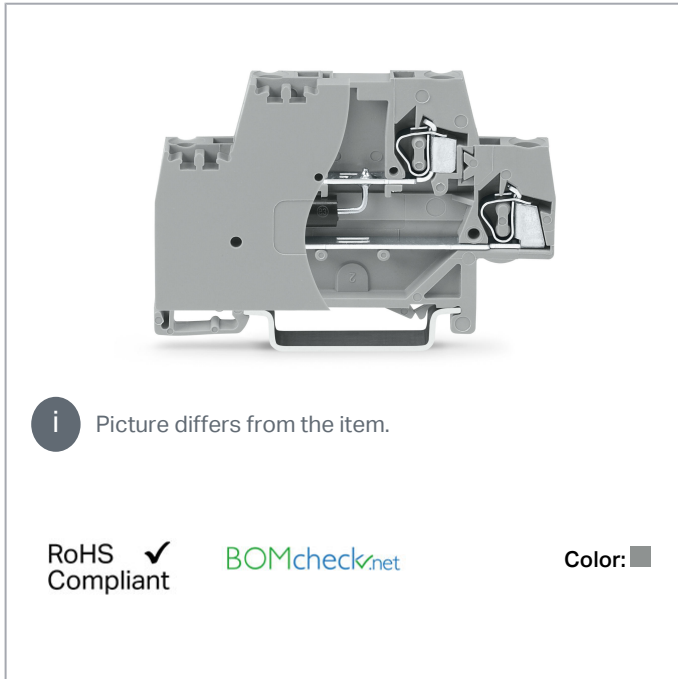

### Item description

#### Short description:

This component terminal block with surge suppression device and end plate is equipped with a TVS diode.

#### Features:

- Protect your system against overvoltage
- Slim, space-saving design
- Control operational costs by preventing expensive, unplanned downtime

Subject to changes. Please also observe the further product documentation!

WAGO Kontakttechnik GmbH & Co. KG  
Hansastr. 27  
32423 Minden  
Phone: +49571 887-0 | Fax: +49571 887-169  
Email: [info.de@wago.com](mailto:info.de@wago.com) | Web: [www.wago.com](http://www.wago.com)

Do you have any questions about our products?  
We are always happy to take your call at +49 (571) 887-44222.

- High operational reliability and system uptime

## Data

### Electrical data

|  |                 |
|--|-----------------|
| Nominal operating voltage                      | DC 60 V         |
| Continuous operating voltage (max.)            | DC 70 V         |
| Rated continuous current                       | 20 A            |
| Nominal discharge current (8/20 $\mu$ s), line | 69 A            |
| Protection level (8/20 $\mu$ s)                | $\leq$ DC 146 V |
| Capacitance                                    | $\leq$ 1.35 nF  |

### Connection data

|                            |  |
|----------------------------|--|
| Connection points (number) | 4  |
| Connection technology      | CAGE CLAMP®                                  |
| Solid conductor            | 0.08 ... 2.5 mm <sup>2</sup> / 28 ... 14 AWG |
| Fine-stranded conductor    | 0.08 ... 2.5 mm <sup>2</sup> / 28 ... 14 AWG |
| Strip length               | 8 ... 9 mm / 0.31 ... 0.35 inch              |

### Physical data

|                                    |                      |
|------------------------------------|----------------------|
| Width                              | 10 mm / 0.394 inch   |
| Height from upper-edge of DIN-rail | 39.5 mm / 1.555 inch |
| Depth                              | 64 mm / 2.52 inch    |

### Mechanical data

|               |                |
|---------------|----------------|
| Design        | with end plate |
| Mounting type | DIN-35 rail    |

### Material data

|        |        |
|--------|--------|
| Color  | gray   |
| Weight | 14.2 g |

### Commercial data

|                   |                                  |
|-------------------|----------------------------------|
| Product Group     | 1 (Rail Mounted Terminal Blocks) |
| Packaging type    | BOX                              |
| Country of origin | DE                               |

Subject to changes. Please also observe the further product documentation!

|                       |               |
|-----------------------|---------------|
| GTIN                  | 4050821515067 |
| Customs tariff number | 85369010000   |

## Compatible products

### tools



**Item no.: 210-720**

Operating tool; Blade: 3.5 x 0.5 mm; with a partially insulated shaft; multicoloured

[www.wago.com/210-720](http://www.wago.com/210-720)

### Jumper



**Item no.: 280-482**

Jumper; 2-way; insulated; gray

[www.wago.com/280-482](http://www.wago.com/280-482)



**Item no.: 280-483**

Jumper; 3-way; insulated; gray

[www.wago.com/280-483](http://www.wago.com/280-483)



**Item no.: 280-484**

Jumper; 4-way; insulated; gray

[www.wago.com/280-484](http://www.wago.com/280-484)



**Item no.: 280-485**

Jumper; 5-way; insulated; gray

[www.wago.com/280-485](http://www.wago.com/280-485)



**Item no.: 280-490**

Jumper; 10-way; insulated; gray

[www.wago.com/280-490](http://www.wago.com/280-490)



**Item no.: 280-492**

Jumper; 2-way; insulated; gray

[www.wago.com/280-492](http://www.wago.com/280-492)

### Marking accessories



**Item no.: 2009-145**

Mini-WSB Inline; for Smart Printer; 1700 pieces on roll; stretchable 5 - 5.2 mm; plain; snap-on type; white

[www.wago.com/2009-145](http://www.wago.com/2009-145)



**Item no.: 2009-145/000-002**

Mini-WSB Inline; for Smart Printer; 1700 pieces on roll; stretchable 5 - 5.2 mm; plain; snap-on type; yellow

[www.wago.com/2009-145/000-002](http://www.wago.com/2009-145/000-002)



**Item no.: 2009-145/000-005**

Mini-WSB Inline; for Smart Printer; 1700 pieces on roll; stretchable 5 - 5.2 mm; plain; snap-on type; red

[www.wago.com/2009-145/000-005](http://www.wago.com/2009-145/000-005)



**Item no.: 2009-145/000-006**

Mini-WSB Inline; for Smart Printer; 1700 pieces on roll; stretchable 5 - 5.2 mm; plain; snap-on type; blue

[www.wago.com/2009-145/000-006](http://www.wago.com/2009-145/000-006)



**Item no.: 2009-145/000-007**

Mini-WSB Inline; for Smart Printer; 1700 pieces on roll; stretchable 5 - 5.2 mm; plain; snap-on type; gray

[www.wago.com/2009-145/000-007](http://www.wago.com/2009-145/000-007)



**Item no.: 2009-145/000-012**















Mini-WSB Inline; for Smart Printer; 1700 pieces on roll; stretchable 5 - 5.2 mm; plain; snap-on type; orange

[www.wago.com/2009-145/000-012](http://www.wago.com/2009-145/000-012)

Subject to changes. Please also observe the further product documentation!

WAGO Kontakttechnik GmbH & Co. KG  
 Hansastr. 27  
 32423 Minden  
 Phone: +49571 887-0 | Fax: +49571 887-169  
 Email: [info.de@wago.com](mailto:info.de@wago.com) | Web: [www.wago.com](http://www.wago.com)

Do you have any questions about our products?  
 We are always happy to take your call at +49 (571) 887-44222.

|  |   |  |
|--|---|--|
|    | <p><b>Item no.: 2009-145/000-023</b><br/>Mini-WSB Inline; for Smart Printer; 1700 pieces on roll; stretchable 5 - 5.2 mm; plain; snap-on type; green</p>  | <a href="http://www.wago.com/2009-145/000-023">www.wago.com/2009-145/000-023</a> |
|    | <p><b>Item no.: 2009-145/000-024</b><br/>Mini-WSB Inline; for Smart Printer; 1700 pieces on roll; stretchable 5 - 5.2 mm; plain; snap-on type; violet</p> | <a href="http://www.wago.com/2009-145/000-024">www.wago.com/2009-145/000-024</a> |
|    | <p><b>Item no.: 248-501</b><br/>Miniature WSB Quick marking system; plain; Marker width 5 mm; 10 strips with 10 markers per card</p>                      | <a href="http://www.wago.com/248-501">www.wago.com/248-501</a>                   |
|    | <p><b>Item no.: 248-501/000-002</b><br/>Mini-WSB marking card; as card; not stretchable; plain; snap-on type; yellow</p>                                  | <a href="http://www.wago.com/248-501/000-002">www.wago.com/248-501/000-002</a>   |
|    | <p><b>Item no.: 248-501/000-005</b><br/>Mini-WSB marking card; as card; not stretchable; plain; snap-on type; red</p>                                     | <a href="http://www.wago.com/248-501/000-005">www.wago.com/248-501/000-005</a>   |
|    | <p><b>Item no.: 248-501/000-006</b><br/>Mini-WSB marking card; as card; not stretchable; plain; snap-on type; blue</p>                                    | <a href="http://www.wago.com/248-501/000-006">www.wago.com/248-501/000-006</a>   |
|    | <p><b>Item no.: 248-501/000-007</b><br/>Mini-WSB marking card; as card; not stretchable; plain; snap-on type; gray</p>                                    | <a href="http://www.wago.com/248-501/000-007">www.wago.com/248-501/000-007</a>   |
|  | <p><b>Item no.: 248-501/000-012</b><br/>Mini-WSB marking card; as card; not stretchable; plain; snap-on type; orange</p>                                  | <a href="http://www.wago.com/248-501/000-012">www.wago.com/248-501/000-012</a>   |
|  | <p><b>Item no.: 248-501/000-017</b><br/>Mini-WSB marking card; as card; not stretchable; plain; snap-on type; light green</p>                             | <a href="http://www.wago.com/248-501/000-017">www.wago.com/248-501/000-017</a>   |
|  | <p><b>Item no.: 248-501/000-023</b><br/>Mini-WSB marking card; as card; not stretchable; plain; snap-on type; green</p>                                   | <a href="http://www.wago.com/248-501/000-023">www.wago.com/248-501/000-023</a>   |
|  | <p><b>Item no.: 248-501/000-024</b><br/>Mini-WSB marking card; as card; not stretchable; plain; snap-on type; violet</p>                                  | <a href="http://www.wago.com/248-501/000-024">www.wago.com/248-501/000-024</a>   |
| <b>Insulation stop</b>   |   |  |
|  | <p><b>Item no.: 280-470</b><br/>Insulation stop; 0.08 - 0.2 mm<sup>2</sup> "s" (0.14 mm<sup>2</sup> "f-st"); 5 pieces/strip; white</p>                    | <a href="http://www.wago.com/280-470">www.wago.com/280-470</a>                   |
|  | <p><b>Item no.: 280-471</b><br/>Insulation stop; 0.25 - 0.5 mm<sup>2</sup>; 5 pieces/strip; light gray</p>  | <a href="http://www.wago.com/280-471">www.wago.com/280-471</a>                   |
|  | <p><b>Item no.: 280-472</b><br/>Insulation stop; 0.75 - 1 mm<sup>2</sup>; 5 pieces/strip</p>  | <a href="http://www.wago.com/280-472">www.wago.com/280-472</a>                   |

Subject to changes. Please also observe the further product documentation!



## Downloads

### Documentation

#### Bid Text

|                                |             |                |          |
|--------------------------------|-------------|----------------|----------|
| 280-944/281-591<br>X81 - Datei | 19. 2. 2019 | xml<br>3.3 kB  | Download |
| 280-944/281-591<br>doc - Datei | 11. 2. 2015 | doc<br>26.1 kB | Download |

#### Additional Information

|  |         |                 |          |
|--|---------|-----------------|----------|
| Disposal; Electrical and electronic equipment, Packaging | V 1.0.0 | pdf<br>265.8 kB | Download |
|--|---------|-----------------|----------|

## CAD/CAE-Data

### CAE data

|                                   |     |          |
|-----------------------------------|-----|----------|
| EPLAN Data Portal 280-944/281-591 | URL | Download |
| WSCAD Universe 280-944/281-591    | URL | Download |
| WSCAD Universe 280-944/281-591    | URL | Download |
| EPLAN Data Portal 280-944/281-591 | URL | Download |

## Environmental Product Compliance

### Compliance Search

|  |     |          |
|--|-----|----------|
| Environmental Product Compliance 280-944/281-591<br>Component terminal block; double-deck; with end plate; with 1.5KE82C TVS diode;<br>60 VDC; for DIN-rail 35 x 15 and 35 x 7.5; 2.5 mm <sup>2</sup> ; CAGE CLAMP®; 2,50 mm <sup>2</sup> ; gray | URL | Download |
|--|-----|----------|

## Installation Notes

Subject to changes. Please also observe the further product documentation!

WAGO Kontakttechnik GmbH & Co. KG  
 Hansastr. 27  
 32423 Minden  
 Phone: +49571 887-0 | Fax: +49571 887-169  
 Email: [info.de@wago.com](mailto:info.de@wago.com) | Web: [www.wago.com](http://www.wago.com)

Do you have any questions about our products?  
 We are always happy to take your call at +49 (571) 887-44222.