

BC65-TE-B User Guide

NB-IoT Module Series

Version: 1.0

Date: 2020-08-10

Status: Released



Our aim is to provide customers with timely and comprehensive service. For any assistance, please contact our company headquarters:

Quectel Wireless Solutions Co., Ltd.

Building 5, Shanghai Business Park Phase III (Area B), No.1016 Tianlin Road, Minhang District, Shanghai 200233, China

Tel: +86 21 5108 6236 Email: info@quectel.com

Or our local office. For more information, please visit: <http://www.quectel.com/support/sales.htm>.

For technical support, or to report documentation errors, please visit:

<http://www.quectel.com/support/technical.htm> or email to support@quectel.com.

GENERAL NOTES

QUECTEL OFFERS THE INFORMATION AS A SERVICE TO ITS CUSTOMERS. THE INFORMATION PROVIDED IS BASED UPON CUSTOMERS' REQUIREMENTS. QUECTEL MAKES EVERY EFFORT TO ENSURE THE QUALITY OF THE INFORMATION IT MAKES AVAILABLE. QUECTEL DOES NOT MAKE ANY WARRANTY AS TO THE INFORMATION CONTAINED HEREIN, AND DOES NOT ACCEPT ANY LIABILITY FOR ANY INJURY, LOSS OR DAMAGE OF ANY KIND INCURRED BY USE OF OR RELIANCE UPON THE INFORMATION. ALL INFORMATION SUPPLIED HEREIN IS SUBJECT TO CHANGE WITHOUT PRIOR NOTICE.

DISCLAIMER

WHILE QUECTEL HAS MADE EFFORTS TO ENSURE THAT THE FUNCTIONS AND FEATURES UNDER DEVELOPMENT ARE FREE FROM ERRORS, IT IS POSSIBLE THAT THESE FUNCTIONS AND FEATURES COULD CONTAIN ERRORS, INACCURACIES AND OMISSIONS. UNLESS OTHERWISE PROVIDED BY VALID AGREEMENT, QUECTEL MAKES NO WARRANTIES OF ANY KIND, IMPLIED OR EXPRESS, WITH RESPECT TO THE USE OF FEATURES AND FUNCTIONS UNDER DEVELOPMENT. TO THE MAXIMUM EXTENT PERMITTED BY LAW, QUECTEL EXCLUDES ALL LIABILITY FOR ANY LOSS OR DAMAGE SUFFERED IN CONNECTION WITH THE USE OF THE FUNCTIONS AND FEATURES UNDER DEVELOPMENT, REGARDLESS OF WHETHER SUCH LOSS OR DAMAGE MAY HAVE BEEN FORESEEABLE.

COPYRIGHT

THE INFORMATION CONTAINED HERE IS PROPRIETARY TECHNICAL INFORMATION OF QUECTEL WIRELESS SOLUTIONS CO., LTD. TRANSMITTING, REPRODUCTION, DISSEMINATION AND EDITING OF THIS DOCUMENT AS WELL AS UTILIZATION OF THE CONTENT WITHOUT PERMISSION ARE FORBIDDEN. OFFENDERS WILL BE HELD LIABLE FOR PAYMENT OF DAMAGES. ALL RIGHTS ARE RESERVED IN THE EVENT OF A PATENT GRANT OR REGISTRATION OF A UTILITY MODEL OR DESIGN.

Copyright © Quectel Wireless Solutions Co., Ltd. 2020. All rights reserved.

About the Document

Revision History

Version	Date	Author	Description
1.0	2020-08-10	Ewent LU/ Jerry WANG/ Jack WU/ Louis GU	Initial

Contents

About the Document	2
Contents	3
Table Index.....	4
Figure Index	5
1 Introduction	6
1.1. Safety Information.....	7
2 Product Concept	8
2.1. Key Features	8
2.2. Functional Diagram.....	10
2.3. Interface Distribution Diagram.....	11
2.4. Arduino Interface Definition	13
3 Operation Procedures	14
3.1. Operation Procedure with Single Board	14
3.1.1. Interface Diagram.....	14
3.1.2. Operation Procedure.....	15
3.2. Operation Procedures with Multi-boards.....	16
3.2.1. Interface Diagram.....	16
3.2.2. Operation Procedure.....	18
3.2.3. Description of Pin Connection.....	18
4 Electrical Performance & Reliability	20
4.1. Absolute Maximum Ratings.....	20
4.2. Operating and Storage Temperatures	20
5 Mechanical Dimensions	22
5.1. Mechanical Dimensions of BC65-TE-B.....	22
5.2. Top and Bottom Views of BC65-TE-B	23
6 BC65-TE-B Kit and Accessories.....	24
6.1. BC65-TE-B Kit	24
6.2. BC65-TE-B Kit Accessories.....	25
7 Appendix A References.....	26

Table Index

Table 1: Key Features of BC65-TE-B.....	8
Table 2: Interfaces of BC65-TE-B	11
Table 3: Pin Connection between BC65-TE-B and STM32-L476RG MCU	18
Table 4: Absolute Maximum Ratings	20
Table 5: Operating and Storage Temperatures	20
Table 6: Accessories List.....	25
Table 7: Related Document.....	26
Table 8: Terms and Abbreviations	26

Figure Index

Figure 1: Functional Diagram of BC65-TE-B	10
Figure 2: Interface Distribution Diagram of BC65-TE-B	11
Figure 3: Arduino Interface Definition.....	13
Figure 4: Interface Diagram of Using BC65-TE-B Alone	14
Figure 5: UART Ports Displayed on PC	15
Figure 6: Interface Diagram of Using Multi-boards	16
Figure 7: STM32 Nucleo-64 Interface Diagram (Top View).....	17
Figure 8: STM32 Nucleo-64 Modification Diagram (Bottom View)	17
Figure 9: ST-LINK Interface Displayed on PC	18
Figure 10: Pin Connection between BC65-TE-B and STM32-L476RG MCU	19
Figure 11: Dimensions of BC65-TE-B (Top View).....	22
Figure 12: Top View of the BC65-TE-B.....	23
Figure 13: Bottom View of the BC65-TE-B	23
Figure 14: BC65-TE-B Kit Assembly	24
Figure 15: BC65-TE-B and the Accessories	25

1 Introduction

To help you develop applications with Quectel BC65 module conveniently, Quectel supplies a corresponding development board (BC65-TE-B) to test the module. This document helps you quickly understand BC65-TE-B interface specifications, electrical and mechanical details and know how to use it.

1.1. Safety Information

The following safety precautions must be observed during all phases of operation, such as usage, service or repair of any cellular terminal or mobile incorporating BC65 module. Manufacturers of the cellular terminal should notify users and operating personnel of the following safety information by incorporating these guidelines into all manuals of the product. Otherwise, Quectel assumes no liability for customers' failure to comply with these precautions.



Full attention must be paid to driving at all times in order to reduce the risk of an accident. Using a mobile while driving (even with a handsfree kit) causes distraction and can lead to an accident. Please comply with laws and regulations restricting the use of wireless devices while driving.



Switch off the cellular terminal or mobile before boarding an aircraft. The operation of wireless appliances in an aircraft is forbidden to prevent interference with communication systems. If there is an Airplane Mode, it should be enabled prior to boarding an aircraft. Please consult the airline staff for more restrictions on the use of wireless devices on an aircraft.



Wireless devices may cause interference on sensitive medical equipment, so please be aware of the restrictions on the use of wireless devices when in hospitals, clinics or other healthcare facilities.



Cellular terminals or mobiles operating over radio signals and cellular network cannot be guaranteed to connect in all possible conditions (for example, with unpaid bills or with an invalid (U)SIM card). When emergent help is needed in such conditions, use emergency call. In order to make or receive a call, the cellular terminal or mobile must be switched on in a service area with adequate cellular signal strength.



Your cellular terminal or mobile contains a transmitter and receiver. When it is ON, it receives and transmits radio frequency energy. RF interference can occur if it is used close to TV set, radio, computer or other electric equipment.



In locations with potentially explosive atmospheres, obey all posted signs to turn off wireless devices such as your phone or other cellular terminals. Areas with potentially explosive atmospheres include fuelling areas, below decks on boats, fuel or chemical transfer or storage facilities, areas where the air contains chemicals or particles such as grain, dust or metal powders.

2 Product Concept

BC65-TE-B is a NB-IoT development board which supports Arduino interfaces. Designed in 70.0 mm × 74.0 mm × 1.6 mm form factor, BC65-TE-B can be used to develop and debug applications which communicate with mobile network operators' infrastructure equipment through NB-IoT radio protocols (3GPP Rel-13 and Rel-14).

2.1. Key Features

The following table describes the detailed features of BC65-TE-B.

Table 1: Key Features of BC65-TE-B

Features	Details
Power Supply	<p>USB interface: Supply voltage: 4.75–5.25 V typical supply voltage: 5.0 V</p> <p>Arduino interface: Supply voltage: 4.75–5.25 V typical supply voltage: 5.0 V</p> <p>Power supply interface: Supply voltage: 5.0 V</p>
Transmitting Power	23 dBm ±2 dB
Temperature Range	<p>Operating temperature: -25°C to +75°C ¹⁾</p> <p>Extended temperature: -40°C to +85°C ²⁾</p> <p>Storage temperature: -40°C to +90°C</p>
USIM Interface	Supports 1.8/3.0 V external USIM cards
UART Switch	Switches communication objects of the main UART port of the BC65 module
USB Interface	<p>Currently supports two UART ports:</p> <p>Main Port (Ch A):</p> <ul style="list-style-type: none"> ● Transmits data (including AT commands) ● The default baud rate is 9600 bps <p>Debug Port (Ch B):</p>

	<ul style="list-style-type: none"> ● Obtains underlying logs through software debugging with CoolWatcher, a debugging tool ● Upgrades software with QFlash ● The default baud rate: 921600 bps <p>Auxiliary Port* (only for QuecOpen solution)</p> <ul style="list-style-type: none"> ● Transmits data (including AT commands) ● The default baud rate is 9600 bps
Arduino Interfaces	Connects with STM32 Nucleo-64 development board
RESET Button	Resets the BC65 module
PWRKEY Button	Powers on the BC65 module
Physical Characteristics	Size: (70.0 ±0.15) mm × (74.0 ±0.15) mm × (1.6 ±0.15) mm
Firmware Upgrade	Upgrades firmware via Debug Port and DFOTA
Antenna Interface	Connects to antenna pad with 50 Ω impedance control
SMS*	Text and PDU mode

NOTES

1. ¹⁾ Within the operation temperature range, the module meets 3GPP specifications.
2. ²⁾ Within the extended temperature range, the module remains the ability to establish and maintain functions such as SMS, data transmission, without any unrecoverable malfunction. Radio spectrum and radio network will not be influenced, while one or more specifications, such as P_{out}, may undergo a reduction in value, exceeding the specified tolerances of 3GPP. When the temperature returns to the normal operating temperature level, the module will meet 3GPP specifications again.
3. “*” means under development.

2.2. Functional Diagram

The following figure shows a block diagram of BC65-TE-B.

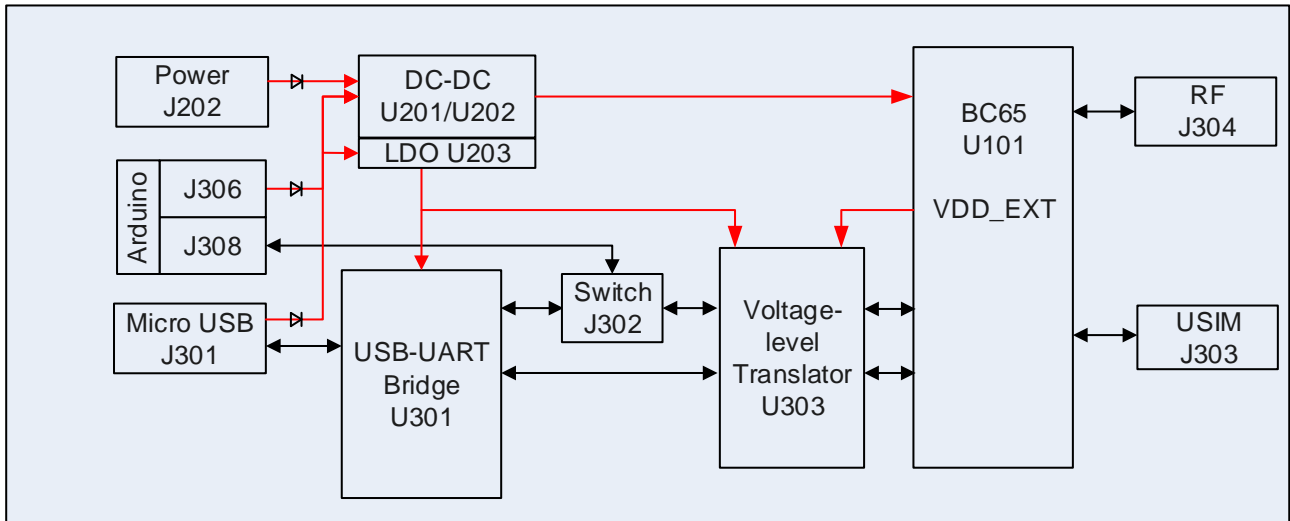

Figure 1: Functional Diagram of BC65-TE-B

2.3. Interface Distribution Diagram

The following figure shows the interface distribution diagram of BC65-TE-B.

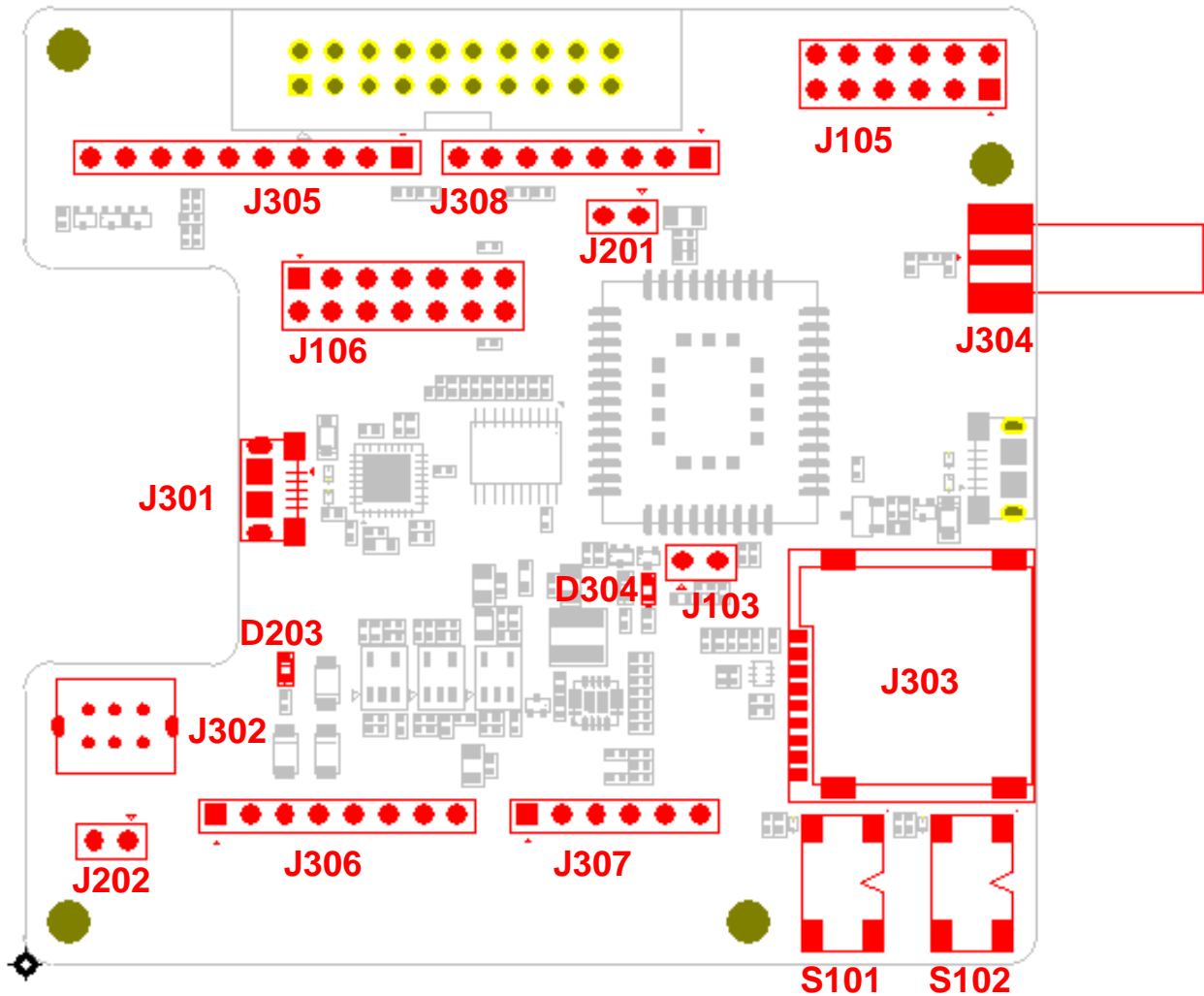

Figure 2: Interface Distribution Diagram of BC65-TE-B

The table below lists the interfaces of BC65-TE-B with descriptions.

Table 2: Interfaces of BC65-TE-B

Interface	Designator	Description
Power Supply Interfaces	J301	USB power supply interface
	J306	Arduino power supply interface

	J202	External power supply interface
USB-UART Interface	J301	Supports two UART ports
USIM Interface	J303	Micro USIM card connector
Arduino Interfaces	J305, J306, J307, J308	Standard Arduino interfaces
RF Antenna Interface	J304	RF SMA connector
UART Switch	J302	Selects the communication object of BC65's main UART: "MAIN UART TO USB" or "MAIN UART TO MCU"
RESET Button	S102	Resets the BC65 module
PWRKEY Button	S101	Powers on the BC65 module
LED Indicator	D203	Indicates the power status
LED Indicator	D304	Indicates the network status
Test Points	J103, J105, J106, J201	Tests the basic functionalities of the BC65 module

2.4. Arduino Interface Definition

The following figure shows the Arduino interface definition of BC65-TE-B.

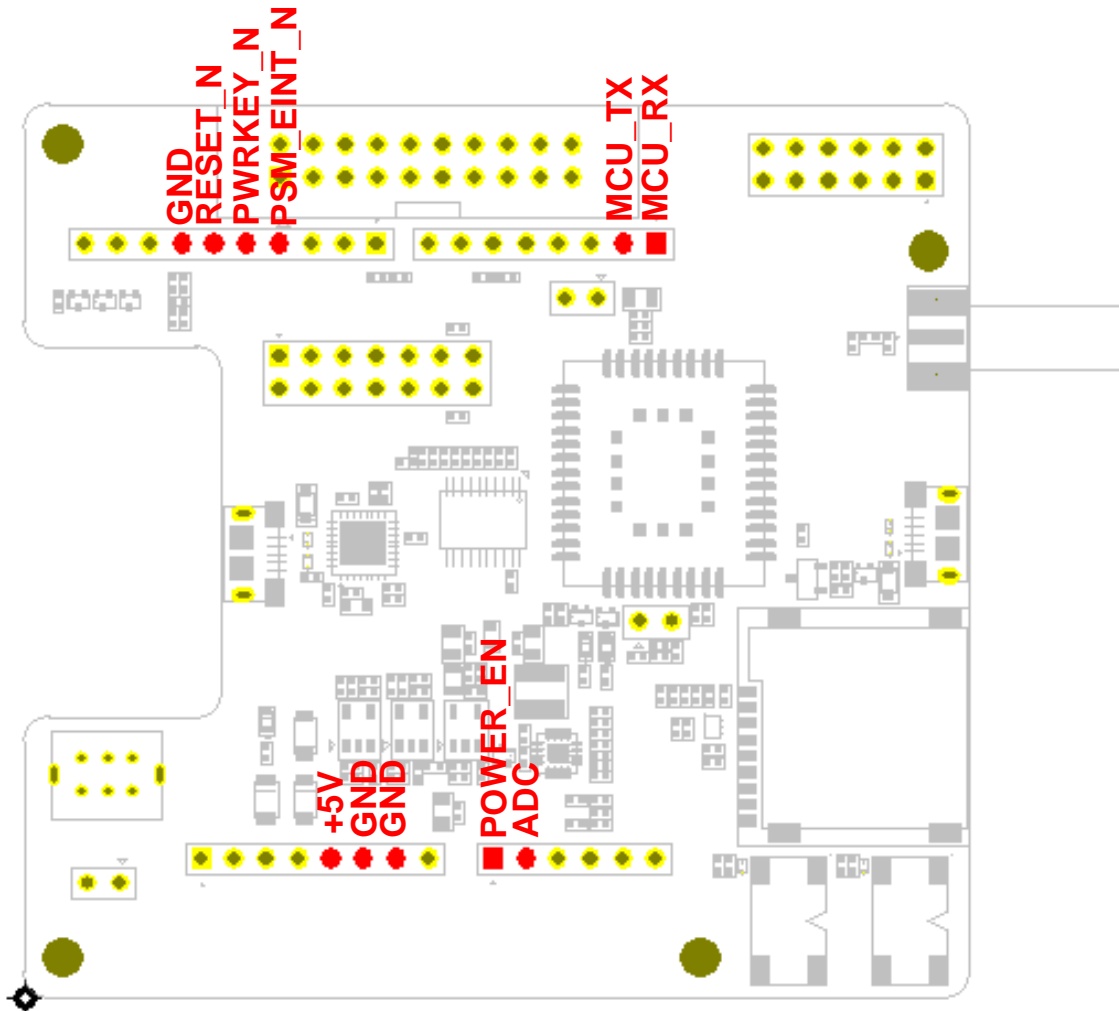

Figure 3: Arduino Interface Definition

3 Operation Procedures

This chapter mainly illustrates the operation procedures of BC65-TE-B. You can use BC65-TE-B alone to upgrade firmware and debug BC65-based NB-IoT applications. You can also use it together with an STM32 Nucleo-64 development board via the Arduino interface to develop STM32-based NB-IoT applications. This chapter describes the two operation procedures for using BC65-TE-B.

3.1. Operation Procedure with Single Board

This section elaborates the operation procedures of using the BC65-TE-B alone.

3.1.1. Interface Diagram

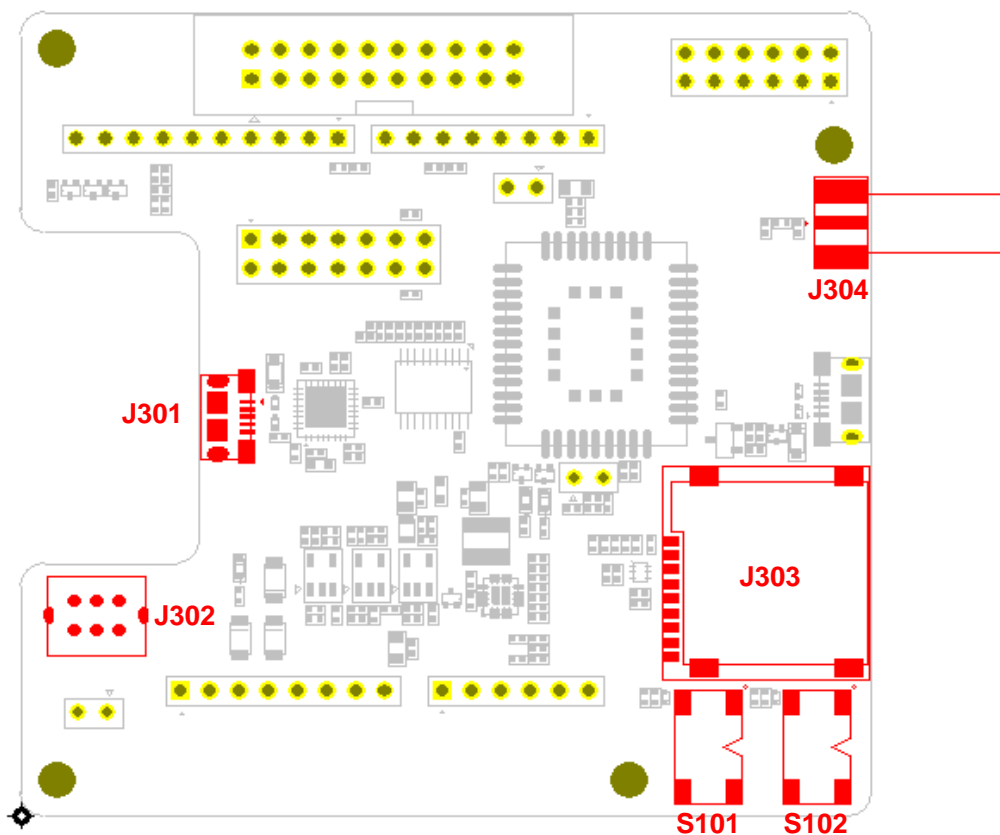

Figure 4: Interface Diagram of Using BC65-TE-B Alone

3.1.2. Operation Procedure

1. Install a USB-UART driver. You can download it from the following address:
<https://www.maxlinear.com/product/interface/uarts/usb-uarts/xr21v1414>.
2. Insert a Micro USIM card into J303, please choose an appropriate USIM card according to different hardware versions of the BC65 module.
3. Connect a rod antenna with the SMA connector on J304 (RF antenna connector).
4. Switch J302 (UART Switch) to “MAIN UART TO USB” state.
5. Connect J301 to a PC via a Micro USB cable. When BC65-TE-B is connected to the computer, UART port information is shown on the “Device Manager” of the PC. Ch A is the Main Port and is used for AT command communication. Ch B is the Debug Port and is used for viewing logs and upgrading firmware. For details of port configuration, see **document [1]**.



Figure 5: UART Ports Displayed on PC

NOTE

In this procedure, you can use S101 to start the BC65 module and S102 to reset the module.

3.2. Operation Procedures with Multi-boards

This section elaborates the operation procedures of using the BC65-TE-B in conjunction with an STM32 Nucleo-64 development board.

3.2.1. Interface Diagram

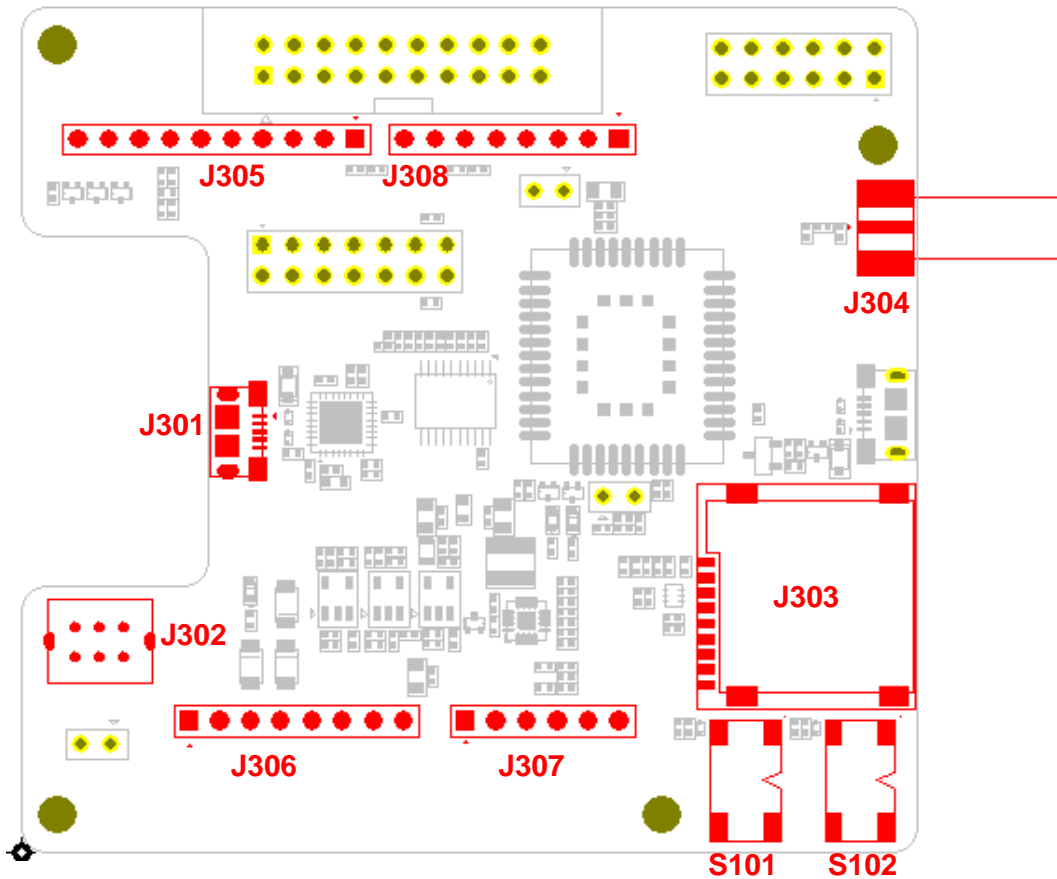

Figure 6: Interface Diagram of Using Multi-boards

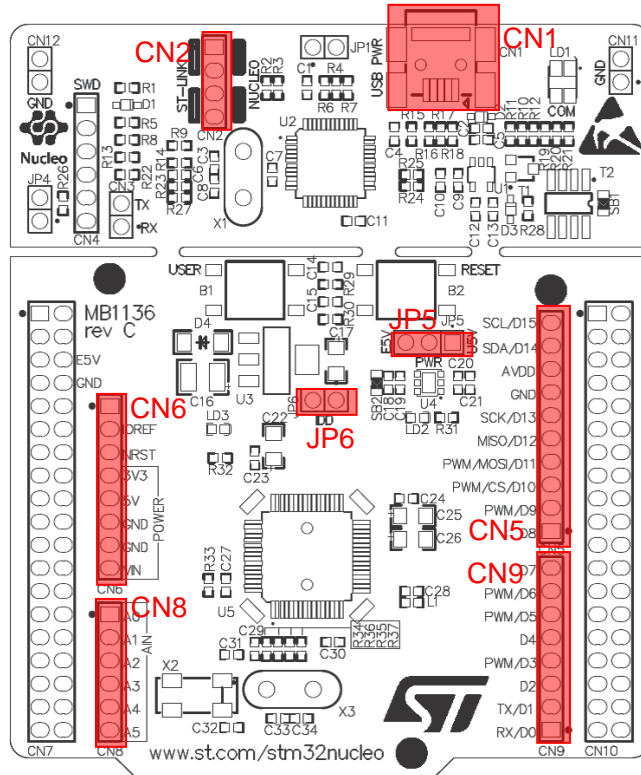

Figure 7: STM32 Nucleo-64 Interface Diagram (Top View)

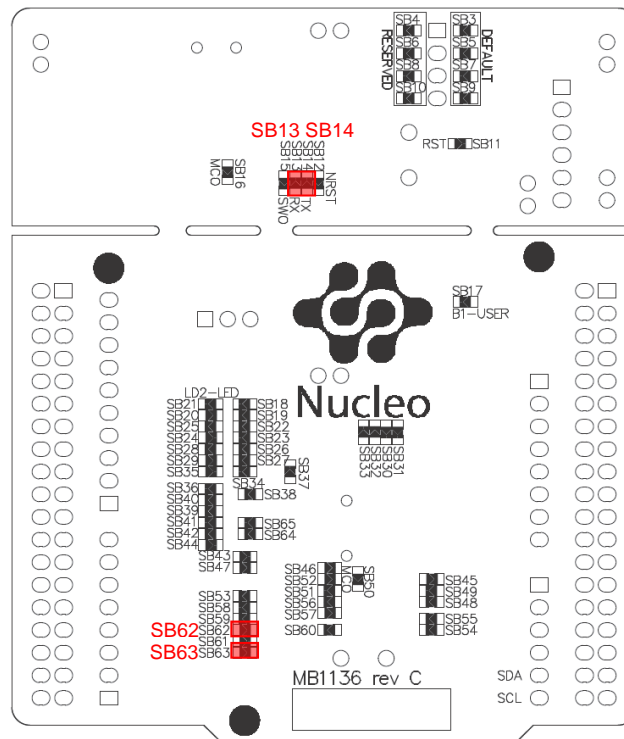

Figure 8: STM32 Nucleo-64 Modification Diagram (Bottom View)

3.2.2. Operation Procedure

1. Install a driver for the STM32 Nucleo-64 board. You can download it from the following address:
http://www.st.com/content/st_com/en/products/evaluation-tools/product-evaluation-tools/mcu-eval-to-ols/stm32-mcu-eval-tools/stm32-mcu-nucleo/nucleo-l476rg.html.
2. Install a USB-UART driver. You can download it from the following address:
<https://www.maxlinear.com/product/interface/uarts/usb-uarts/xr21v1414>.
3. Remove the two 0-ohm resistors of SB13 and SB14 by soldering iron, and solder them onto SB62 and SB63 respectively.
4. Short-circuit pin 1 and pin 2 of CN2, pin 3 and pin 4 of CN2, pin 1 and pin 2 of JP5 and pin 1 and pin 2 of JP6 respectively.
5. Insert Micro USIM card into J303, and choose an appropriate USIM card according to hardware versions of BC65 module.
6. Connect rod antenna with SMA connector on J304(RF antenna connector).
7. Switch J302 (UART Switch) to the “MAIN UART TO MCU” state.
8. Connect the Arduino interfaces to the STM32 Nucleo-64 board by connecting J305, J306, J307 and J308 of BC65-TE-B to CN5, CN6, CN8 and CN9 respectively.
9. Connect CN1 of the STM32 Nucleo-64 board to a PC via a Mini USB cable. When the BC65 module is powered on, device information is shown on the “Device Manager” of the PC.

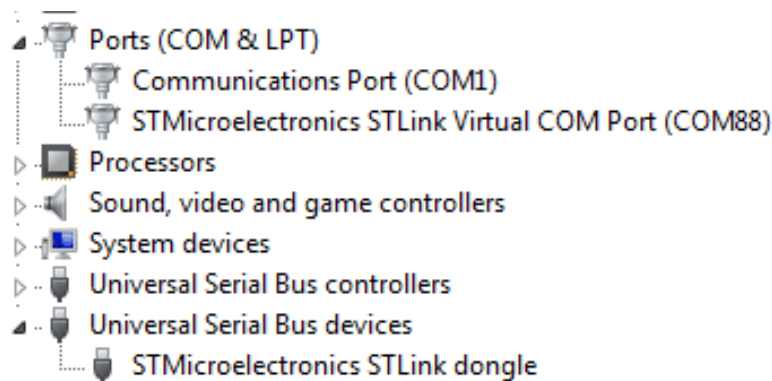

Figure 9: ST-LINK Interface Displayed on PC

3.2.3. Description of Pin Connection

The table below shows the pin connection between BC65-TE-B and STM32-L476RG MCU.

Table 3: Pin Connection between BC65-TE-B and STM32-L476RG MCU

No.	MCU (Morpho)	Arduino	BC65-TE-B	Remark	
1	PA2	D1	CN9-2	MCU_TX	Connects to the RX of the main UART

2	PA3	D0	CN9-1	MCU_RX	Connects to the TX of the main UART
3	PA7	D11	CN5-4	PSM_EINT_N	Externally interrupts the module from Deep Sleep
4	PA6	D12	CN5-5	PWRKEY_N	Active high
5	PA5	D13	CN5-6	RESET_N	Active high
6	PA1	A1	CN8-2	ADC	Analog to Digital
7	PA0	A0	CN8-1	POWER_EN	Enables DC-DC
8	+5V	+5V	CN6-5	+5V	5.0 V power supply
9	GND	GND	CN5-7, CN6-6, CN6-7	GND	Ground

The following figure shows the pin connection between BC65-TE-B and STM32-L476RG MCU.

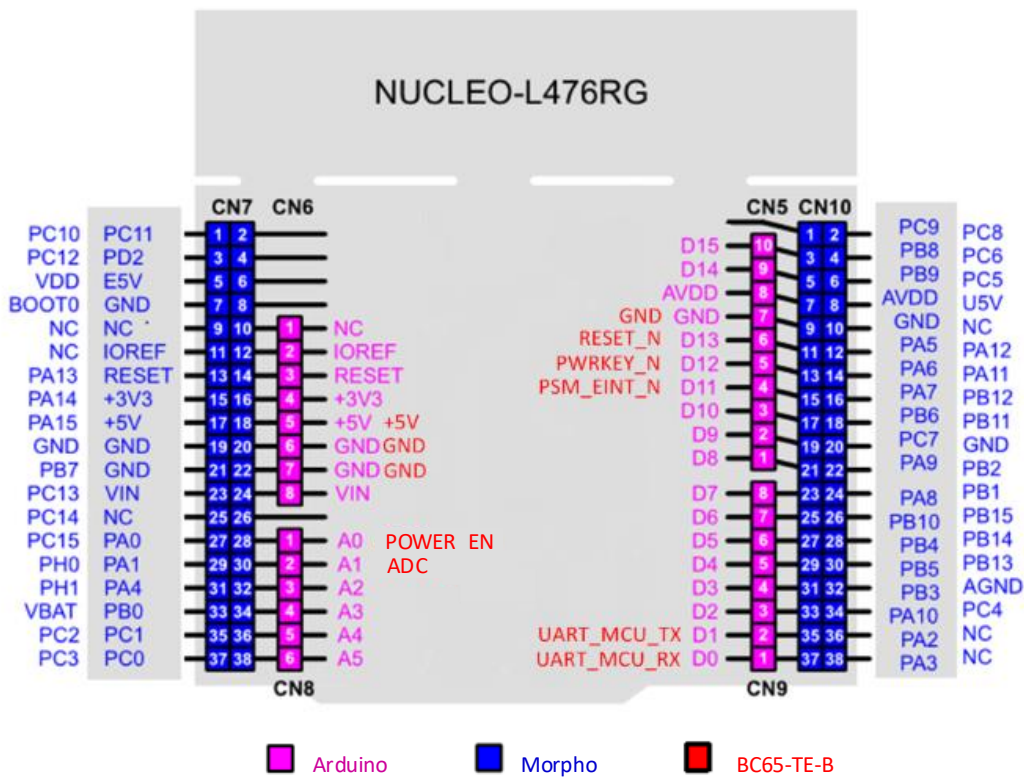

Figure 10: Pin Connection between BC65-TE-B and STM32-L476RG MCU

4 Electrical Performance & Reliability

4.1. Absolute Maximum Ratings

Absolute maximum ratings for power supply and voltage on digital and analog pins of the BC65 module are listed in the following table.

Table 4: Absolute Maximum Ratings

Parameter	Min.	Max.	Unit
V _{BAT}	0	+4.35	V
Voltage at Digital Pins	TBD	TBD	V
Voltage at Analog Pins	TBD	TBD	V
Voltage at Digital/Analog Pins in Power Down Mode	TBD	TBD	V

4.2. Operating and Storage Temperatures

The operating and storage temperatures are listed in the following table.

Table 5: Operating and Storage Temperatures

Parameter	Min.	Typ.	Max.	Unit
Operating Temperature ¹⁾	-25	+25	+75	°C
Extended Temperature ²⁾	-40		+85	°C
Storage Temperature	-40		+90	°C

NOTES

- 1) Within the operation temperature range, the module meets 3GPP specifications.
- 2) Within the extended temperature range, the module remains the ability to establish and maintain functions such as SMS, data transmission, without any unrecoverable malfunction. Radio spectrum and radio network will not be influenced, while one or more specifications, such as P_{out} , may undergo a reduction in value, exceeding the specified tolerances of 3GPP. When the temperature returns to the normal operating temperature level, the module will meet 3GPP specifications again.

5 Mechanical Dimensions

This chapter describes the mechanical dimensions of BC65-TE-B. All dimensions are measured in mm. The tolerances for dimensions are ± 0.15 mm.

5.1. Mechanical Dimensions of BC65-TE-B

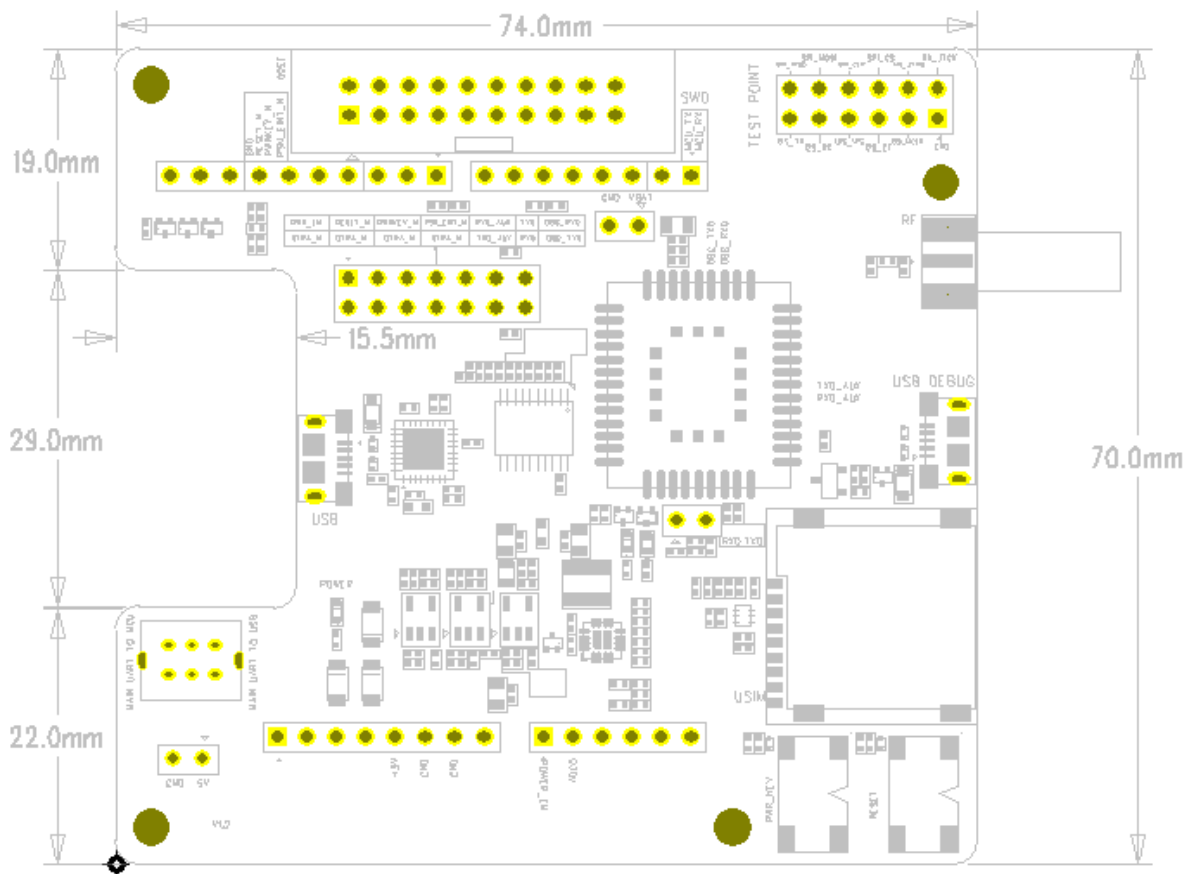

Figure 11: Dimensions of BC65-TE-B (Top View)

5.2. Top and Bottom Views of BC65-TE-B

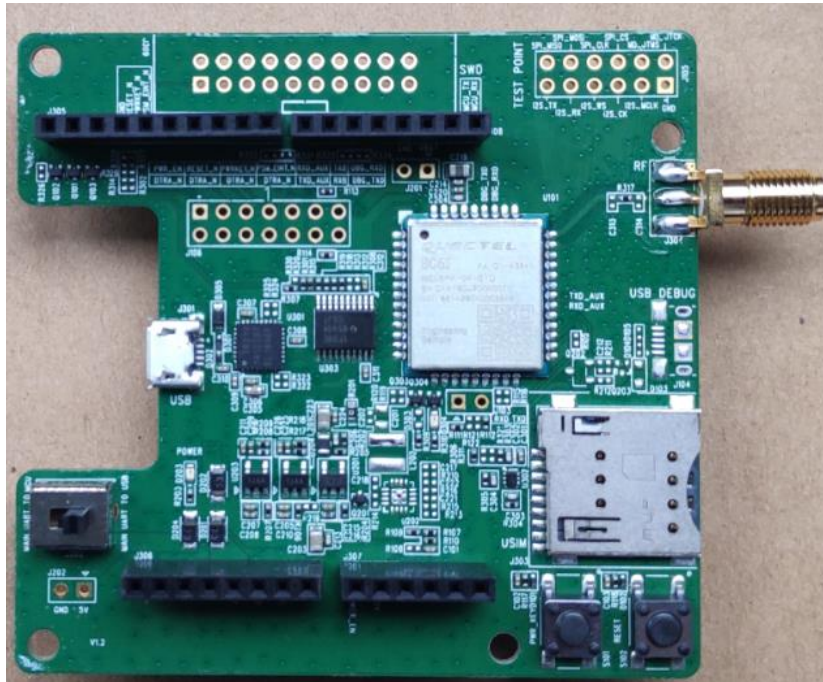

Figure 12: Top View of the BC65-TE-B

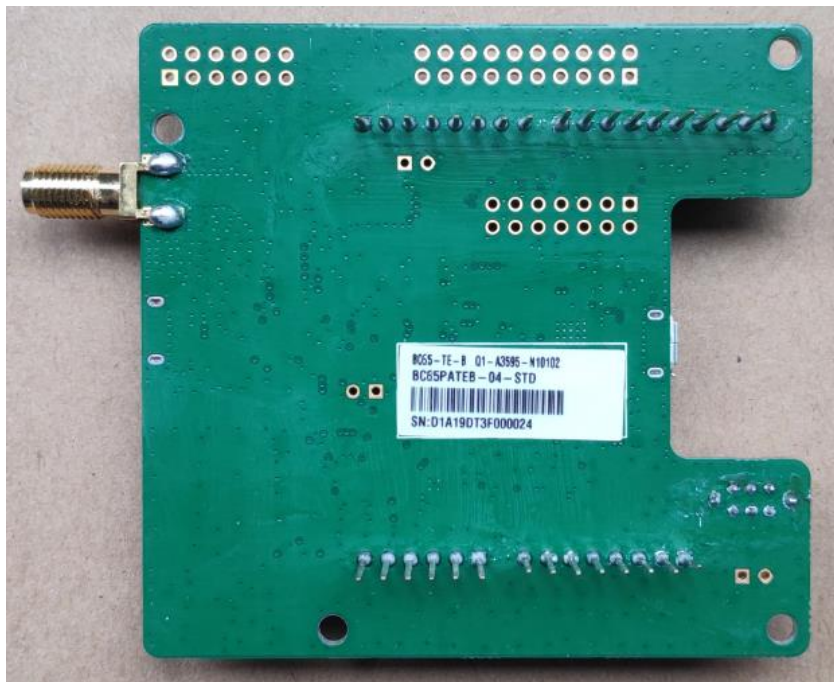

Figure 13: Bottom View of the BC65-TE-B

6 BC65-TE-B Kit and Accessories

6.1. BC65-TE-B Kit



Figure 14: BC65-TE-B Kit Assembly

6.2. BC65-TE-B Kit Accessories



Figure 15: BC65-TE-B and the Accessories

Table 6: Accessories List

Item	Description	Quantity
Antenna	NB-IoT antenna with SMA connector	1
Cable	Micro USB cable	1
Instruction Sheet	Describes BC65-TE-B connection, details of accessories, etc.	1

7 Appendix A References

Table 7: Related Document

No.	Document Name	Remark
[1]	Quectel_BC65_Hardware_Design	BC65 hardware design

Table 8: Terms and Abbreviations

Abbreviation	Description
3GPP	3rd Generation Partnership Project
3GPP Rel-13	3GPP Release 13
3GPP Rel-14	3GPP Release 14
bps	Bit(s) Per Second
dBm	Decibel Relative to One Milliwatt
DFOTA	Delta Firmware Upgrade Over-the-air
LED	Light Emitting Diode
LPWA	Low-Power Wide-Area
MCU	Microcontroller Unit
NB-IoT	Narrow Band Internet of Things
PC	Personal Computer
RF	Radio Frequency
SMA	SubMiniature Version A
SMS	Short Message Service
TBD	To Be Determined

UART	Universal Asynchronous Receiver & Transmitter
USB	Universal Serial Bus
USIM	Universal Subscriber Identification Module
