

CTP FPC

PIN NO.	SYMBOL
1	SDA
2	SCL
3	RST
4	INT
5	VDDT
6	VSS

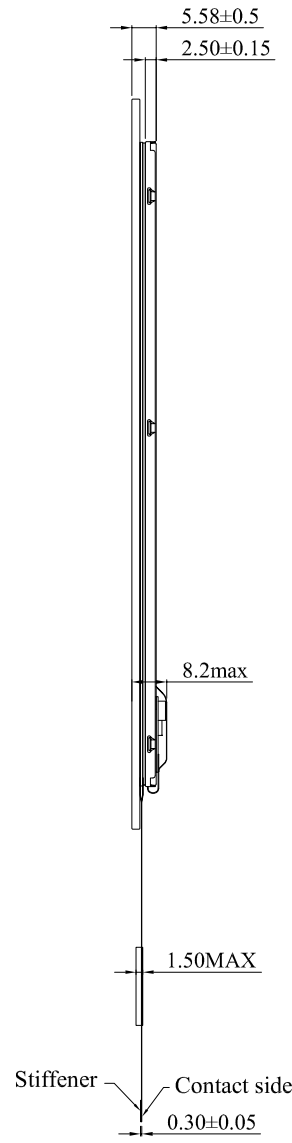
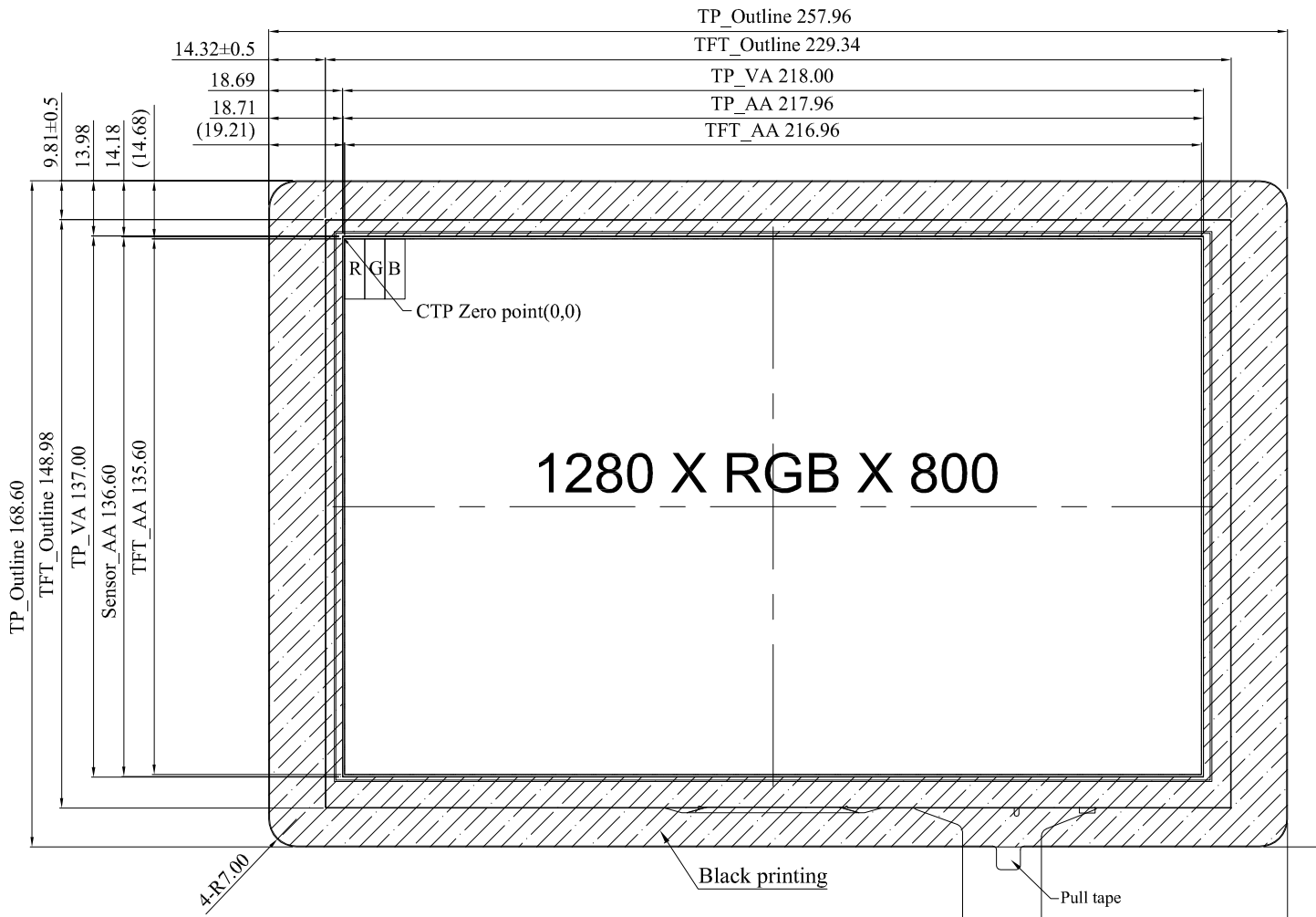

The non-specified tolerance of dimension is ±0.3mm.

SCALE: 1/1	UNIT: mm	華凌光電股份有限公司 WINSTAR DISPLAY CO.
REV: 0	PAGE: 1/2	
APPROVE	梁榮智06/09/2021	MODEL WF101KTYAPLNG0#
CHECK	蔡宜珍06/09/2021	TITLE TFT MODULE
DRAW	李楠 06/09/2021	DWG NO. T-100632

1	Lcd Type	TFT
2	Viewing Angle	80/80/80/80
3	Surface	Glare
4	Screen size	10.1"(diagonal)
5	Display format	1280 x RGB x 800
6	Operating Temperature	-20°C ~70°C
7	Storage Temperature	-30°C ~80°C
8	Active area	216.96(H) x 135.6(V) mm
9	Pixel pitch	0.1695(H) x 0.1695(V) mm
10	Color arrangement	RGB-STRIFE
11	Brightness	300min. cd/m2
12	CTP Driver IC	GT928 or equivalent
13	CTP Resolution	1280*800

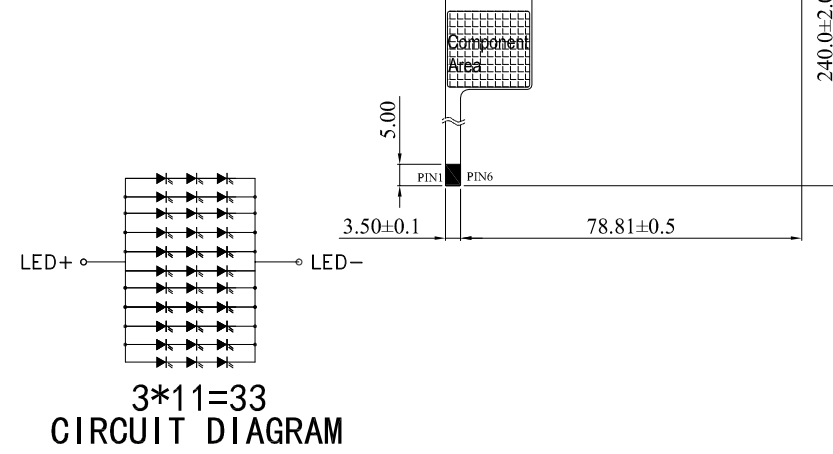

CN1			
PIN NO	SYMBOL	PIN NO	SYMBOL
1	NC	21	Rxin3+
2	VCC	22	GND
3	VCC	23	NC
4	NC	24	NC
5	NC	25	GND
6	NC	26	NC
7	GND	27	NC
8	Rxin0-	28	NC
9	Rxin0+	29	AVDD
10	GND	30	GND
11	Rxin1-	31	LED-
12	Rxin1+	32	LED-
13	GND	33	NC
14	Rxin2-	34	NC
15	Rxin2+	35	VGL
16	GND	36	NC
17	RxCLK-	37	NC
18	RxCLK+	38	VGH
19	GND	39	LED+
20	Rxin3-	40	LED+

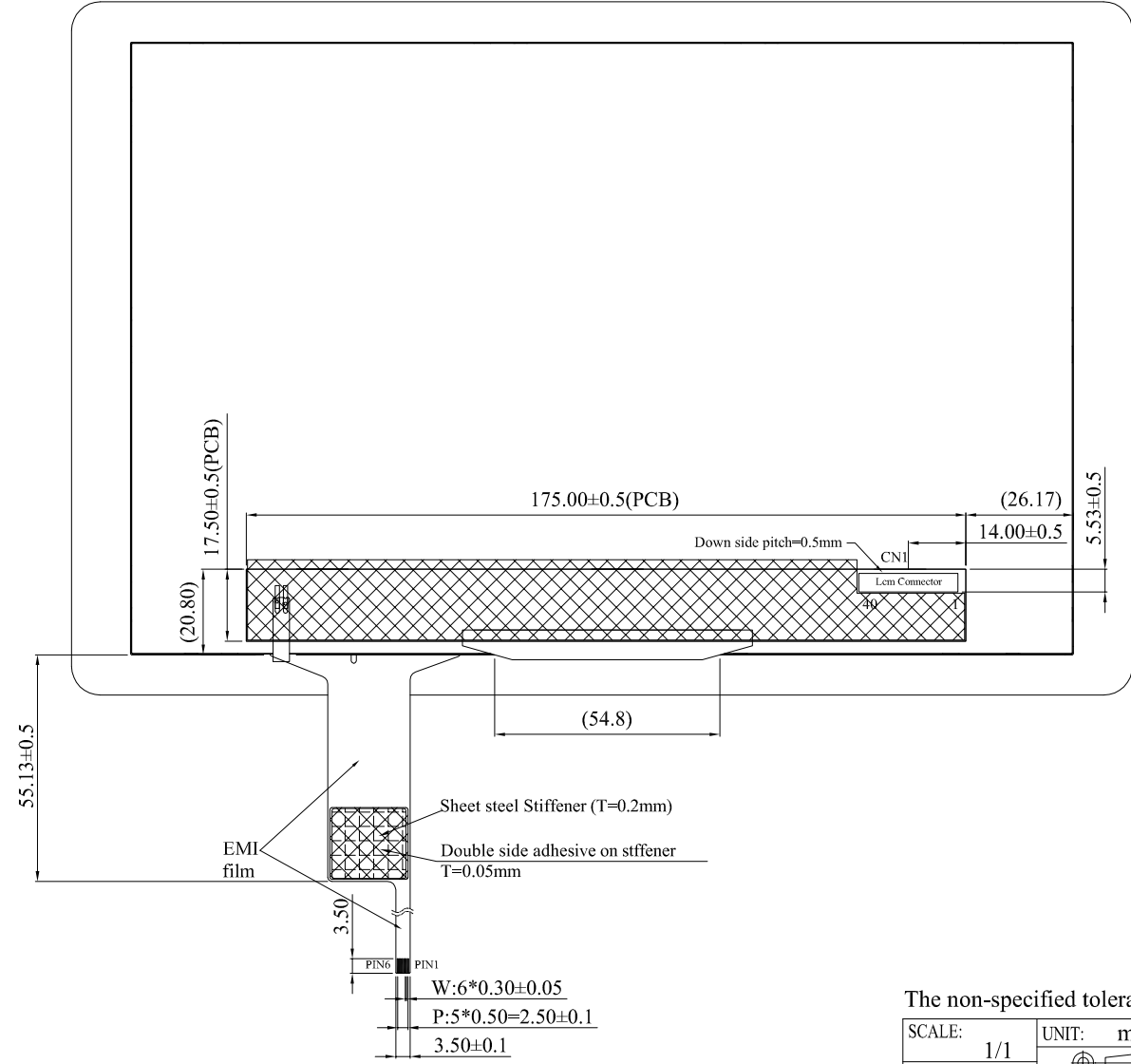

The non-specified tolerance of dimension is ±0.3mm.

SCALE:	1/1	UNIT:	mm	華凌光電股份有限公司 WINSTAR DISPLAY CO.
REV:	0	PAGE:	2/2	
APPROVE	梁榮智06/09/2021	MODEL	WF101KTYAPLNG0#	
CHECK	蔡宜珍06/09/2021	TITLE	TFT MODULE	
DRAW	李楠 06/09/2021	DWG NO.	T-100632	