



WINSTAR Display Co.,Ltd.
華凌光電股份有限公司



Winstar Display Co., LTD

華凌光電股份有限公司

WEB: <http://www.winstar.com.tw> E-mail: sales@winstar.com.tw



SPECIFICATION

CUSTOMER : _____

MODULE NO.: WF123ASWGYLNGO#

<p>APPROVED BY: (FOR CUSTOMER USE ONLY)</p>	<p>PCB VERSION: _____ DATA: _____</p>
--	---

SALES BY	APPROVED BY	CHECKED BY	PREPARED BY
			葉虹蘭
ISSUED DATE: 2017/04/25			

RECORDS OF REVISION

DOC. FIRST ISSUE

VERSION	DATE	REVISED PAGE NO.	SUMMARY
0	2016/10/03		First issue
A	2017/04/25		Modify Contour Drawing.

Contents

- 1.Module Classification Information
- 2.Summary
- 3.General Specification
- 4.Absolute Maximum Ratings
- 5.Electrical Characteristics
- 6.AC Electrical Characteristics
- 7.Optical Characteristics
- 8.Interface
- 9.Reliability
- 10.Contour Drawing
- 11.Other

1.Module Classification Information

W F 123 A S W G Y L N G 0 #
 ① ② ③ ④ ⑤ ⑥ ⑦ ⑧ ⑨ ⑩ ⑪ ⑫ ⑬

①	Brand : WINSTAR DISPLAY CORPORATION											
②	Display Type : F→TFT Type, J→Custom TFT											
③	Display Size : 12.3” TFT											
④	Model serials no.											
⑤	Backlight Type :	F→CCFL, White S→LED, High Light White					T→LED, White Z→Nichia LED, White					
⑥	LCD Polarize Type/ Temperature range/ Gray Scale Inversion Direction	A→Transmissive, N.T, IPS TFT C→Transmissive, N. T, 6:00 ; F→Transmissive, N.T,12:00 ; I→Transmissive, W. T, 6:00 K→Transflective, W.T,12:00 L→Transmissive, W.T,12:00 N→Transmissive, Super W.T, 6:00					Q→Transmissive, Super W.T, 12:00 R→Transmissive, Super W.T, O-TFT V→Transmissive, Super W.T, VA TFT X→Transmissive, W.T, VA TFT Y→Transmissive, W.T, IPS TFT Z→Transmissive, W.T, O-TFT					
⑦	A : TFT LCD B : TFT+FR+CONTROL BOARD C : TFT+FR+A/D BOARD D : TFT+FR+A/D BOARD+CONTROL BOARD E : TFT+FR+POWER BOARD					F : TFT+CONTROL BOARD G : TFT+FR H : TFT+D/V BOARD I : TFT+FR+D/V BOARD J : TFT+POWER BD						
⑧	Resolution:											
	A	128160	B	320234	C	320240	D	480234	E	480272	F	640480
	G	800480	H	1024600	I	320480	J	240320	K	800600	L	240400
	M	1024768	N	128128	P	1280800	Q	480800	R	640320	S	480128
	T	800320	U	8001280	V	176220	W	1280398	X	1024250	Y	1920720
	Z	800200	2	1024324	3	7201280						
⑨	D: Digital L : LVDS M:MIPI											
⑩	Interface : N:without control board A:8Bit B:16Bit H: HDMI I:I2C Interface R:RS232 S:SPI Interface U:USB											
⑪	TS : N : Without TS T : resistive touch panel C : capacitive touch panel (G-F-F) G : capacitive touch panel(G-G)											
⑫	Version											
⑬	Special Code	#:Fit in with ROHS directive regulations										

2.Summary

TFT 12.3" (24 : 9) is a IPS(In-Plane Switching) color active matrix TFT liquid crystal display that use amorphous silicon TFT as switching devices. This module is a composed of a TFT_LCD module, It is usually designed for industrial application and this module follows RoHs.

3. General Specifications

Item	Dimension	Unit
Size	12.3	inch
Pixel Number	1920 x R.G.B. x 720	pixel
Module dimension	313.4 x 135.86 x10.6	mm
Active Area	292.32 (H) x 109.62 (V)	mm
Pixel Pitch	0.1523(H) x 0.1523(V)	mm
LCD type	TFT, Normally Black, Transmissive	
Gray Scale Inversion Direction	ALL	
Backlight Type	LED ,Normally White	
Weight of Module(g)	768g	
With /Without TP	With CTP	
Surface	Glare	

*Color tone slight changed by temperature and driving voltage.

4. Absolute Maximum Ratings

Item	Symbol	Min	Typ	Max	Unit
Operating Temperature	TOP	-30	—	+85	°C
Storage Temperature	TST	-40	—	+95	°C

Note: Device is subject to be damaged permanently if stresses beyond those absolute maximum ratings listed above

1. Temp. $\leq 60^{\circ}\text{C}$, 90% RH MAX. Temp. $> 60^{\circ}\text{C}$, Absolute humidity shall be less than 90% RH at 60°C

5. Electrical Characteristics

5.1. Driving TFT LCD Panel

Item	Symbol	MIN	TYP	MAX	Unit
Power voltage	VD	3.0	3.3	3.6	V
	IVDD	-	1.1	1.4	A
Operating Temperature	TOP	-30	85	°C	-
Storage Temperature	TST	-40	95	°C	-

Note 1 : Test pattern is the following picture (white pattern)

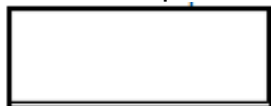

5.2. Signal DC Electrical Characteristics

Parameter	Symbol	MIN	TYP	MAX	Unit	Notes
Differential input high threshold	R_{XVTH}	-	-	200	mV	$R_{XVCM}=1.2V$
Differential input low threshold	R_{XVTL}	-200	-	-	mV	$R_{XVCM}=1.2V$
Input voltage range (singled-end)	R_{XVIN}	0.7	-	1.6	V	
Input differential voltage	$ V_{ID} $	200	-	600	mV	
Differential input Common Mode voltage	R_{XVCM}	1.0	1.2	1.3	V	

Single-end Signal

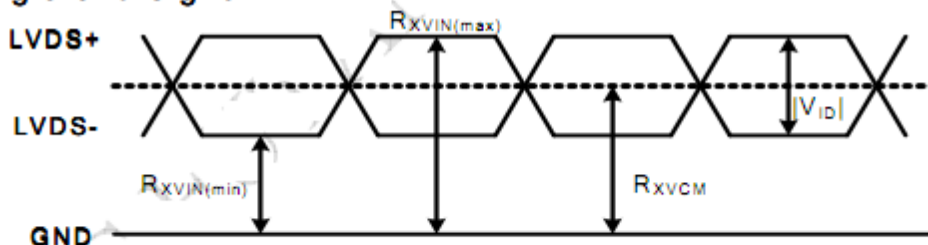

Differential Signal

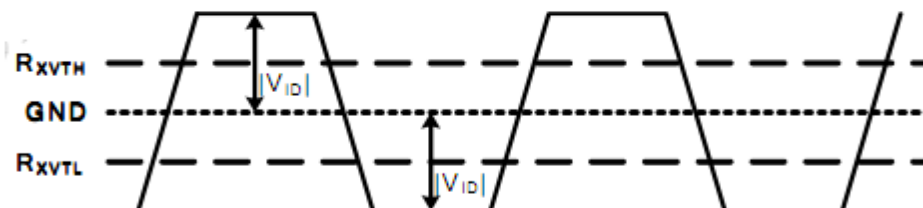

Fig. 1 LVDS DC characteristics diagram

BACKLIGHT UNIT

Item	Symbol	MIN	TYP	MAX	Unit	Remark
Forward Current	IF	-	480	520	mA	
Forward Voltage	VF	-	32	33	V	
Backlight Power consumption	WBL	-	15.36	17.16	W	
LED Lifetime	-	70000	-	-	Hrs	

Note 1: Each LED: IF =60 mA, VF =3.2V.

Note 2: Optical performance should be evaluated at Ta=25°C only.

Note 3: If LED is driven by high current, high ambient temperature & humidity condition. The life time of LED will be reduced. Operating life means brightness goes down to 50% initial brightness.

Typical operating life time is estimated data.

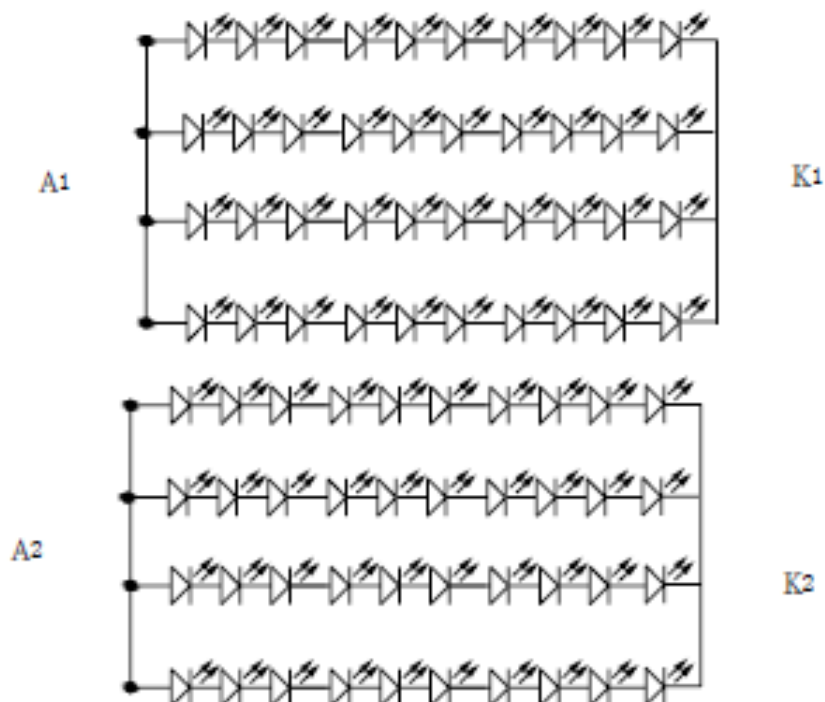

6.AC Electrical Characteristics

6.1. Differential signal AC characteristics

Parameter	Symbol	MIN	TYP	MAX	Unit	Notes
Clock frequency	RXVTH	44.7	47.5	61	MHz	
Input data skew margin	RXVTL	-	-	200	ps	Vid=200mV Rxvcm=1.2v Note1
Clock strobe width	RXVIN	1200	-	-	ps	
Clock high time	VID	-	$4/(7 \cdot R_{XFCLK})$	-	ns	
Clock low time	RXVCM	-	$3/(7 \cdot R_{XFCLK})$	-	ns	

Note1. For the Data Skew Margin, "Input Signal Skew + Input Signal Jitter" must be smaller than TRSKM.

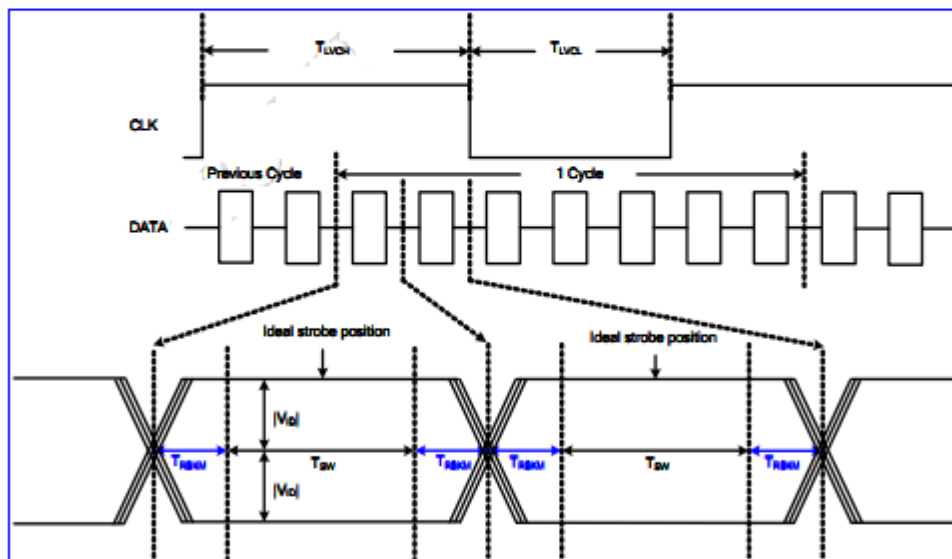
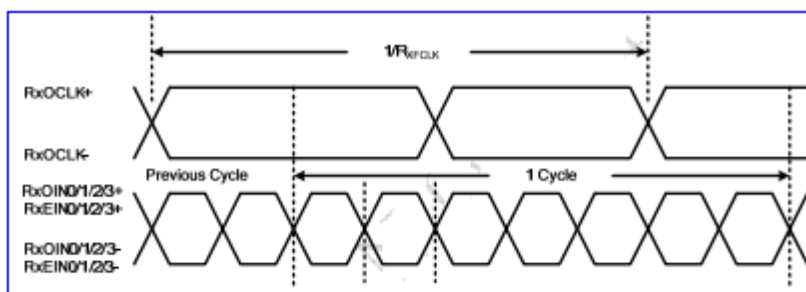

ALL RIGHTS STRICTLY RESERVED, ANY PORTION OF THIS PAPER SHALL NOT BE REPRODUCED COPIED, OR TRANSFORMED TO ANY OTHER FORMS WITHOUT PERMISSION FROM AU OPTRONICS CORP.

Fig.1 Data skew margin Differential Input Data Format

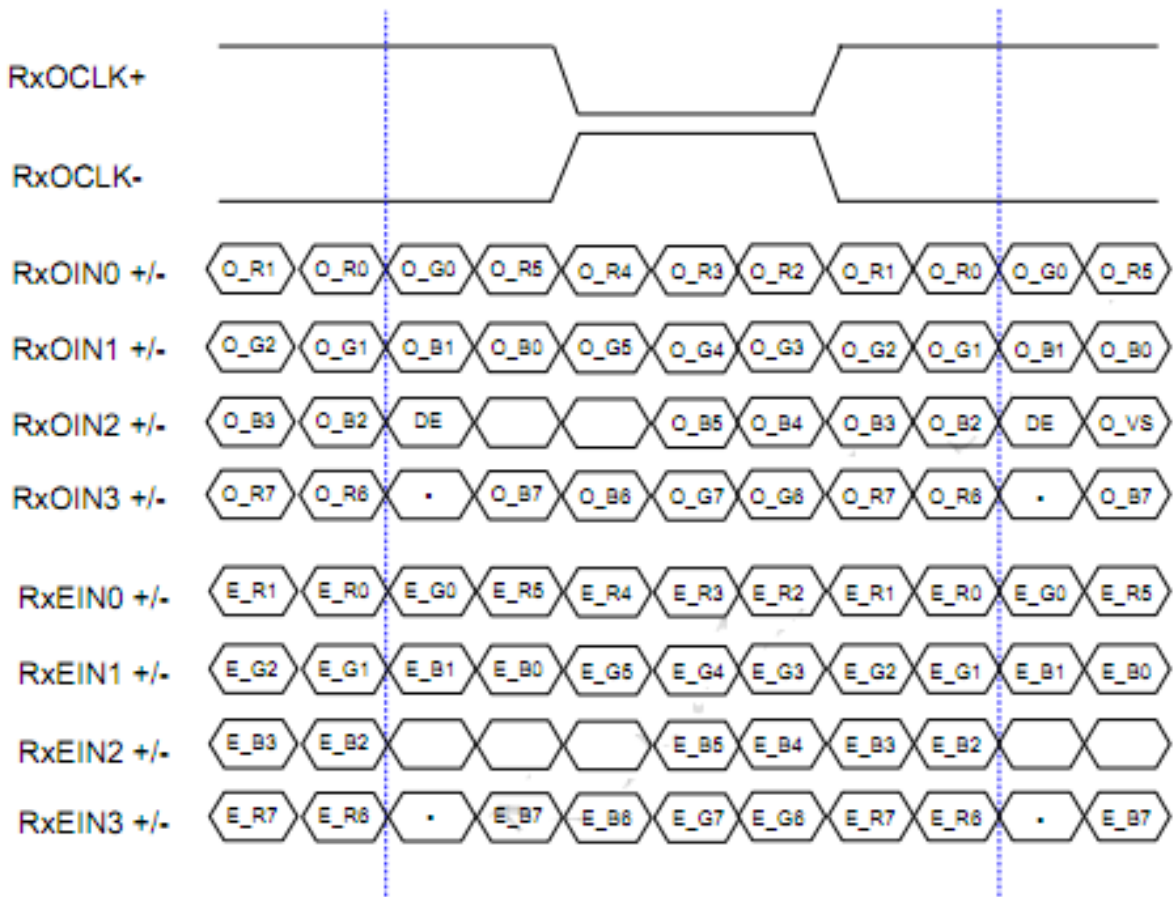

Fig . 1 LVDS input data VESA format

6.2. Timing Condition

a. DE Mode

Item	Symbol	Min	Typ.	Max	Unit	Remark
Clock frequency	F_{DCLK}	44.7	47.5	61	MHz	
Horizontal period area	T_H	1020	1040	1200	DCLK	
Horizontal display area	T_{HD}	960	960	960	DCLK	
Horizontal blanking area	T_{HB}	60	80	240	DCLK	
Vertical period area	T_V	730	760	840	T_H	
Vertical display area	T_{VD}	720	720	720	T_H	
Vertical blanking area	T_{VB}	10	40	120	T_H	
Frame rate	F_R	55	60	65	Hz	

b. Timing Diagram

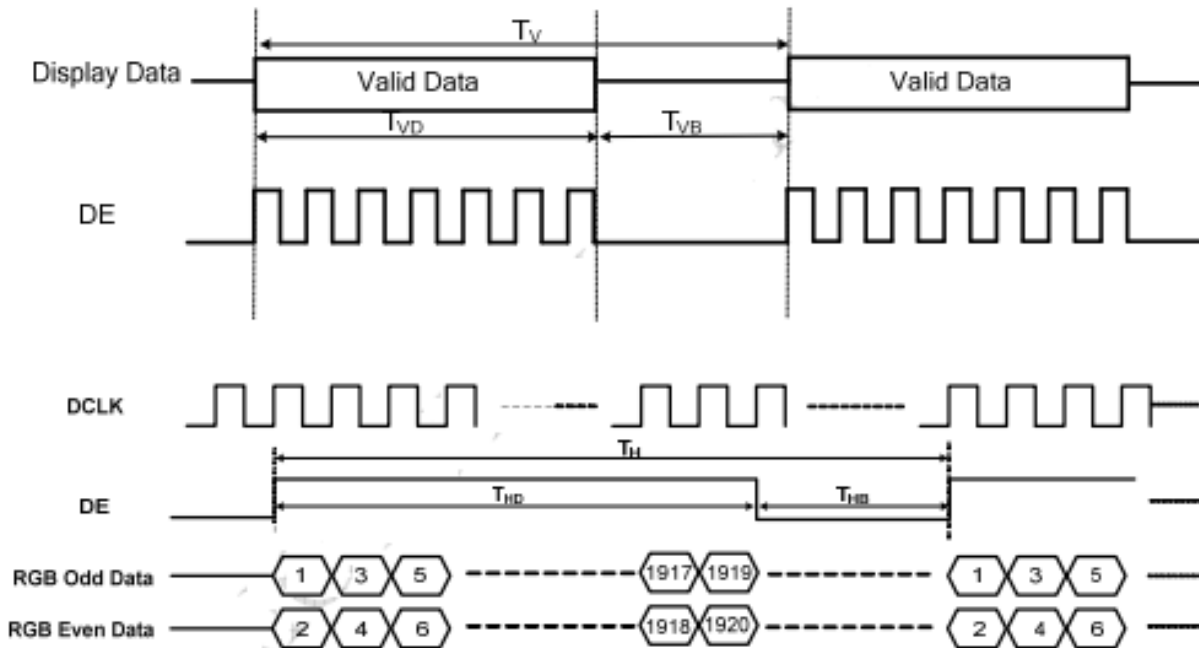

6.3. Feedback Signal Timing for Detected Function

Item	Symbol	Min	Typ	Max	Unit	Remark
STVD	V_{STVD-H}	VDD-0.3	--	VDD	V	$I_{STVD-H} = 200\mu A$
	V_{STVD-L}	GND	--	GND+0.3	V	$I_{STVD-L} = -200\mu A$
STVD frequency	F_{STVD}	55	60	65	HZ	
STVD period	T_{STVD}	15.4	16.6	18.2	ms	
STVD pulse width	T_{WSTVD}	19	21	23	us	

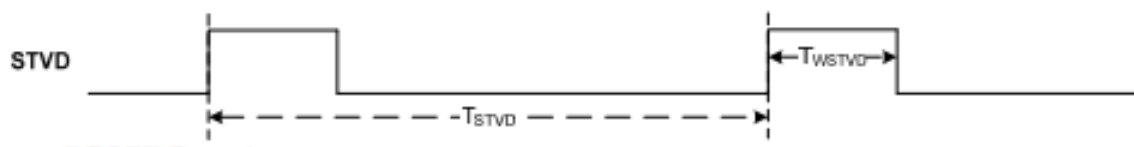

6.4. RESET Function

Item	Symbol	Min	Typ	Max	Unit	Remark
RESET	T1	1	--	20	ms	

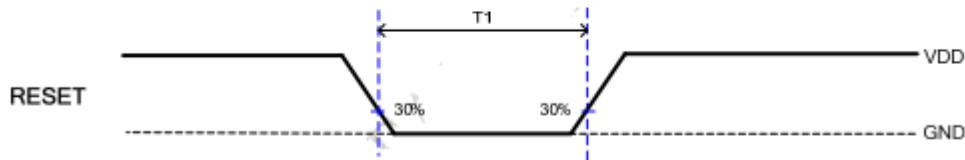

6.5. Power ON / OFF timing

The LCD adopts high voltage driver IC, so it could be permanently damaged under a wrong power on/off sequence. The suggested LCD power sequence is below:

a. Power on sequence

Parameter	Value			Unit
	Min.	Typ.	Max.	
T1	0.5	--	15	ms
T2	1	--	20	ms
T3	0	--	20	ms
T4	500	--	--	ms

Power on sequence

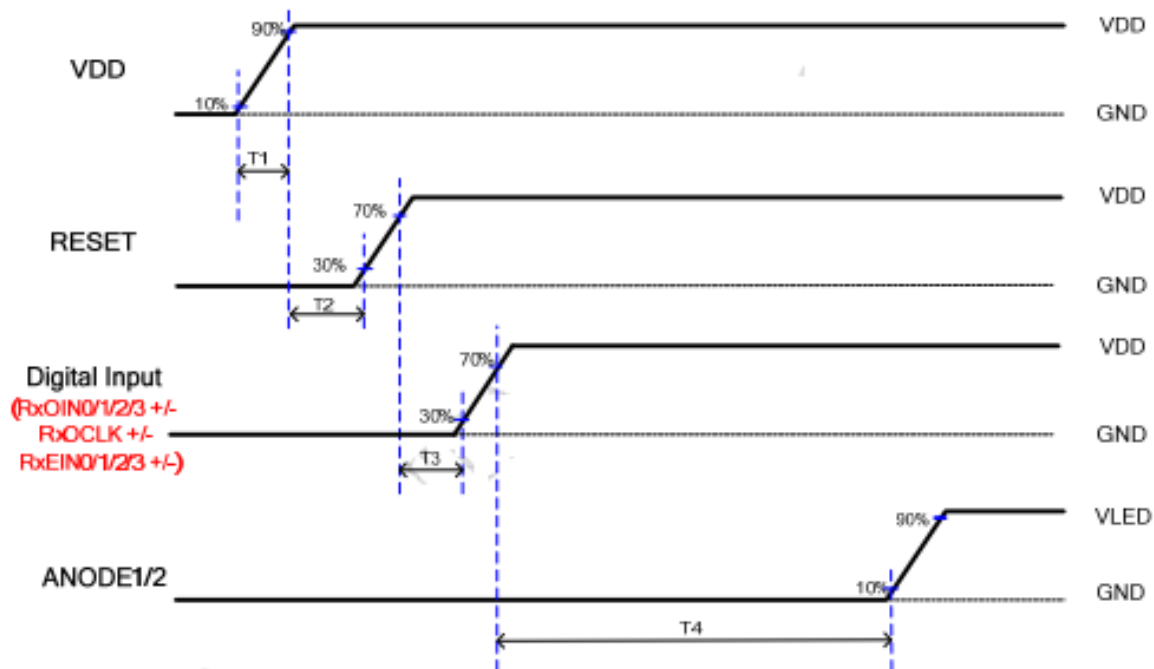

b. Power OFF sequence

Parameter	Value			Unit
	Min.	Typ.	Max.	
T1	200	--	--	ms
T2	0	--	20	ms
T3	1	--	20	ms

Power off sequence

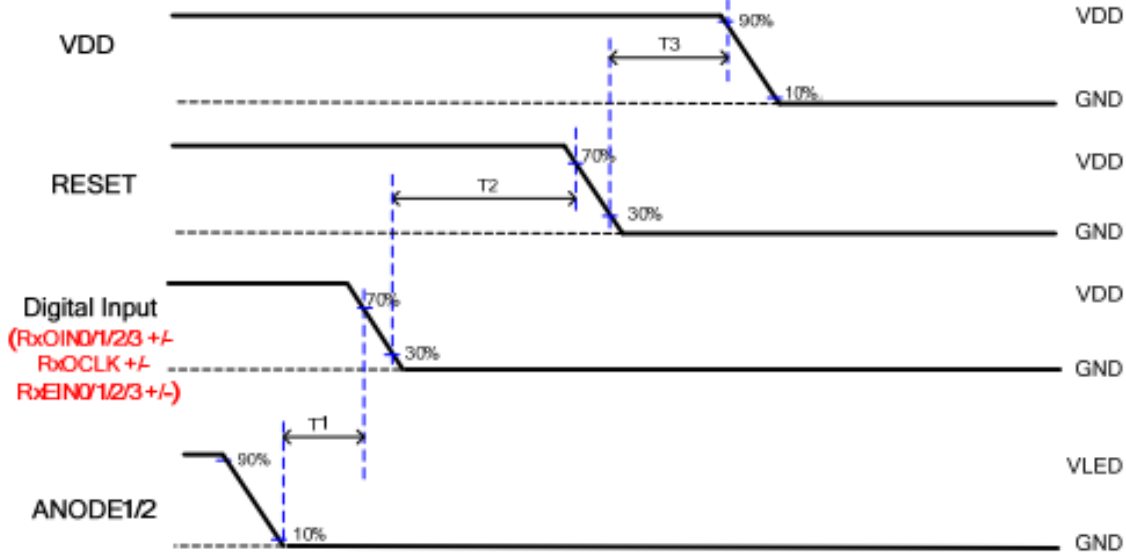

c. VDD ON/OFF

Parameter	Value			Unit
	Min.	Typ.	Max.	
T1	1000	--	-	ms

VDD ON / OFF

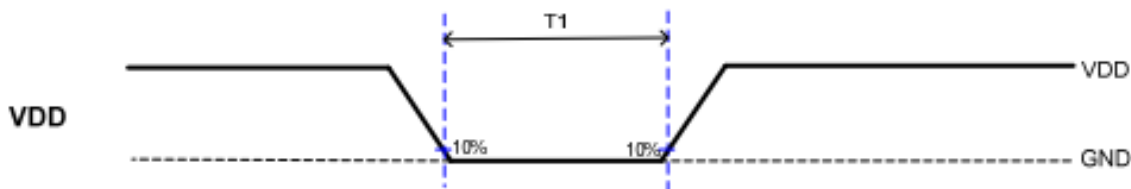

d. RESET ON/OFF

Parameter	Value			Unit
	Min.	Typ.	Max.	
T1	1000	--	-	ms

RESET ON / OFF

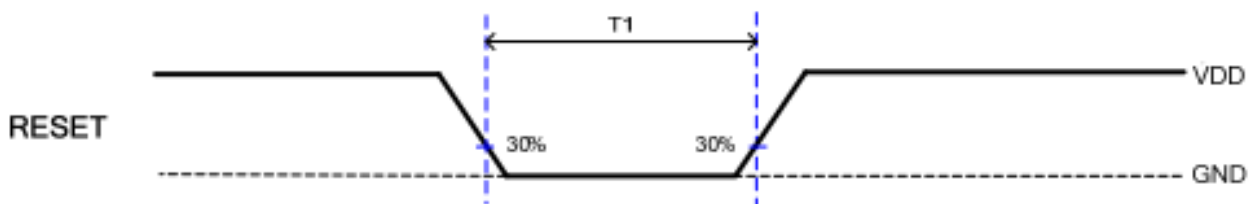

7. Optical Characteristics

Item	Symbol	Condition.	Min	Typ.	Max.	Unit	Remark
Response time	Tr	$\theta = 0^\circ \cdot \Phi = 0^\circ$	-	12	-	.ms	Note 3,5
	Tf		-	13	-	.ms	
Contrast ratio	CR	At optimized viewing angle	800	1000	-	-	Note 4,5
Color Chromaticity	White	$\theta = 0^\circ \cdot \Phi = 0$	0.26	0.31	0.36		Note 2,6,7
			0.28	0.33	0.38		
Viewing angle (Gray Scale Inversion Direction)	Hor.	ΘR	-	85	-	Deg.	Note 1
		ΘL	-	85	-		
	Ver.	ΦT	-	85	-		
		ΦB	-	85	-		
Brightness	-	-	750	800	-	cd/m ²	Center of display

Note 1: Definition of viewing angle range

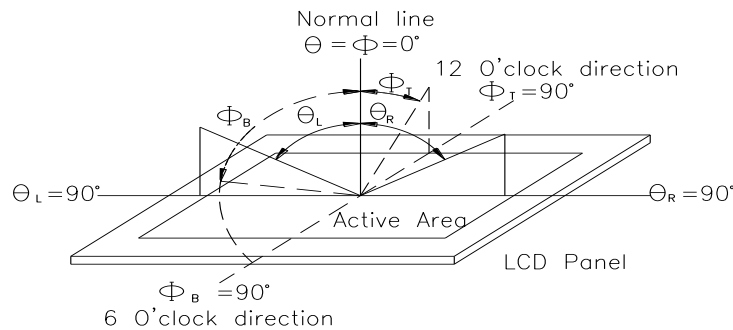

Fig.7.1. Definition of viewing angle

Note 2: Test equipment setup:

After stabilizing and leaving the panel alone at a driven temperature for 10 minutes, the measurement should be executed. Measurement should be executed in a stable, windless, and dark room. Optical specifications are measured by Topcon BM-7 or BM-5 luminance meter 1.0° field of view at a distance of 50cm and normal direction.

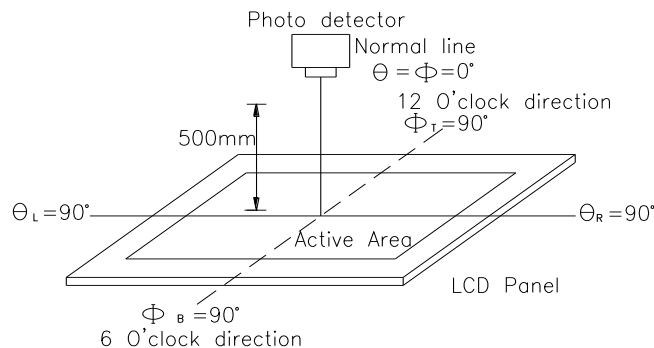
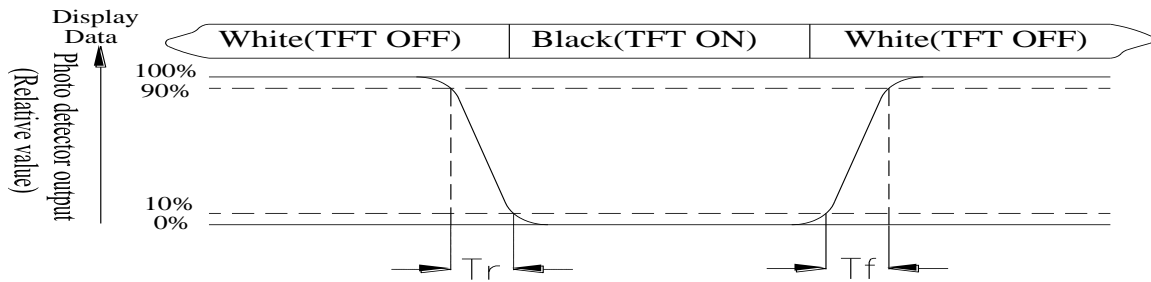

Fig. 7.2. Optical measurement system setup

Note 3: Definition of Response time:

The response time is defined as the LCD optical switching time interval between “White” state and “Black” state. Rise time, T_r , is the time between photo detector output intensity changed from 90% to 10%. And fall time, T_f , is the time between photo detector output intensity changed from 10% to 90%



Note 4: Definition of contrast ratio:

The contrast ratio is defined as the following expression.

$$\text{Contrast ratio (CR)} = \frac{\text{Luminance measured when LCD on the "White" state}}{\text{Luminance measured when LCD on the "Black" state}}$$

Note 5: White $V_i = V_{i50} \pm 1.5V$

Black $V_i = V_{i50} \pm 2.0V$

“±” means that the analog input signal swings in phase with VCOM signal.

“±” means that the analog input signal swings out of phase with VCOM signal.

The 100% transmission is defined as the transmission of LCD panel when all the input terminals of module are electrically opened.

Note 6: Definition of color chromaticity (CIE 1931)

Color coordinates measured at the center point of LCD

Note 7: Measured at the center area of the panel when all the input terminals of LCD panel are electrically opened.

8.Interface

8.1. TFT LCD MODULE

No	Symbol	Description
1	GND	Power ground
2	GND	Power ground
3	Rxoin0	-LVDS differential data input (Odd data)
4	Rxoin0+	+LVDS differential data input (Odd data)
5	GND	Power ground
6	Rxoin1-	-LVDS differential data input (Odd data)
7	Rxoin1+	+LVDS differential data input (Odd data)
8	GND	Power ground
9	Rxoin2-	-LVDS differential data input (Odd data)
10	Rxoin2+	+LVDS differential data input (Odd data)
11	GND	Power ground
12	RxoCLK-	-LVDS differential clock input (Odd clock)
13	RxoCLK+	+LVDS differential clock input (Odd clock)
14	GND	Power ground
15	Rxoin3-	-LVDS differential data input (Odd data)
16	Rxoin3+	+LVDS differential data input (Odd data)
17	GND	Power ground
18	Rxein0-	-LVDS differential data input (Even data)
19	Rxein0+	+LVDS differential data input (Even data)
20	GND	Power ground
21	Rxein1-	-LVDS differential data input (Even data)
22	Rxein1+	+LVDS differential data input (Even data)
23	GND	Power ground
24	Rxein2-	-LVDS differential data input (Even data)
25	Rxein2+	+LVDS differential data input (Even data)
26	GND	Power ground
27	Rxein3-	-LVDS differential data input (Even data)
28	Rxein3+	+LVDS differential data input (Even data)
29	GND	Power ground
30	STVD	Feedback signal
31	GND	Power ground
32	RESET	Global reset pin
33	GND	Power ground
34	VDD	Power input
35	VDD	Power input
36	VDD	Power input
37	VDD	Power input

38	VDD	Power input
39	GND	Power ground
40	GND	Power ground

I: Digital signal input, G:GND, P:Power input ,O: Digital output
Connector Pin 1 position

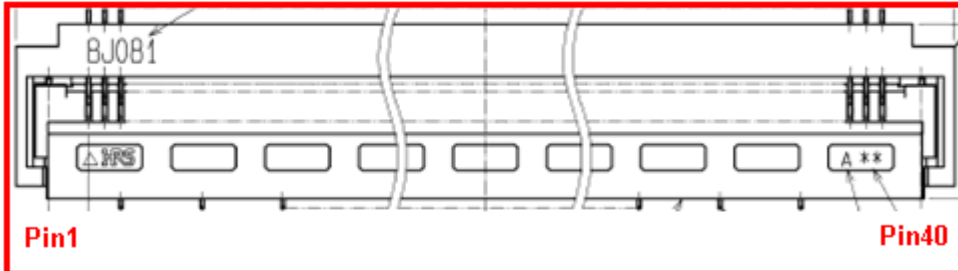

Note: B Pin1 and B Pin42 are connected metal of connector surface, please fixed to ground.

9. Reliability

Content of Reliability Test (Super Wide temperature, -30°C~85°C)

Environmental Test			
Test Item	Content of Test	Test Condition	Note
High Temperature storage	Endurance test applying the high storage temperature for a long time.	95°C 200hrs	2
Low Temperature storage	Endurance test applying the low storage temperature for a long time.	-40°C 200hrs	1,2
High Temperature Operation	Endurance test applying the electric stress (Voltage & Current) and the thermal stress to the element for a long time.	85°C 200hrs	—
Low Temperature Operation	Endurance test applying the electric stress under low temperature for a long time.	-30°C 200hrs	1
High Temperature/ Humidity storage	The module should be allowed to stand at 60 °C,90%RH max	60°C,90%RH 96hrs	1,2
Thermal shock resistance	The sample should be allowed stand the following 10 cycles of operation <div style="text-align: center;"> <p style="margin: 0;">-30°C 25°C 85°C</p> <p style="margin: 0;">30min 5min 30min</p> <p style="margin: 0;">1 cycle</p> </div>	-30°C/85°C 10 cycles	—
Vibration test	Endurance test applying the vibration during transportation and using.	Total fixed amplitude : 1.5mm Vibration Frequency : 10~55Hz One cycle 60 seconds to 3 directions of X,Y,Z for Each 15 minutes	3
Static electricity test	Endurance test applying the electric stress to the terminal.	VS=±600V(contact), ±800v(air), RS=330Ω CS=150pF 10 times	—

Note1: No dew condensation to be observed.

Note2: The function test shall be conducted after 4 hours storage at the normal Temperature and humidity after remove from the test chamber.

Note3: The packing have to including into the vibration testing.

10. Contour Drawing

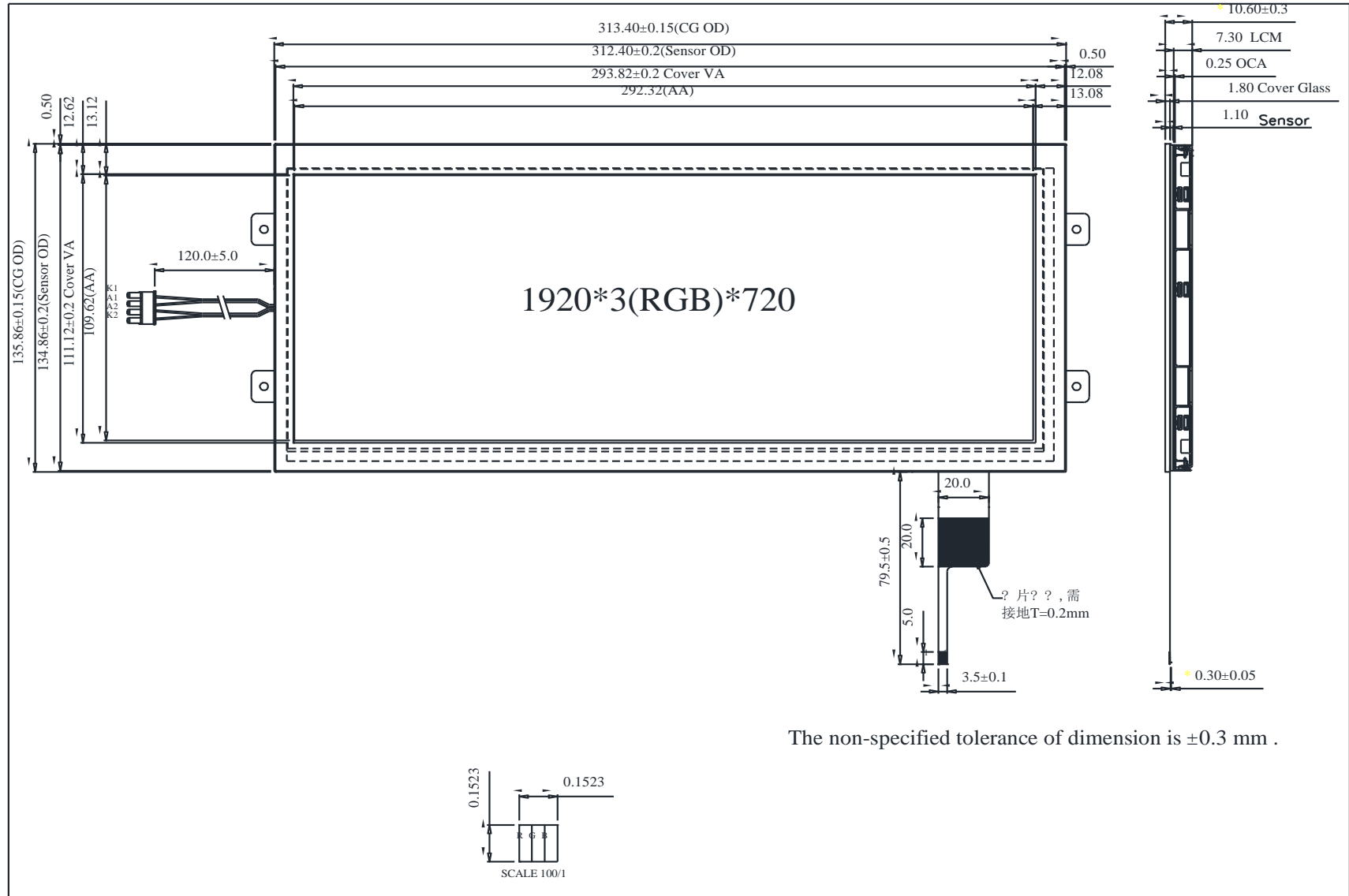

The non-specified tolerance of dimension is ±0.3 mm .

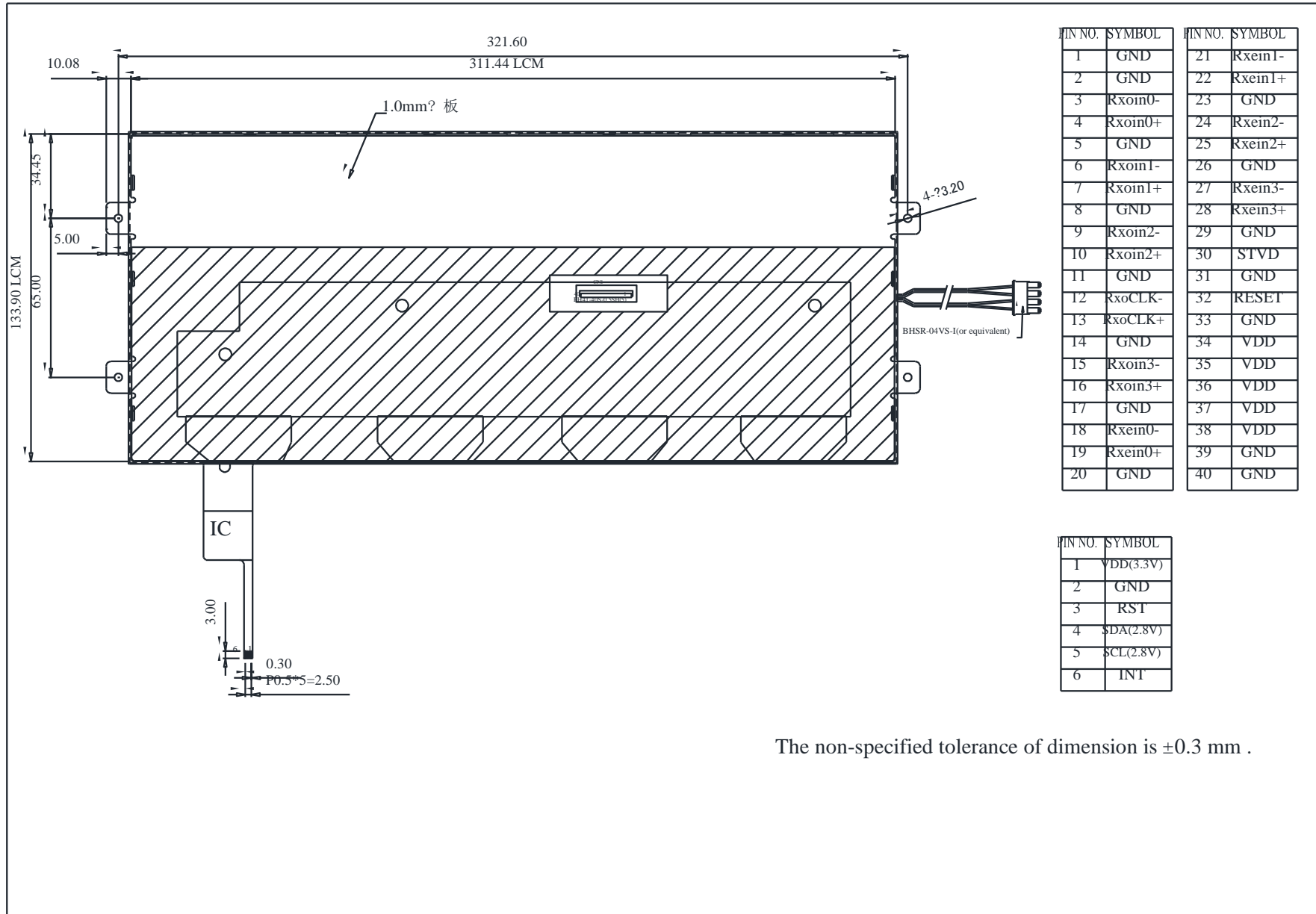

The non-specified tolerance of dimension is ± 0.3 mm .



1、Panel Specification :

- 1. Panel Type : Pass NG , _____
- 2. View Direction : Pass NG , _____
- 3. Numbers of Dots : Pass NG , _____
- 4. View Area : Pass NG , _____
- 5. Active Area : Pass NG , _____
- 6. Operating Temperature : Pass NG , _____
- 7. Storage Temperature : Pass NG , _____
- 8. Others : _____

2、Mechanical Specification :

- 1. PCB Size : Pass NG , _____
- 2. Frame Size : Pass NG , _____
- 3. Material of Frame : Pass NG , _____
- 4. Connector Position : Pass NG , _____
- 5. Fix Hole Position : Pass NG , _____
- 6. Backlight Position : Pass NG , _____
- 7. Thickness of PCB : Pass NG , _____
- 8. Height of Frame to PCB : Pass NG , _____
- 9. Height of Module : Pass NG , _____
- 10. Others : Pass NG , _____

3、Relative Hole Size :

- 1. Pitch of Connector : Pass NG , _____
- 2. Hole size of Connector : Pass NG , _____
- 3. Mounting Hole size : Pass NG , _____
- 4. Mounting Hole Type : Pass NG , _____
- 5. Others : Pass NG , _____

4、Backlight Specification :

- 1. B/L Type : Pass NG , _____
- 2. B/L Color : Pass NG , _____
- 3. B/L Driving Voltage (Reference for LED Type) : Pass NG , _____
- 4. B/L Driving Current : Pass NG , _____
- 5. Brightness of B/L : Pass NG , _____
- 6. B/L Solder Method : Pass NG , _____
- 7. Others : Pass NG , _____

>> **Go to page 2** <<



Winstar Module Number : _____

Page: 2

5、Electronic Characteristics of Module :

- 1. Input Voltage : Pass NG , _____
- 2. Supply Current : Pass NG , _____
- 3. Driving Voltage for LCD : Pass NG , _____
- 4. Contrast for LCD : Pass NG , _____
- 5. B/L Driving Method : Pass NG , _____
- 6. Negative Voltage Output : Pass NG , _____
- 7. Interface Function : Pass NG , _____
- 8. LCD Uniformity : Pass NG , _____
- 9. ESD test : Pass NG , _____
- 10. Others : Pass NG , _____

6、Summary :

Sales signature : _____

Customer Signature : _____

Date : / / _____