

THE MOST FLEXIBLE NETWORK CONNECTIVITY SOLUTION

Designed for quick integration with minimal engineering effort, the chip-sized xPico provides simplicity and flexibility making it the easiest and fastest networking-enabling module on the market.

xPico is an extremely compact networking solution that enables Ethernet connectivity on virtually any device with a serial interface. The included industry-proven Lantronix device server application and full IP stack allow seamless remote access to device data simplifying design integration while providing robust connectivity.

As the smallest embedded device server in the world, xPico can be utilized in designs typically intended for chip solutions. A key difference with the xPico is that there is virtually no need to write a single line of code, translating to a much lower development cost and faster time-to-market.



xPico Highlights:

- > Chip-sized Footprint: 24mm x 16.5mm
- > Complete Device Server Application with Full IP Stack and Web Server
- > Serial Data Rate of up to 921 Kbps
- > 256-bit AES Encryption
- > Extended Temperature: -40° to +85° C
- > 5-Year Limited Warranty

xPico in Alarm Control Panel Application

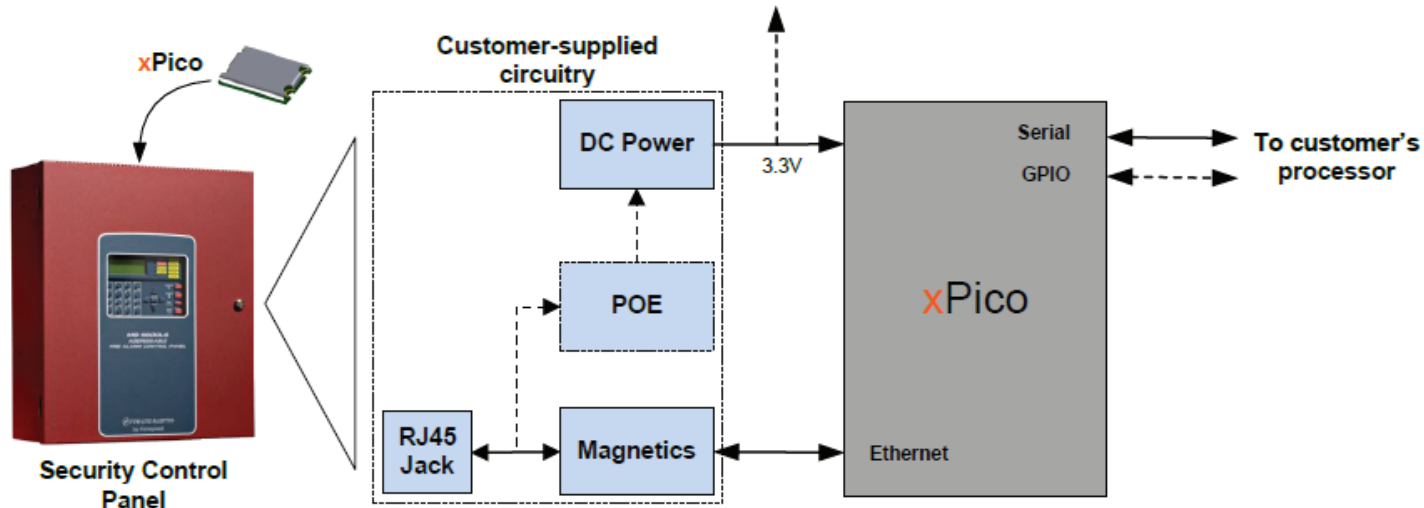

Features and Specifications

> Serial Interface

- Interface: CMOS (Asynchronous) 3.3V-level signals (5V tolerant)
- Data Rates: 300bps to 921,600bps (software selectable)
- Data Bits: 7 or 8
- Stop Bits: 1 or 2
- Parity: Odd, Even, None
- Control Signals: DTR/DCD, RTS/CTS
- Flow Control: XON/XOFF (software), CTS/RTS (hardware), None
- Programmable I/O: 8 PIO pins (software selectable)

> Network Interface

- Interface: Ethernet 10Base-T or 100Base-TX (Auto-sensing)
- Protocols: TCP/IP, UDP/IP, ARP, Telnet, ICMP, SNMP, DHCP, BOOTP, TFTP, AutoIP, and HTTP

> Management

- SNMP, Telnet, Serial, Internal Web Server, and Microsoft Windows-based utility for web configuration

> Security

- 256-bit AES Encryption

> Internal Web Server

- Storage Capacity: 384KB for Web Pages

> Architecture

- CPU: Based on the DSTni-EX Enhanced 16-bit x86 Architecture
- Memory: 256KB SRAM, 512KB Flash
- Firmware: Upgradeable via TFTP and Serial Port

> Power

- Input Voltage: 3.3VDC

> Physical Interface

- 40-pin Board-to-Board SMT Connector

> Environmental

- Operating Temperature: -40° to +85° C
- Storage Temperature: -40° to +85° C

> Included Software

- MS Windows-based DeviceInstaller
- MS Windows-based Com Port Redirector

> Packaging

- Dimensions: 24mm (L) x 16.5mm (W) x 5.64mm (H)
- Weight: 2.5g

> Warranty

- 5-Year Limited

Ordering Information

United States

Call: 800.422.7055

Email: sales@lantronix.com

Buy Online: <http://www.lantronix.com>

Europe

Call: +31 (0) 76.52.3.6.74 4

Email: EMEA@lantronix.com

Asia/Pacific

Call: +852 3428.2338

Email: asiapacific_sales@lantronix.com

Japan

Call: +81.3.6277.8802

Email: japan_sales@lantronix.com

> Part Number

XPC100100B-01

XPC100100S-01

XPC100100K-01

> Description

xPico Device Server Module, Extended Temperature, AES Encryption, Bulk, RoHS

xPico Device Server Module, Extended Temperature, AES Encryption, Sample, RoHS

xPico Device Server Module Development Kit, Module included, RoHS



The built-in Web Manager makes configuring xPico quick and easy!



xPico – Smaller than a standard SD card.

Actual size: 24mm X 16.5mm (Bottom view of xPico)