

2I268C

**Cedarview-M N2600/N2800 + NM10 / DDR3 800/1066
MHz / DVI / LAN / Audio / USB / PCIe mini card**

All-In-One

**Intel Cedarview-M N2600/N2800, 1.6/1.86GHz
VGA, DVI, LVDS, PCIe mini card
Multi-COM Board, Audio, LAN, SATA, USB**

NO. 2I268C

Release date: August. 22 . 2013

Contents

2I268C	
Warning!	1
Hardware Notice Guide	2
CHAPTER 1 GENERAL INFORMATION	4
1-1 MAJOR FEATURE	5
1-2 SPECIFICATION	6
1-3 INSTALLING THE MINI PCI-E CARD	7
1-4 PACKING LIST	9
CHAPTER 2 HARDWARE INSTALLATION	10
2-1 UNPACKING PRECAUTION	10
2-2 UNPACKING CHECKUP	11
2-3 DIMENSION-2I268C-DH26	12
2-4 LAYOUT-2I268C-DH26	13
2-5 DIAGRAM-2I268C-DH26	14
2-5-1 BOTTOM SIDE DIAGRAM-2I268C-DH26	15
2-6 LIST OF JUMPERS	16
2-7 JUMPER SETTING DESCRIPTION	16
2-8 CMOS DATA SET	16
2-9 JVL1: LCD PANEL POWER SELECT	17
CHAPTER 3 CONNECTION	18
3-1 LIST OF CONNECTORS	18
3-2 AUDIO PORT	20
3-3 GRAPHIC / VIDEO PORT CONNECTOR	21
3-4 COM PORTS	23
3-5 FRONT PANEL CONNECTOR	24
3-6 DIGITAL INPUT / OUTPUT / WATCH DOG TIME	24
3-6-1 IO DEVICE: F75111 UNDER DOS	25
3-6-2 IO DEVICE: F75111 UNDER WINDOWS	26
3-6-3 IO DEVICE: F75111 VB6 UNDER WINDOWS	29
3-6-4 IO DEVICE: F75111 UNDER LINUX	31
3-7 TOUCH SCREEN DEVICE	35
3-8 I ² C BUS INTERFACE	35
3-9 DC -IN POWER CONNECTOR	36
3-10 CMOS BATTERY CONNECTOR	36
3-11 LAN PORT	37
3-12 USB PORTS	38
3-13 DC+5/+12V VOLTAGE OUTPUT CONNECTOR	39
3-14 SATA INTERFACE	39
3-15 MINI AND SIM CARD	40

CHAPTER 4 INTRODUCTION OF BIOS	41
4-1 ENTER SETUP	41
4-2 GETTING HELP	42
4-3 THE MAIN MENU	42
4-4 STANDARD CMOS FEATURES	44
4-5 ADVANCED BIOS FEATURES	45
4-5-1 HARD DISK BOOT PRIORITY	47
4-5-2 USB BOOT PRIORITY	47
4-6 ADVANCED CHIPSET FEATURES	48
4-6-1 PCI EXPRESS ROOT PORT FUNC	49
4-7 INTEGRATED PERIPHERALS	50
4-7-1 OnCHIP IDE DEVICE	50
4-7-2 SUPER IO DEVICE	51
4-7-3 USB DEVICE FUNCTION	52
4-8 POWER MANAGEMENT SETUP	53
4-8-1 PCI EXPRESS PM FUNCTION	55
4-9 PNP/PCI CONFIGURATION SETUP	55
4-9-1 IRQ RESOURCES	56
4-10 PC HEALTH STATUS	57
4-11 LOAD OPTIMIZED DEFAULTS	57
4-12 SET SUPERVISOR / USER PASSWORD	68
CHAPTER 5 DRIVER INSTALLATION	59
5-1 INF INSTALL INTEL CEDARVIEW CHIPSET DRIVER	61
5-2 VGA INSTALL INTEL CEDARVIEW VGA DRIVER	63
5-3 SOUND INSTALL VIA HD AUDIO CODEC DRIVER	65
5-4 HOW TO UPDATE BIOS	67
APPENDIX A: POWER CONSUMPTION TEST.....	68
APPENDIX B: RESOLUTION LIST	69

Copyright

This manual is copyrighted and all rights are reserved. It does not allow any non authorization in copied, photocopied, translated or reproduced to any electronic or machine readable form in whole or in part without prior written consent from the manufacturer.

In general, the manufacturer will not be liable for any direct, indirect, special, incidental or consequential damages arising from the use of inability to use the product or documentation, even if advised of the possibility of such damages.

The manufacturer keeps the rights in the subject to change the contents of this manual without prior notices in order to improve the function design, performance, quality, and reliability. The author assumes no responsibility for any errors or omissions, which may appear in this manual, nor does it make a commitment to update the information contained herein.

Trademarks

Intel is a registered trademark of Intel Corporation.

Award is a registered trademark of Award Software, Inc.

All other trademarks, products and or product's name mentioned here are for identification purposes only, and may be trademarks and/or registered trademarks of their respective companies or owners.

©Copyright 2013

All Rights Reserved.

User Manual edition 0.1, August .22. 2013

Warning !

1. Battery

Battery on board is consumables. We doesn't guarantee the life time of it.

2. Fanless solution with HDD

Please be aware of specification & limitation for HDD when fanless solution is implemented.

3. We will not give further notification if there is any change about the product information and the manual.

4. SATA does not support Hot SWAP.

5. There would be $\pm 20\%$ difference of WDT at room temperature.

6. Please make sure the voltage specification meet the requirement of the equipment before plugging into the power.

7. SSD has 2 types, commercial grade and industrial grade, which provide different read/write speed, operation temperature and life cycle. Please contact sales for further information before ordering.

8. Caution ! Please notice that the heat dissipation problem could cause the MB system unstable. Please handle the heat dissipation properly when buying single MB.

9. Please avoid to approach the heat sink area and prevent being scalded when using the Fanless products.

10. If the users repair, modify or destroy any component of product unauthorized, We would not take responsibility or provide warranty.

11. DO NOT apply any other material onto the thermal pad in case reducing cooling performance.

12. It is important to install a System Fan toward the CPU to prevent the possibility of overheating / system hang up issues from Cedar view-D series of motherboard or else customer is required to have well cooling system to dissipate heat from CPU.

* Hardware Notice Guide

1. Before installing the power supply with this motherboard, please attach the 12V/DC (2 pin connector)of the adapter to motherboard first.
After that, plug the adapter power to AC outlet.
Always normally shut down the computer before you move the system unit or remove the power supply from the motherboard.
Please unplug the 12V/DC (2 pin connector) of the adapter from motherboard first.
Then unplug the adapter from the AC outlet.
Please refer to procedure from the photo 1
2. There will be high possibility to burn out the CPU if you change/ modify any parts of the CPU cooler.
3. Please wear wrist strap and attach it to a metal part of the system unit before handling a component.
You can also touch an object that is of ground connection or with metal surface if you don't have wrist strap.
4. Please be careful when you handle this product. Pay attention to & don't touch the sharp-pointed components at the bottom PCB .
5. Please pay attention to this: Remove or change any components form the motherboard will VOID the warranty of the motherboard you purchased .
6. Before you install/remove any components or make any jumper setting on the motherboard, please make sure to disconnect the power first.
(Please follow the instructions as of this guide)
7. Please only use single side Mini PCIe card, do not use the double side Mini PCIe card which is not suitable.
8. Please follow this instruction carefully when using the "POWERON after PWR-Fair" function.
When the DC power adaptor runs out of power, unplug it from the DC current;
when power returns plug it back in only after 5 seconds. If there is a power outage, unplug it from the AC current, when power returns plug it back in only after 30 seconds.
Otherwise it will cause system locking or serious damage.

Remark 1:

Always insert/unplug the 12V/DC (2 pin connector) horizontally & directly from the motherboard.

DO NOT twist the 12V/DC (2 pin connector) gently, it is designed to fit snugly .

Moreover, erratic pull / push testing with the DC Jack might cause the unpredictable damage to the component & system unit.

Photo 1

Insert

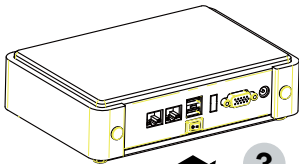
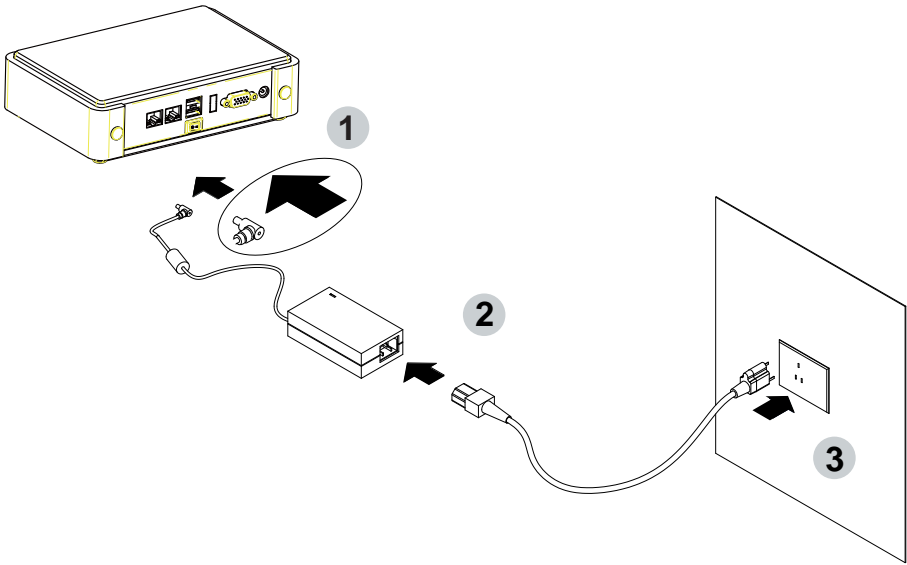

Unplug

Chapter-1

General Information

The 2I268C is a 2.5 inches form factor All-In-One Board. The board design combines all necessary input and output effects interfaces, which makes itself an ideal all-in-one control board for POS, Digital Signage and Automation application. Due to its compact size, 2I268C is also the perfect platform for a whole range of small form factor and low-power devices, such as mobile PC or small panel PC

The 2I268C All-In-One motherboard is with Intel Cedar view-M N2600 1.6GHz / N2800 1.86GHz CPU (Dual core processor), Intel Cedarview-M + NM10 chipset and Intel Cedar view-M Integrated Graphics chipset. This integrated Cedar View platform offers superb performance and PC specification in the industry. Despite the limited space of 2I268C, it supports 2 COM ports of RS232(or RS485) and 5 ports of Hi-Speed USB 2.0 to enhance the host controller interface which will ensure the high performance level and flexible expansion.

2I268C is supported with one 10/100/1G Ethernet for seamless broadband connectivity. With Wake-On LAN function and the PXE function in BIOS, these are perfect control boards for networking devices. The built-in Lan is RTL8111F LAN chipset for PCIe x 1 interface, integrated 10/100/1000 transceiver.

The 2I268C motherboard is built in on board DDR3 SDRAM 2GB, N2600 / N2800 Memory DDR3 data transfer rate of 800MT/s / 1066MT/s and optional with On board SATA SSD 2/4/8/16/32/64---GBytes. The expendable interfaces include one full size PCIe Mini card for PCIe by one and USB interface, one half size PCIe Mini card for mSATA and USB interface.

The All-In-One motherboard 2I268C is fully compatible with industry standards, plus technical enhancements and thousands of software applications developed for IBM PC/AT compatible computers. These control logic provides high-speed performance for the most advanced multi user and multitasking applications available today.

1-1 Major Feature

1. Intel Cedarview-M N2600 1.6GHz CPU / N2800 1.86GHz CPU
2. Intel Cedarview-M and NM10 chipset on board
3. Intel Cedarview-M Integrated Graphics chipset, N2600 400 MHz or N2800 640 MHz render clock frequency. Support Directx* 10.1 compliant Pixel Shader* v2.0 and OGL 3.0
4. On board DDR3 SDRAM 2GB, N2600 / N2800 Memory DDR3 data transfer rate of 800MT/s / 1066MT/s.
5. On board SSD 2/4/8/16/32/64 GBytes (Option)
6. Support 1 x 10 / 100 / 1000 Mbps Realtek LAN
7. Support extended 2 x Mini PCIe card (full size & half size)
8. One SATA port with independent DMA operation supported
9. 1 x DVI support resolution up to 1920 x 1200
10. Hardware digital Input & Output, 4 x DI / 4 x DO
Hardware Watch Dog Timer, 0~255 sec programmable
11. On board DC +12V
12. PCB Dimension: 102 x 73 mm (2.5 inch)
13. One 3G SIM card socket (Option)
14. USB /COM interface Touch screen controller, support 4- , 5- , 8- wire Analog Resistive touch screen. Resolution is up to 2048 x 2048.

1-2 Specification

1. **CPU:** Intel Cedarview-M N2600 / N2800
2. **Chipset:** Intel Cedarview-M and NM10
3. **Memory:** DDR3 SDRAM 2GB, N2600 / N2800 Memory DDR3 data transfer rate of 800MT/s / 1066MT/s.
4. **SATA:** One SATA port with independent DMA operation supported
5. **NAND** flash memory (Option):
On board SATA SSD 2/4/8/16/32/64---GBytes (Option)
6. **LAN:** 1 x Realtek RTL8111F 10 / 100 / 1000 Mbps
7. **Serial Port:** External x 1 optional with Line out & 2 x USB;
internal x 1 share with Audio AMP
8. **USB:** 5 x USB 2.0 (2 external + 3 internal)
9. **Sound:** Intel High Definition Audio Specification Rev.1.0 Compliant
10. **Audio Amplifier:** Two channel Class D Audio Amplifier. 2.57W/Ch (Typ.) into a 4 Ω Load;
1.46 W/Ch (Typ.) into a 8 Ω Load (Option)
11. **WDT/DIO:** Hardware digital Input & Output, 4 x DI / 4 x DO /
Hardware Watch Dog Timer, 0~255 sec programmable
12. **Expansion interface:** One full size PCIe Mini card for PCIe by one and USB interface;
One half size PCIe Mini card for mSATA and USB interface
13. **BIOS:** Award BIOS Version
14. **Dimension:** 102 x 73 mm (2.5 inch)
15. **Power:** On board DC +12V
16. **Power Consumption:** Please refer to Page. 68
17. **3G Wireless:** 3G SIM card reader (Option)
18. **LVDS:** 18 bits LVDS
19. Touch function: USB /COM interface Touch screen controller, support 4- , 5- , 8-
wire Analog Resistive touch screen. Resolution is up to 2048 x 2048 (option)

1-3 Installing the MINI PCI-E Card

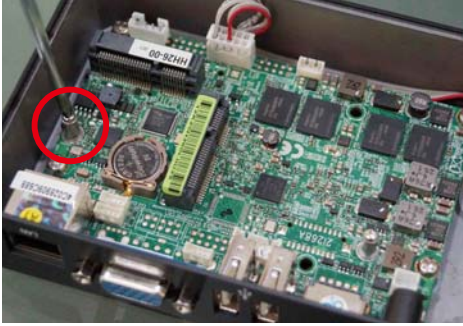

1. Unfasten the round-headed M2*6 screw for half size MINI PCI-E.

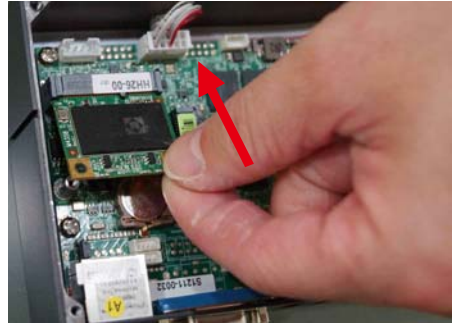

2. Install a mSATA card at the angle of 45°. (The half size MINI PCI-E slot supports mSATA)

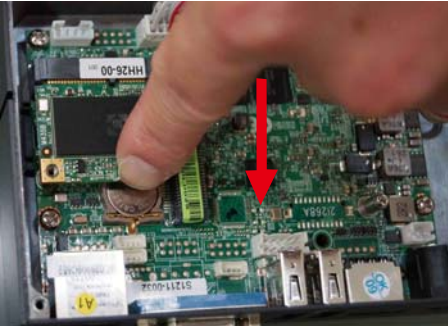

3. Push it down.



4. Fasten a round-headed M2*6 screw.



5. Unfasten the round-headed M2*6 screw for the full size MINI PCI-E.



6. Install the full size MINI PCI-E card at the angle of 45°. (Such as 3G card module, Wireless card module or GPS card module)



7. Push it down.



8. Fasten round-headed M2*6 screw.

1-4 Packing List

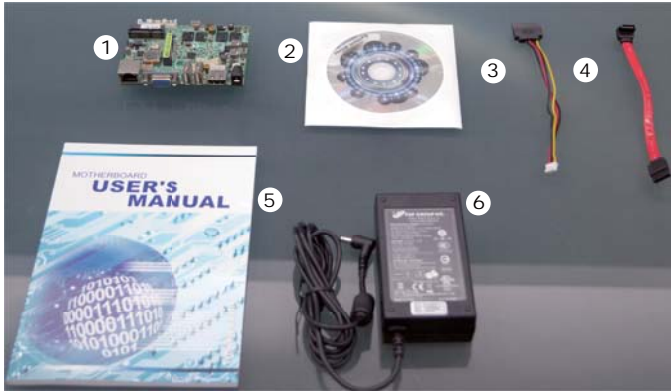

	Material Code	Description	Detail Specification	Quantit
1	7G1901-1251001-0	MB-2I268C-DH26-00-001	LF,2I268C-DH26-00,Rev.:001	1
2	6G8006-2344-0100	DVD	LF,Intel Cedarview-MD,Sandy Bridge	1
3	6G6003-1006-0100	SATA Power Cable	LF,L=15cm,SATA to 2.0/1*4	1
4	6G6001-2208-0100	SATA DATA Cable,(Red)	LF,L=15cm	1
5	6G8001-2175-0400	Manual	LF,MB,2I268C	1
6	6G5212-0301-0300	30W Power Adapter,12V/2.5A	LF,L Type,EA10301-M06,EDAC	1

*The packing list above is for the users who purchase single motherboard. The users who purchase the board with chassis may refer to the packing list in the Assembly Guide.

Please contact with your dealer if any of these items is missing or damaged on delivery. And please keep all parts of the delivery package with packing materials in case if you need to deliver or store the product in the future.

Chapter-2

Hardware Installation

This chapter provides the information how to install the hardware of 2I268C . Please follow section 1-4, 2-1 and 2-2 to check the delivery package and unpack carefully. Please follow the jumper setting procedure.

2-1 Unpacking Precaution

The 2I268C board has been well packed with an anti-static bag to protect its sensitive components and circuitry from damage due to static electric discharge.

NOTE!

1. Do not touch the board or any other sensitive components without all necessary anti-static protection.
2. Please pay attention to the voltage limitation of DC-IN12 V \pm 5 %.
Overuse of DC-IN voltage limitation or change to another power adapter (not provided with this system) will VOID warranty.

You should follow these steps to protect the board from the static electric discharge whenever you handle the board:

1. Ground yourself by a grounded wrist strap at all times when you handle the 2I268C.
Well secure the ALLIGATOR clip of the strap to the end of the shielded wire lead from a grounded object. Please put on and connect the strap before handling the 2I268C for harmlessly discharge any static electricity through the strap.
2. Please use anti-static pad to put any components, parts, or tools on the pad whenever you work on them outside the computer. You may also use the anti-static bag instead of the pad. Please ask your local supplier for necessary parts on anti-static requirement.
3. Do not plug any connector or set any jumper when the power is on.

2-2 Unpacking checkup

First of all, please follow all necessary steps of section 2-1 to protect 2I268C from electricity discharge. With reference to section 1-4 please check the delivery package again with following steps:

1. Unpack the 2I268C board and keep all packing material, manual and driver disc etc, do not dispose !
2. Is there any components lose or drops from the board? DO NOT CONTINUE TO INSTALL THIS BOARD! CONTACT THE DEALER YOU PURCHASED THIS BOARD FROM, IMMEDIATELY.
3. Is there any visible damage on the board? DO NOT CONTINUE TO INSTALL THIS BOARD!CONTACT THE DEALER YOU PURCHASED THIS BOARD FROM, IMMEDIATELY.
4. Check your optional parts (i.e. DDR, CF etc.), all necessary jumpers setting to jumper pin-set, and CMOS setup correctly.
Please also refer to all information of jumper settings in this manual.
5. Check your external devices (i.e. Add-On-Card, Driver Type etc.) for complete add-in or connection and CMOS setup correctly.
Please also refer to all information of connector connection in this manual.
6. Please keep all necessary manual and driver disc in a good condition for future re-installation if you change your Operating System.

2-3 Dimension - 2I268C - DH26

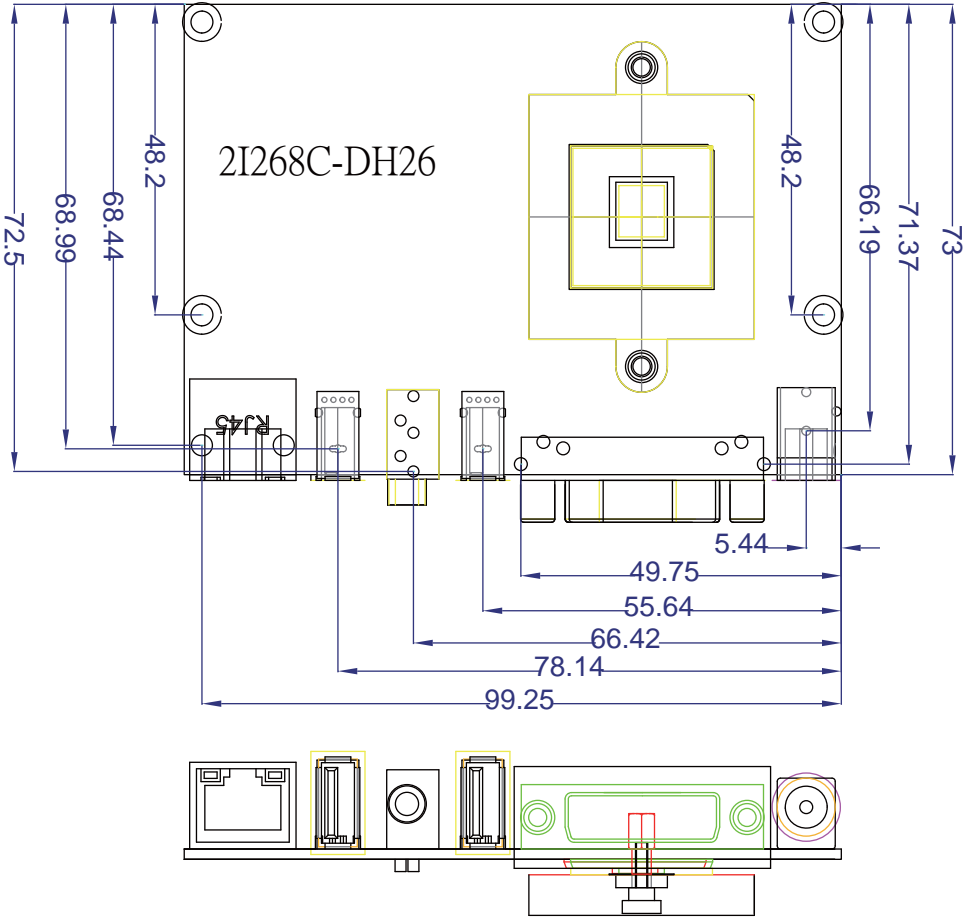

2-4 Layout- 2I268C-DH26

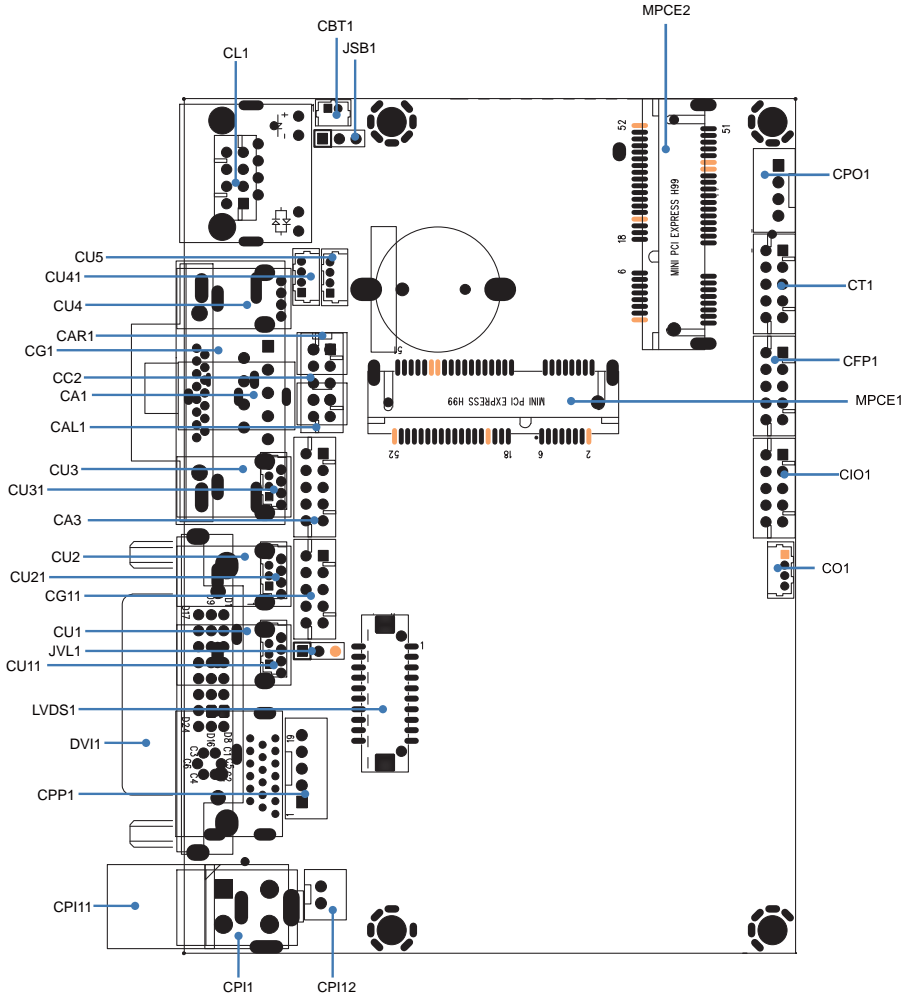

2-5 Diagram- 2I268C-DH26

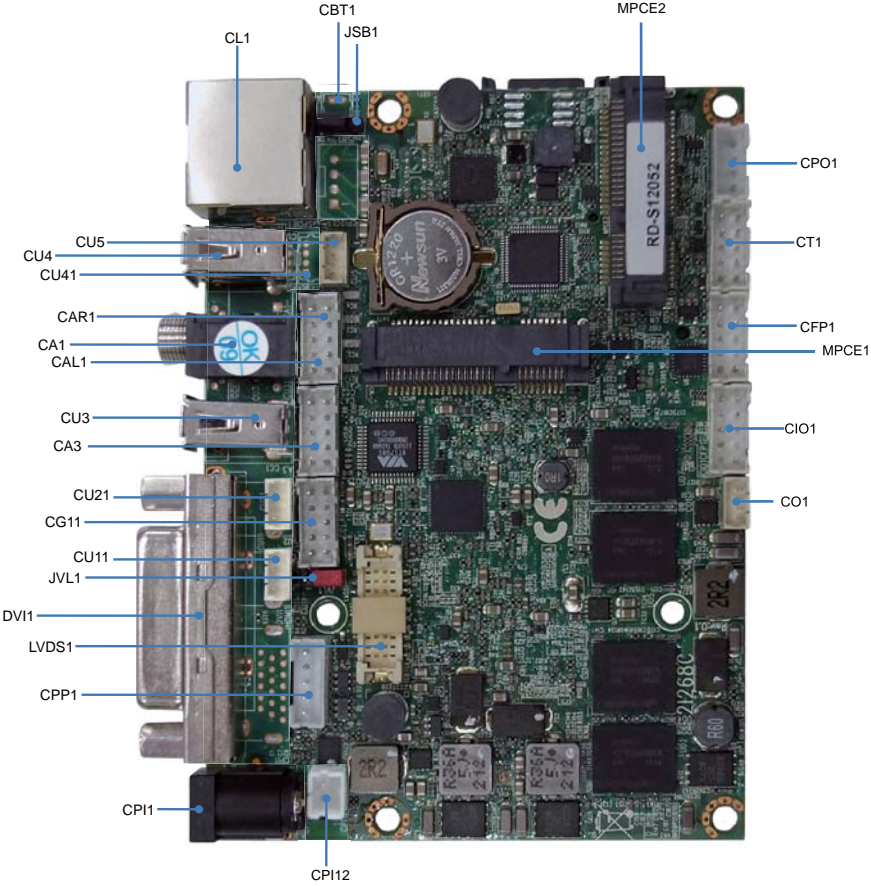

Back Panel

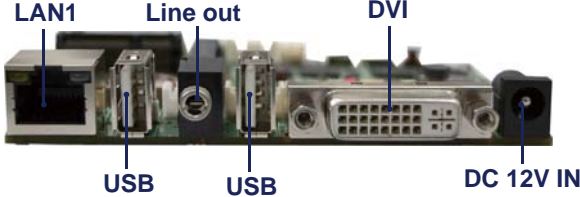

2-5-2 Bottom Side Diagram-2I268C-DH26

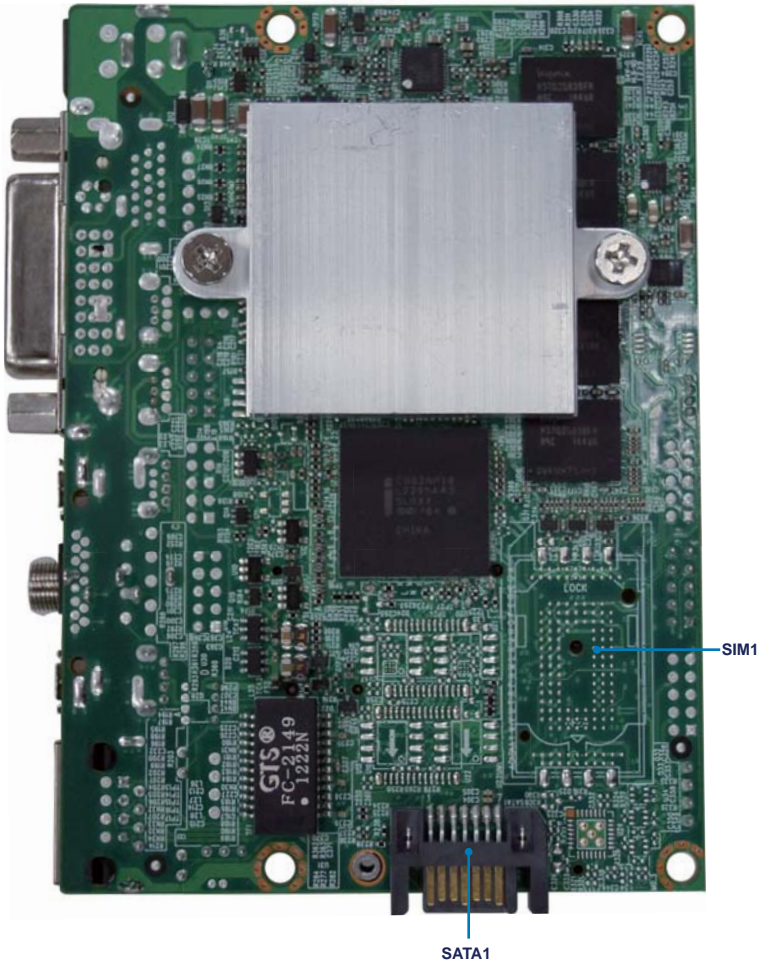

2-6 List of Jumpers

JSB1: CMOS DATA SET

JVL1: LCD panel power select

2-7 Jumper Setting Description

A jumper is ON as a closed circuit with a plastic cap covering two pins. A jumper is OFF as an open circuit without the plastic cap. Some jumpers have three pins, labeled 1, 2, and 3. You could connect either pin 1 and 2 or 2 and 3.

The below figure 2.2 shows the examples of different jumper settings in this manual.

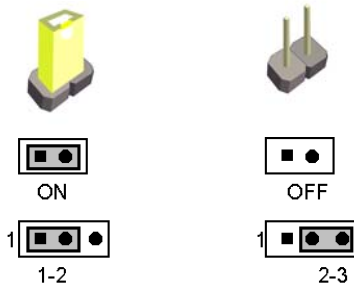

Figure 2.2

All jumpers already have its default setting with the plastic cap inserted as ON, or without the plastic cap as OFF. The default setting may be referred in this manual with a " * " symbol .

2-8 CMOS Data Set

A battery must be used to retain the motherboard configuration in CMOS RAM. Close pin 1 and pin 2 of JSB1 to store the CMOS data.

To clear the CMOS, follow the procedures below:

1. Turn off the system and unplug the AC power
2. Remove DC 12V power cable from DC 12V power connector
3. Locate JSB1 and close pin 2-3 for a few seconds
4. Return to its normal setting by shorting pin 1-2
5. Connect DC 12V power cable back to DC 12V power connector

JSB1: CMOS DATA SET

JSB1	Description
*1-2	*Normal Set
2-3	CMOS Data Clear

Note: Do not clear CMOS unless
1. Troubleshooting
2. Forget password
3. You fail over-clocking system

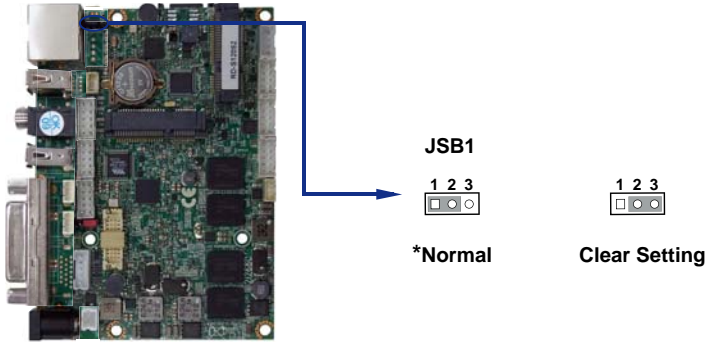

2-9 JVL1: LCD panel power select

JVL1	Description
1-2	+5V
*2-3	+3.3V

Note: Please be cautious about voltage setting.

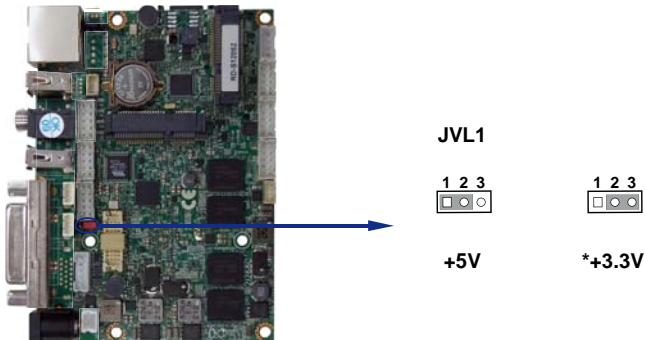

Chapter-3

Connection

This chapter provides all necessary information of the peripheral's connections, switches and indicators. Always power off the board before you install the peripherals.

3-1 List of Connectors

- CPI1 : DC 12V-IN Power Jack
- CPI12 :DC-in 1x2 pin (2.0mm) Wafer connector
- CPI11 : DC-In 2x2 pin (4.20mm) Wafer connector (Option)
- CBT1 : 3V Battery 1x2pin(1.25mm)Wafer (Option)
- BAT1 : 3V Battery hold 2pin
- CPO1 : +12V/+5V power output 4 pin (2.0mm) Wafer
- CFP1 : FP port 2x5 pin (2.0mm) Wafer
- CG1 : VGA DB15 connector (Option)
- CG11 : VGA port 2x5 pin (2.0mm) Wafer
- DVI1 : DVI-D port connector
- HDMI1 : HDMI 1.3a port Type A connector (Option)
- LVDS1 : LVDS 18 Bits 2x10 pin (1.25mm) connector
- CPP1 : Panel inverter power connector 1x5 pin (2.0mm) Wafer
- CT1 : Touch screen device 2x5 pin (2.0mm) Wafer
- CA1 : Line-out phone jack
- CA3 : Line-out/Line-in/Mic-in 2x5 pin (2.0mm) Wafer
- CAR1,CAL1 : Two Channel Speak out ports 2pin (2.0mm) Wafer (Option)
- CC1 : COM1 DB9pin connector (Option)
- CC2 : COM2 2x5 pin (2.0mm) Wafer
- CIO1 : One DIO 2x5 pin (2.0mm) Wafer
- CO1 : I²C 4pin (1.25mm) Wafer
- CL1 : LAN port RJ45
- CL1 : LAN port 2x4pin (2.0mm) Wafer (Option)
- CU1 : USB1 port Type A connector (Option)
- CU11 : USB1 port 4pin(1.25mm) Wafer

List of Connectors

CU2 : USB2 port Type A connector (Option)

CU21 : USB2 port 4pin(1.25mm) Wafer

CU3 : USB3 port Type A connector

CU31 : USB3 port 4pin(1.25mm) Wafer (Option)

CU4 : USB4 port Type A connector

CU41 : USB 4 port 4pin(1.25mm) Wafer (Option)

CU5 : USB 5 port 4pin(1.25mm) Wafer

SATA1: One SATA connector 7pin

MPCE1/2 : Two Mini card socket 52pin

SIM1 : SIM card socket (Option)

3-2 Audio Port

The 2I268C has an on-board AC'97 3D sound interface.

There are the connectors of LINE OUT, MIC-IN and Line-IN connectors.

The MIC-IN Jack and Line-IN header are for audio sound input. The LINE-OUT connector is a 4-pin Jack for audio sound output.

CA1: Line-out phone jack

CA3: Line-out / Line-in / Mic-in 2x5 pin (2.0mm) Wafer

CAR1,CAL1: Two Channel Speak out ports 2pin (2.0mm) Wafer

● CA1: Line out connector (3.5mm Phone jack)

PIN NO.	1	2	3	4	5
Description	GND	Line-out-R	NC	Line-out-L	NC

● CA3: Audio port (2x5pin 2.0mm Wafer)

PIN NO.	Description	PIN NO.	Description
1	Line-out-R	2	MIC-IN
3	Line-in-R	4	GND
5	GND	6	GND
7	Line-in-L	8	NC
9	Line-out-L	10	MIC-IN

Audio Amplifier class D Two channel 6W/8Ω (Option)

2.57W/Ch (Typ.) into a 4ΩLoad

1.46 W/Ch (Typ.) into a 8ΩLoad

● CAR1: Audio Amplifier Line Out Right (2pin 2.0mm wafer)

PIN NO.	Description
1	LINE-OUT_R+
2	LINE-OUT_R-

● CAL1: Audio Amplifier Line Out Left(2pin 2.0mm wafer)

PIN NO.	Description
1	LINE-OUT_L+
2	LINE-OUT_L-

Note : 1. CAR1 and CAL1 connector share to CC2 Wafer.

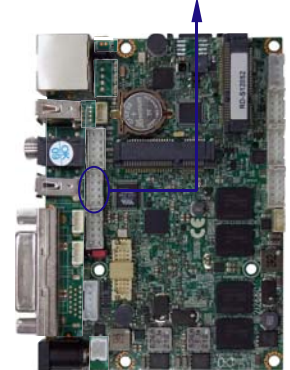
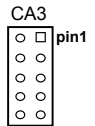

3-3 Graphic / Video port Connector

● CG1: VGA DB15 connector

PIN NO.	Description	PIN NO.	Description	PIN NO.	Description
1	RED	2	GND	11	NC
3	GREEN	4	GND	12	DDC DATA
5	BULE	6	GND	13	H-SYNC
7	NC	8	Don't use	14	V-SYNC
9	GND	10	GND	15	DDC CLOCK

● CG11: VGA 2x5pin 2.0mm wafer connector

PIN NO.	Description	PIN NO.	Description
1	BULE	2	GND
3	GND	4	DDC CLOCK
5	GREEN	6	V-SYNC
7	GND	8	H-SYNC
9	RED	10	DDC DATA

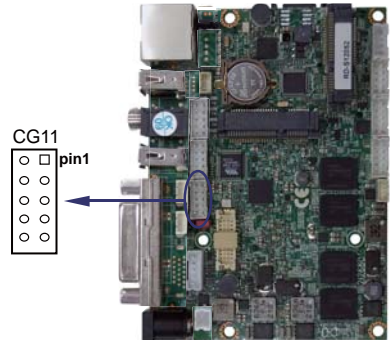

● HDMI1 : HDMI Connector

PIN NO.	DESCRIPTION	PIN NO.	DESCRIPTION
1	TMDS DATA2+	2	GND
3	TMDS DATA2-	4	TMDS DATA1+
5	GND	6	TMDS DATA1-
7	TMDS DATA0+	8	GND
9	TMDS DATA0-	10	TMDS CLK+
11	GND	12	TMDS CLK-
13	NC (CEC)	14	NC
15	DDC CLOCK	16	DDC DATA
17	GND	18	+5V
19	H.P. Detect		



Note : Share DVI1 position

● DVI1 : DVI-D connector (DB Connector)

PIN NO.	Description	PIN NO.	Description	PIN NO.	Description
1	Data 2-	9	Data 1-	17	Data 0-
2	Data 2+	10	Data 1+	18	Data 0+
3	GND	11	GND	19	GND
4	NC	12	NC	20	NC
5	NC	13	NC	21	NC
6	DDC-CLK	14	+5V	22	GND
7	DDC-DATA	15	GND	23	CLK+
8	NC	16	H.P.Detect	24	CLK-

Note : DVI1 only use DVI-D

● **LVDS1 : 18bits LVDS interface from CDV chipset(2x10 pin 1.25mm wafer)**

PIN NO.	Description	PIN NO.	Description
1	Channel-DATA0+	2	+5V (OR +12V)
3	Channel-DATA0-	4	GND
5	Channel-DATA1+	6	GND
7	Channel-DATA1-	8	GND
9	Channel-DATA2+	10	GND
11	Channel-DATA2-	12	+LCD(5V or 3.3V)
13	Channel-DATA3+	14	+LCD(5V or 3.3V)
15	Channel-DATA3-	16	+LCD(5V or 3.3V)
17	Channel-CLK+	18	ENBKL (+3.3V)
19	Channel-CLK-	20	BRIGHT/ PWM dimming

- Note :
1. Attention ! Check Device Power in spec
 2. CDV-M N2600 /N2800 support LVDS 18Bits
 3. Pin2 +5V power define by BOM for small size panel backlight power use
 4. Pin12/14/16 provide LCD panel power set by JVL1: LVDS panel +5V/+3.3V Voltage select
 5. Pin 18 Backlight enable output, Hi enable (+3.3V) , Low disable (0V)
 6. Pin 19 backlight dimming control. provided 200Hz / 275Hz / 380Hz / 20KHz /25KHz and adjust PWM duty cycle by software program .
 7. PWM duty cycle 100 % is Hi level +3.3V by power on default.

● **CPP1: Panel backlight power (5pin 2.0mm wafer)**

PIN NO.	Description
1	+12V
2	GND
3	BRIGHT/ PWM dimming
4	ENBKL (+3.3V)
5	ENBKL (+ 5V)

- Note :
1. Attention ! Check Device Power in spec
 2. Pin 3 backlight dimming control .provided 200Hz / 275Hz / 380Hz / 20KHz /25KHz and adjust PWM duty cycle by software program .
 3. PWM duty cycle 100 % is Hi level +3.3V by power on default.
 4. Pin 4 Backlight enable output, Hi enable (+3.3V) , Low disable (0V)
 5. Pin 5 Backlight enable output, Hi enable (+5V) , Low disable (0V)

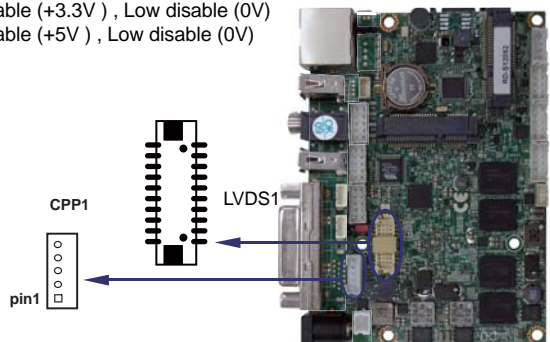

3-4 COM Ports

CC1 : COM1 DB9 connector

CC2 : COM2 2x5 pin (2.0mm) Wafer

● CC1 :RS232 Mode COM1 conector (D-SUB 9pin)

PIN NO.	Description	PIN NO.	Description
1	DCD	6	DSR
2	RXD	7	RTS
3	TXD	8	CTS
4	DTR	9	RI
5	GND		

● CC1 :RS485/422 Mode COM1 conector (D-SUB 9pin)

PIN NO.	Description	PIN NO.	Description
1	TXD-	6	NC
2	TXD+	7	NC
3	RXD-	8	NC
4	RXD+	9	NC
5	GND		

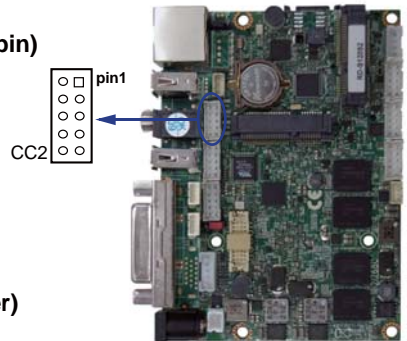

● CC2: COM2 for RS232 ports (2x5pin 2.0mm Wafer)

PIN NO.	Description	PIN NO.	Description
1	DCD	2	RXD
3	TXD	4	DTR
5	GND	6	DSR
7	RTS	8	CTS
9	RI	10	+5V

● CC2: COM2 for RS485/422 ports (2x5pin 2.0mm Wafer)

PIN NO.	Description	PIN NO.	Description
1	TX-	2	TX+
3	RX+	4	RX-
5	GND	6	NC
7	NC	8	NC
9	NC	10	+5V

- Note: 1. CC2 (COM2) for RS422/485 Option function
 2. BIOS need setting to RS485 mode
 3. ALL COM port wafer 2.0mm connector pin 10 provide +5V

3-5 Front Panel connector

● CFP1 FP connector (2x5pin 2.0mm wafer)

PIN NO.	Description	PIN NO.	Description
1	Power button pin	2	Power button GND
3	Reset pin	4	Reset GND
5	Power LED -	6	Power LED +
7	HDD LED-	8	HDD LED+
9	LAN LED-	10	LAN LED+

Note : 1. LED1 is power LED (Green)

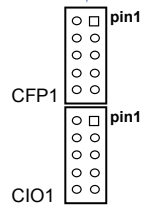

3-6 Digital Input / Output / Watch Dog Time

● CIO1 DIO 0-3 (2x5pin 2.0mm wafer)

PIN NO.	Description	PIN NO.	Description
1	DI-0	2	DO-3
3	DI-1	4	DO-2
5	DI-2	6	DO-1
7	DI-3	8	DO-0
9	GND	10	+5V

Note: 1. All DI-0~3 external pull Hi 10KΩ to +V5S

2. If want connect to out side device, suggest use Isolator component like photo coupler or Relay.

For F75111N I²C watch dog timer device:

DC spec :

Input low Voltage (VIL):+0.8 Max ,

Input High Voltage(VIH) : +2V Min

Output low Current (IOL):10mA (Min) VOL=0.4V

Output High Current (IOH):-10mA (Min) VOL=2.4V

Watch Dog Time value 0~255 sec

The system will be issued reset. When WDT is enable the hardware start down counter to zero.

The reset timer have 10~20% tolerance upon the Temperature.

Note: Please refer to “ Manual ” for sample code for detail description

3-6-1 IO Device:F75111 under DOS

The Sample code source you can download from

Source file: F75111_Dos_Src.rar http://tprd.info/lexwiki/index.php/IO_Device:F75111_under_DOS

Binary file: F75111_Dos_Bin.rar

USERNAME & PASSWORD: sf

How to use this Demo Application

- 1.Boot Ms-Dos Operating System
- 2.execute "75WDT.EXE" binary file
- 3.Input 1 to Enable WDT timer or input 0 to Disable it.
- 4.input numbers of second for chip countdown and Reset Computer

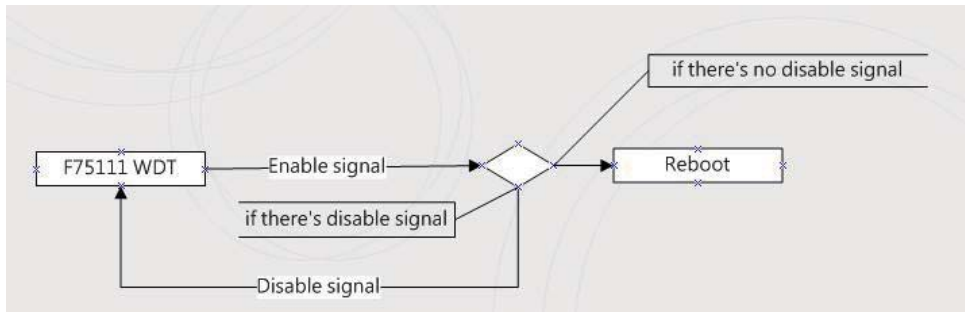

Introduction

Enable Watch Dog Timer

```
Writel2CByte(I2CADDR, CONFIG, 0x03);//Set Watch Dog Timer function
Writel2CByte(I2CADDR, WDT_TIMER, timer);//Set Watch Dog Timer range from 0-255.
Writel2CByte(I2CADDR, WDT_TIMER_CTL, 0x73);//Enable Watch Dog Timer in second and pulse mode
```

Disable Watch Dog Timer

```
Writel2CByte(I2CADDR, WDT_TIMER_CTL, 0x00);
```

Time Pause for mini seconds

```
void pause(int time)
{
    asm mov ah,0h;           //Ah = 00 Read System Time Counter
    asm int 1ah;           //read time from Time Counter and store it in DX register
    asm add dx,time;
    asm mov bx,dx;
    label:
    asm int 1ah;
    asm cmp bx,dx;
    asm jne label;
}
```

3-6-2 IO Device: F75111 under Windows

The Sample code source you can download from



Source file: F75111_DIOSrc.rar http://tprd.info/lexwiki/index.php/IO_Device:F75111

Binary file: F75111_DemoBin.rar

USERNAME & PASSWORD: sf

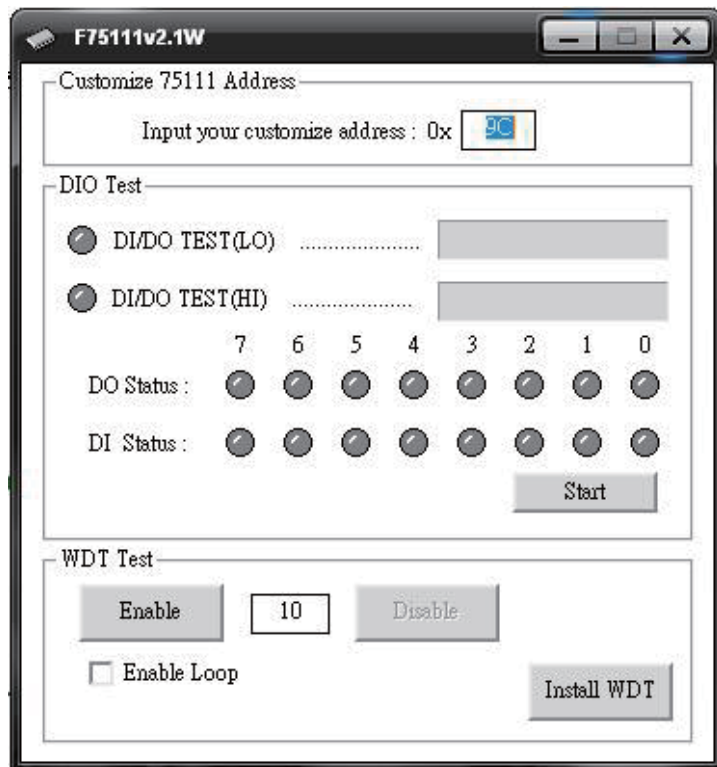
How to use this Demo Application



1. Press the "Start" button to test DIO function
2. Press the "Enable" button to test WDT function
3. Press the "Disable" button to disable WDT
4. Check the "Enable Loop" box and press "Enable" to do WDT loop test
5. Press "Install WDT" to set the system to autorun this application when booting, press again to remove this application when booting.
6. If WDT enable, system icon will be  . if disable, system icon will be 

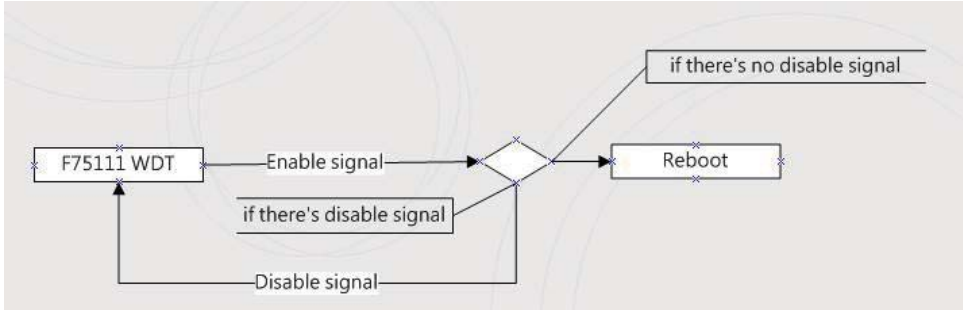

p.s.
 f75111 send "F75111_SetWDTEnable(BYTE byteTimer)" including a parameter "timer",
 if there's no disable signal (F75111_SetWDTDisable()) to stop it before timer countdown to 0, System will reboot.
 if there's disable signal received, resent Enable WDT signal, for a loop to prevent from reboot

Introduction

Initial Internal F75111 port address (0x9c)

```
define GPIO1X, GPIO2X, GPIO3X to input or output
and Enable WDT function pin
```

Set F75111 DI/DO (sample code as below Get Input value/Set output value)

```
DO: InterDigitalOutput(BYTE byteValue)
DI: InterDigitalInput()
```

Enable/Disable WDT

```
Enable : F75111_SetWDTEnable (BYTE byteTimer)
Disable: F75111_SetWDTDisable ()
```

PULSE mode

Sample to setting GP33, 32, 31, 30 output 1mS low pulse signal.

```
{
  this->Write_Byte(F75111_INTERNAL_ADDR, GPIO3X_PULSE_CONTROL,      0x00); //This is setting low pulse output
  this->Write_Byte(F75111_INTERNAL_ADDR, GPIO3X_PULSE_WIDTH_CONTROL, 0x01); //This selects the pulse width to 1mS
  this->Write_Byte(F75111_INTERNAL_ADDR, GPIO3X_CONTROL_MODE,       0x0F); //This is setting the GP33, 32, 31, 30 to output function.
  this->Write_Byte(F75111_INTERNAL_ADDR, GPIO3X_Output_Data ,      0x0F); //This is setting the GP33, 32, 31, 30 output data.
}
```

Initial internal F75111

```
void F75111::InitInternalF75111()
{
  this->Write_Byte(F75111_INTERNAL_ADDR,GPIO1X_CONTROL_MODE ,0x00); //set GPIO1X to Input function
  this->Write_Byte(F75111_INTERNAL_ADDR,GPIO3X_CONTROL_MODE ,0x00); //set GPIO3X to Input function
  this->Write_Byte(F75111_INTERNAL_ADDR,GPIO2X_CONTROL_MODE ,0xFF); //set GPIO2X to Output function

  this->Write_Byte(F75111_INTERNAL_ADDR,F75111_CONFIGURATION, 0x03); //Enable WDT OUT function
}
```

Set output value

```
void F75111::InterDigitalOutput(BYTE byteValue)
{
    BYTE byteData = 0;
    byteData = (byteData & 0x01 )? byteValue + 0x01 : byteValue;
    byteData = (byteData & 0x02 )? byteValue + 0x02 : byteValue;
    byteData = (byteData & 0x04 )? byteValue + 0x04 : byteValue;
    byteData = (byteData & 0x08 )? byteValue + 0x08 : byteValue;
    byteData = (byteData & 0x10 )? byteValue + 0x10 : byteValue;
    byteData = (byteData & 0x20 )? byteValue + 0x20 : byteValue;
    byteData = (byteData & 0x40 )? byteValue + 0x40 : byteValue;
    byteData = (byteData & 0x80 )? byteValue + 0x80 : byteValue;           // get value bit by bit

    this->Write_Byte(F75111_INTERNAL_ADDR,GPIO2X_OUTPUT_DATA,byteData); // write byteData value via GPIO2X output pin
}
}
```

Get Input value

```
BYTE F75111::InterDigitalInput()
{
    BYTE byteGPIO1X = 0;
    BYTE byteGPIO3X = 0;
    BYTE byteData   = 0;

    this->Read_Byte(F75111_INTERNAL_ADDR,GPIO1X_INPUT_DATA,&byteGPIO1X); // Get value from GPIO1X
    this->Read_Byte(F75111_INTERNAL_ADDR,GPIO3X_INPUT_DATA,&byteGPIO3X); // Get value from GPIO3X

    byteGPIO1X = byteGPIO1X & 0xF0;           // Mask unuseful value
    byteGPIO3X = byteGPIO3X & 0x0F;           // Mask unuseful value

    byteData = ( byteGPIO1X & 0x10 )? byteData + 0x01 : byteData;
    byteData = ( byteGPIO1X & 0x80 )? byteData + 0x02 : byteData;
    byteData = ( byteGPIO1X & 0x40 )? byteData + 0x04 : byteData;
    byteData = ( byteGPIO3X & 0x01 )? byteData + 0x08 : byteData;

    byteData = ( byteGPIO3X & 0x02 )? byteData + 0x10 : byteData;
    byteData = ( byteGPIO3X & 0x04 )? byteData + 0x20 : byteData;
    byteData = ( byteGPIO3X & 0x08 )? byteData + 0x40 : byteData;
    byteData = ( byteGPIO1X & 0x20 )? byteData + 0x80 : byteData;           // Get correct DI value from GPIO1X & GPIO3X

    return byteData;
}
}
```

Enable WatchDog

```
void F75111_SetWDTEnable (BYTE byteTimer)
{
    WriteByte(F75111_INTERNAL_ADDR,WDT_TIMER_RANGE ,byteTimer);           // set WatchDog range and timer
    WriteByte(F75111_INTERNAL_ADDR,WDT_CONFIGURATION,WDT_TIMEOUT_FLAG | WDT_ENABLE | WDT_PULSE | WDT_PSWIDTH_100MS);
                                                                           // Enable WatchDog, Setting WatchDog configure
}
}
```

Disable WatchDog

```
void F75111_SetWDTDisable ()
{
    WriteByte(F75111_INTERNAL_ADDR,WDT_CONFIGURATION,0x00);           // Disable WatchDog
}
```

3-6-3 IO Device: F75111 VB6 under Windows

The Sample code source you can download from

Source file: 75111_VB_v10.rar http://tprd.info/lexwiki/index.php/IO_Device:F75111_VB6

Binary file: 75111_VB_Src.rar

USERNAME & PASSWORD: sf

How to use this Demo Application

75111_DEMO VB v1.0

Please key-in the timer by sec !!

A **B**

 Enable WDT Disable WDT

Please key-in the DO Value by hex !! exp:0xFF = FF

 Set DO Value **C**

Push the Button will show the DI 1X_3X Value !!

D

Check DI Value 1X Value

 2X Value

A Function - Enable WDT timer ,Key-in the value by seconds then system will reboot after value which you key-in in left text box !!

B Function - Disable WDT timer ,Push down the button then WDT timer value will be clear !!

C Function - Set DO Value ,Key-in the DO value by hex then push the button !!

D Function - Check DI Value ,The right side two text box will display DI 1X & 2X Value when you push down the button!!

SDK Function Introduction

Function EnableWDT

Function EnableWDT(timer As Integer)

```
Call Writel2CByte(&H3, &H3)
Call Writel2CByte(&H37, timer)
Call Writel2CByte(&H36, &H73)
```

End Function

Function DisableWDT

Function DisableWDT()

```
Call Writel2CByte(&H36, &H0)
```

End Function

Function SetDOValue

Function SetDOValue(dovalue As Integer)

```
Call Writel2CByte(&H23, &H0)
Call Writel2CByte(&H20, &HFF)
Call Writel2CByte(&H2B, &HFF)
Call Writel2CByte(&H21, dovalue)
```

End Function

Function CheckDIValue

Function CheckDIValue()

```
Dim GPIO1X As Integer
Dim GPIO3X As Integer
Dim DI1Xhex As String
Dim DI3Xhex As String
```

```
Call Readl2CByte(&H12, GPIO1X)
Call Readl2CByte(&H42, GPIO3X)
```

```
DI1Xhex = Hex(GPIO1X)
DI3Xhex = Hex(GPIO3X)
```

```
Text3.Text = "0x" + DI1Xhex
Text4.Text = "0x" + DI3Xhex
```

End Function

3-6-4 IO Device: F75111 under linux

The Sample code source you can download from

Source file: F75111v2.0L.tar.gz http://tprd.info/lexwiki/index.php/IO_Device:F75111_under_linux

Binary file: F75111v2.0LBin.tar.gz

USERNAME & PASSWORD: sf

How to compile source code

1. Compile source code with Code::Blocks

download and install the Code::Block with command "apt-get install codeblocks"

Open an exist project(F75111.cbp) in Code::Blocks, click the compile button

(add an option 'pkg-config --libs gtk+-2.0 gthread-2.0' in "Project->Build Option->Linker Setting->Other linker option")

2. Compile source code with "make"

1.cd F75111

1.make

1.src/f75111 // execute the binary file

How to use this Demo Application



1. Press the "Start" button to test DIO function
2. Press the "Enable" button to test WDT function
3. Press the "Disable" button to disable WDT
4. Check the "Enable Loop" box and press "Enable" to do WDT loop test
5. Press "Install" to set the system to autorun this application when booting, press "Uninstall" to remove this application when booting.
6. If WDT enable, system icon will be blinking.

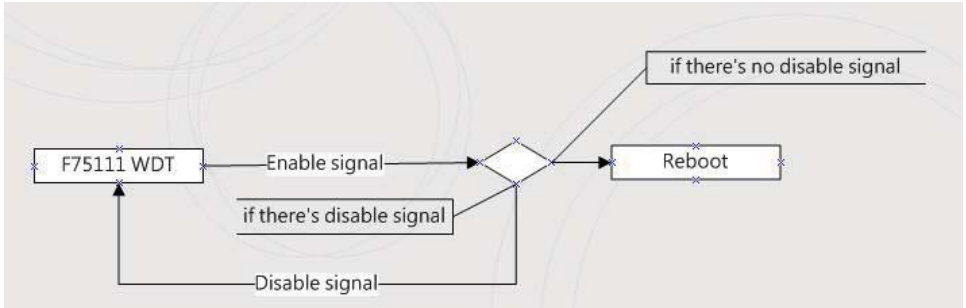

p.s.
 f75111 send "F75111_SetWDTEnable(BYTE byteTimer)" including a parameter "timer",
 if there's no disable signal (F75111_SetWDTDisable()) to stop it before timer countdown to 0, System will reboot.
 if there's disable signal received, resent Enable WDT signal, for a loop to prevent from reboot

Introduction

IO function In file SMBus.c

```

void SMBusIoWrite(BYTE byteOffset,BYTE byteData)
{
    outb( byteData , m_SMBusMapIoAddr + byteOffset);
}

BYTE SMBusIoRead(BYTE byteOffset)
{
    DWORD dwAddrVal;

    dwAddrVal = inb(m_SMBusMapIoAddr + byteOffset);
    return (BYTE)(dwAddrVal & 0x0FF);
}
  
```

Initial internal F75111

```

void F75111::InitInternalF75111()
{
    this->Write_Byte(F75111_INTERNAL_ADDR,GPIO1X_CONTROL_MODE ,0x00); //set GPIO1X to Input function
    this->Write_Byte(F75111_INTERNAL_ADDR,GPIO3X_CONTROL_MODE ,0x00); //set GPIO3X to Input function
    this->Write_Byte(F75111_INTERNAL_ADDR,GPIO2X_CONTROL_MODE ,0xFF); //set GPIO2X to Output function

    this->Write_Byte(F75111_INTERNAL_ADDR,F75111_CONFIGURATION, 0x03); //Enable WDT OUT function
}
  
```

Set output value

```
void F75111::InterDigitalOutput(BYTE byteValue)
{
    BYTE byteData = 0;
    byteData = (byteData & 0x01 )? byteValue + 0x01 : byteValue;
    byteData = (byteData & 0x02 )? byteValue + 0x02 : byteValue;
    byteData = (byteData & 0x04 )? byteValue + 0x04 : byteValue;
    byteData = (byteData & 0x08 )? byteValue + 0x08 : byteValue;
    byteData = (byteData & 0x10 )? byteValue + 0x10 : byteValue;
    byteData = (byteData & 0x20 )? byteValue + 0x20 : byteValue;
    byteData = (byteData & 0x40 )? byteValue + 0x40 : byteValue;
    byteData = (byteData & 0x80 )? byteValue + 0x80 : byteValue;           // get value bit by bit

    this->Write_Byte(F75111_INTERNAL_ADDR,GPIO2X_OUTPUT_DATA,byteData); // write byteData value via GPIO2X output pin
}
}
```

Get Input value

```
BYTE F75111::InterDigitalInput()
{
    BYTE byteGPIO1X = 0;
    BYTE byteGPIO3X = 0;
    BYTE byteData = 0;

    this->Read_Byte(F75111_INTERNAL_ADDR,GPIO1X_INPUT_DATA,&byteGPIO1X); // Get value from GPIO1X
    this->Read_Byte(F75111_INTERNAL_ADDR,GPIO3X_INPUT_DATA,&byteGPIO3X); // Get value from GPIO3X

    byteGPIO1X = byteGPIO1X & 0xF0;           // Mask unuseful value
    byteGPIO3X = byteGPIO3X & 0x0F;           // Mask unuseful value

    byteData = ( byteGPIO1X & 0x01 )? byteData + 0x01 : byteData;
    byteData = ( byteGPIO1X & 0x08 )? byteData + 0x02 : byteData;
    byteData = ( byteGPIO1X & 0x40 )? byteData + 0x04 : byteData;
    byteData = ( byteGPIO3X & 0x01 )? byteData + 0x08 : byteData;

    byteData = ( byteGPIO3X & 0x02 )? byteData + 0x10 : byteData;
    byteData = ( byteGPIO3X & 0x04 )? byteData + 0x20 : byteData;
    byteData = ( byteGPIO3X & 0x08 )? byteData + 0x40 : byteData;
    byteData = ( byteGPIO1X & 0x20 )? byteData + 0x80 : byteData;           // Get correct DI value from GPIO1X & GPIO3X

    return byteData;
}
}
```

Enable WatchDog

```
void F75111_SetWDTEnable (BYTE byteTimer)
{
    WriteByte(F75111_INTERNAL_ADDR,WDT_TIMER_RANGE ,byteTimer);           // set WatchDog range and timer
    WriteByte(F75111_INTERNAL_ADDR,WDT_CONFIGURATION,WDT_TIMEOUT_FLAG | WDT_ENABLE | WDT_PULSE | WDT_PSWIDTH_100MS);
                                                                           // Enable WatchDog, Setting WatchDog configure
}
```

Disable WatchDog

```
void F75111_SetWDTDisable ()
{
    WriteByte(F75111_INTERNAL_ADDR,WDT_CONFIGURATION,0x00);           // Disable WatchDog
}
```

3-7 Touch screen device

CT1: Touch screen (2x5 pin 2.0mm wafer)
Default use USB6 interface.

- **For 8- wire type pin define**

PIN NO.	Description	PIN NO.	Description
1	Bottom	2	Bottom Sense
3	Top Sense	4	Top
5	Right	6	Right Sense
7	Left	8	Left Sense
9	GND	10	NC

Note: For eight wire type cable Pin 3 and Pin4 need short.

- **For 4- wire type pin define**

PIN NO.	Description	PIN NO.	Description
1	Bottom	2	N/A
3	N/A	4	Top
5	Right	6	N/A
7	Left	8	N/A
9	GND	10	KEY

Note: For four wire type cable Pin 3 and Pin4 need short.

- **For 5- wire type pin define**

PIN NO.	Description	PIN NO.	Description
1	UR(H)	2	N/A
3	Sense	4	UL(Y)
5	LR(X)	6	N/A
7	LL(L)	8	N/A
9	GND	10	KEY

3-8 I²C Bus Interface

- **CO1:I²C Bus 4pin (1.25mm)Wafer**

PIN NO.	Description
1	+3.3V
2	GND
3	I ² C CLK
4	I ² C DATA

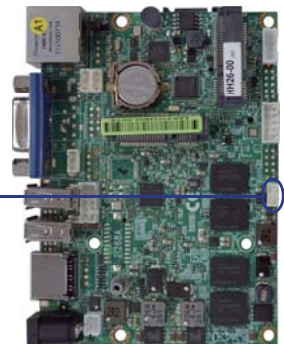
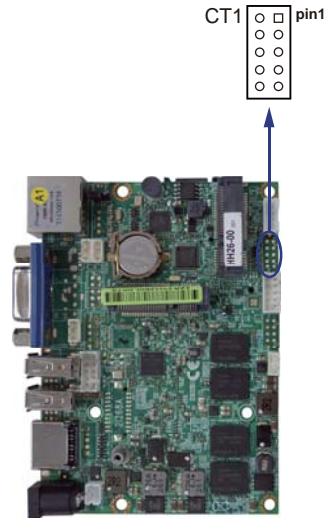
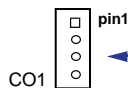

3-9 DC -IN power connector

- **CPI1 : DC 12V-in power Jack**

PIN NO.	Description
1	+12V DC-IN
2,3	GND

Note: Very important check Dc-in Voltage



- **CPI12 : DC-in 1x2 (2.0mm)Wafer Internal connector**

PIN NO.	Description
1	DC-IN(12V)
2	GND

Note: Very important check DC-in Voltage

- **CPI11 : DC 12V-in Internal connector (4pin ATX power 4.20mm) (Option)**

PIN NO.	Description
1,2	GND
3,4	+12V DC-IN

Note: Very important check DC-in Voltage
CPI11 share with CPI1 position.

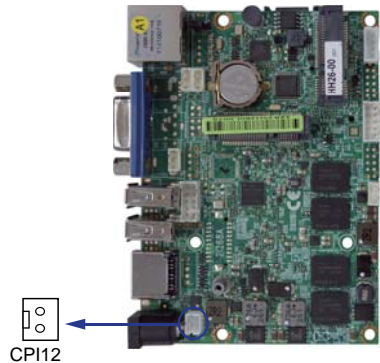

3-10 CMOS battery connector

- BAT1 : 3V Battery hold 2pin**

- BAT1 : Batter use Li 3V / 40mAh (CR1220)**

**Note : 1. When board without Adaptor plug in, this board power RTC consumption 2.7uA
2. If adaptor always plug in RTC power consumption 0.1uA**

- **CBT1: 3V Battery 2pin(1.25mm)Wafer (option)**

PIN NO.	Description
1	CATHODE(-)
2	ANOD(+)

Note : 1. This connector for external 3V Li battery use.
2. CBT1 can work with BAT1 same time.
3. Li battery can use CR2032 type 3V / 220mAh

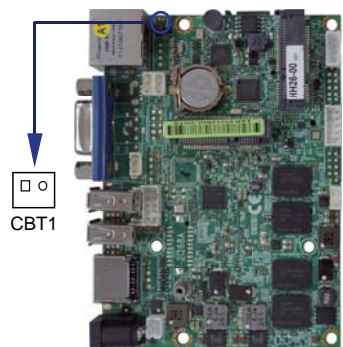

3-11 LAN port

- **CL1: LAN port Giga /100Mb(RJ45 Jack)**

PIN NO	Description	PIN NO.	Description
1	TR0-/TX+	5	TR2-/NC
2	TR0+/TX-	6	TR2+/RX-
3	TR1-/RX+	7	TR3-/NC
4	TR1+/NC	8	TR3+/NC

- **CL1 : LAN1 port Giga /100Mb(2x4pin 2.0mm wafer) (Option)**

PIN NO	Description	PIN NO.	Description
1	TR0+ / TX+	2	TR0- / TX-
3	TR1+ / RX+	4	TR1- / RX-
5	TR2+ / NC	6	TR2- / NC
7	TR3+ / NC	8	TR3- / NC

Note: RJ45 share with Wafer 2x4 connector



LAN LED

RTL 8111F

Speed	10 Mbps			100 Mbps			1000 Mbps		
	Back Side		Fornt Side	Back Side		Fornt Side	Back Side		Fornt Side
Indicate	Link Led	ACT Led	ACT Led	Link Led	ACT Led	ACT Led	Link Led	ACT Led	ACT Led
	LAN light		Orange	Orange	Green	Orange	Orange	Orange	Orange

3-12 USB Ports

• CU1/2/3/4 : USB 1/2/3/4 ports (USB Type A connector)

PIN NO.	Description
1	+5V
2	USB DATA -
3	USB DATA +
4	GND

Note: 1. CU1/2 connector share with DVI
 2. CU3/4 connector share with CC1/CG1/CA1

Internal USB connector (4pin 1.25mm Wafer)

- CU11/CU21: USB 1/2 ports
- CU31/CU41: USB 3/4 ports
- CU5:USB5 ports

PIN NO.	Description
1	+5V
2	USB DATA -
3	USB DATA +
4	GND

Note : 1. Attention ! Check Device Power in spec
 2. CU11 share CU1 , CU21 share CU2
 3. CU31 share CU3 , CU41 share CU4

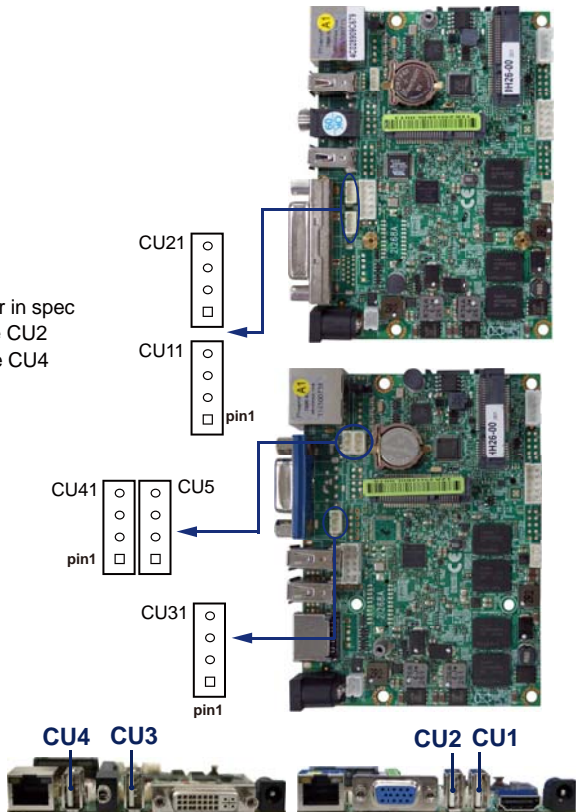

3-13 DC +5 / +12V Voltage output connector

- CPO1: +12V / +5V DC voltage output (4pin 2.0mm Wafer)

PIN NO.	Description
1	+5V
2	GND
3	GND
4	+12V *

Note : 1. Attention ! Check Device Power in spec
 2. +12V from Adapter in (same as Adaptor voltage)

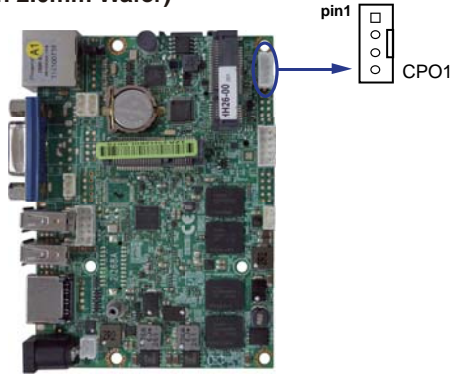

3-14 SATA Interface

- SATA1: SATA connector (7pin wafer)

PIN NO.	Description
1	GND
2	DATA TX+
3	DATA TX-
4	GND
5	DATA RX-
6	DATA RX+
7	GND

Note : 1. CPO1 provide SATA HDD power

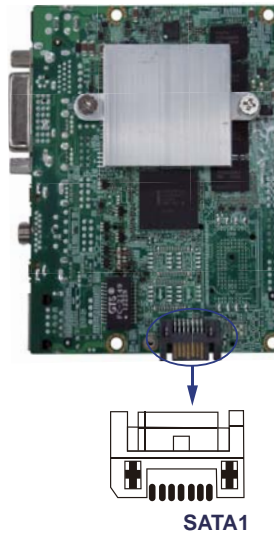

3-15 Mini and SIM card

- **MPCE1** : Full size mini card (Mini card socket 52pin)
- **MPCE2** : Half size mini card (Mini card socket 52pin)
- **SIM1** : SIM card reader socket

PIN NO.	Description	PIN NO.	Description
1	NC(Wake up)	2	+3.3V
3	NC	4	GND
5	NC	6	+1.5V
7	NC (CLKREQ-)	8	NC
9	GND	10	NC
11	PCIe-CLK-	12	NC
13	PCIe-CLK+	14	NC
15	GND	16	NC
KEY	KEY	KEY	KEY
17	NC	18	GND
19	NC	20	NC
21	GND	22	PRST-
23	PCIe-RX- / mSATA-RX+	24	+3.3V
25	PCIe-RX+ / mSATA-RX-	26	GND
27	GND	28	+1.5V
29	GND	30	SMB-CLK
31	PCIe-TX- / mSATA-TX-	32	SMB-DATA
33	PCIe-TX+ / mSATA-TX+	34	GND
35	GND	36	USB-DATA-
37	GND	38	USB-DATA+
39	+3.3V	40	GND
41	+3.3V	42	NC
43	NC	44	NC
45	NC	46	NC
47	NC	48	+1.5V
49	NC	50	GND
51	NC	52	+3.3V

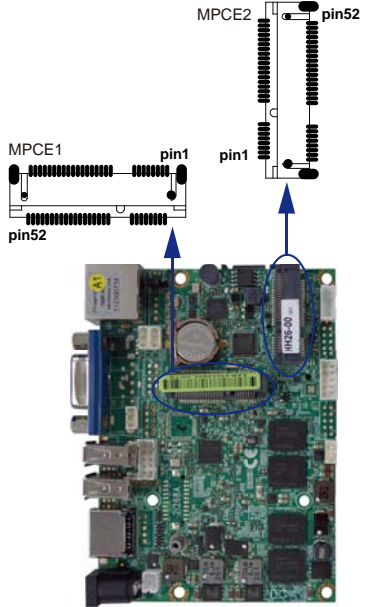

- Note:
1. MPCE1 : Default support USB / PCIe interface
 2. MPCE2 : Default support USB / mSATA , mSATA port share on board SSD driver
mSATA can change to PCIe function by OEM.
 3. SIM1 for SIM card reader socket provide for MPCE1 only.
SIM1 socket share with on board SSD

SIM1

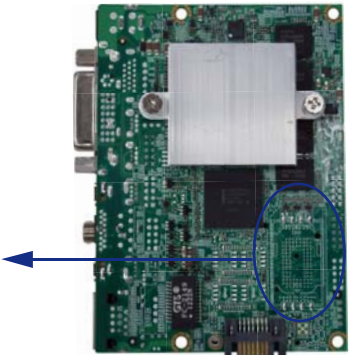
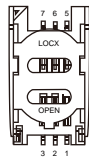

Chapter 4

Introduction of BIOS

The BIOS is a program located in the Flash Memory on the motherboard.

This program is a bridge between motherboard and operating system.

When you start the computer, the BIOS program gains control.

The BIOS first operates an auto-diagnostic test called POST (Power on Self Test) for all the necessary hardware, it detects the entire hardware devices and configures the parameters of the hardware synchronization. After these tasks are completed, BIOS will give control of the computer back to operating system (OS). Since the BIOS is the only channel for hardware and software to communicate with, it is the key factor of system stability and of ensuring your system performance at best.

In the BIOS Setup main menu, you can see several options. We will explain these options in the following pages. First, let us see the function keys you may use here:

Press <Esc> to quit the BIOS Setup.

Press ↑↓←→(up, down, left, right) to choose the option you want to confirm or modify.

Press <F10> to save these parameters and to exit the BIOS Setup menu after you complete the setup of BIOS parameters.

Press Page Up/Page Down or +/- keys to modify the BIOS parameters for the active option.

4-1 Enter Setup

Power on the computer and press key immediately to enter Setup.

If the message disappears before your respond but you still wish to enter Setup, restart the system by turning it OFF then ON. You may also restart the system by simultaneously pressing <Ctrl>, <Alt> and <Delete> keys.

4-2 Getting Help

Main Menu

The on-line description of the highlighted setup function is displayed at the bottom of the screen.

Status Page Setup Menu/ Option Page Setup Menu

Press F1 to pop up a small help window that describes the appropriate keys to use and the possible selections for the highlighted item.

To exit the Help Window, press <Esc>.

4-3 The Main Menu

Once you enter Award BIOS CMOS Setup Utility, the Main Menu will appear on the screen. The Main Menu has ten setup functions and two exit choices. Use arrow keys to select among these items. Press <Enter> to accept or enter the sub-menu.

Phoenix-AwardBIOS CMOS Setup Utility

▶ Standard CMOS Features	▶ PC Health Status
▶ Advanced BIOS Features	Load Optimized Defaults
▶ Advanced Chipset Features	Set Supervisor Password
▶ Integrated Peripherals	Set User Password
▶ Power Management Setup	Save & Exit Setup
▶ PnP/PCI Configurations	Exit Without Saving
Esc : Quit	↑ ↓ → ← : Select Item
F10 : Save & Exit Setup	
Time, Date, Hard Disk Type...	

Standard CMOS Features

This Menu is for basic system configurations.

Advanced BIOS Features

This menu is to set the Advanced Features available in your system.

Advanced Chipset Features

This menu is to change the values in the chipset registers and optimize your system performance.

Integrated Peripherals

This menu is to specify your settings for integrated peripherals.

Power Management Setup

This menu is to specify your settings for power management.

PnP/PCI configurations

This entry appears if your system supports PnP/PCI.

PC Health Status

This entry shows your PC health status.

Load Optimized Defaults

Use this menu to load the BIOS default values for optimal system performances.

Set Supervisor/User Password

This menu is to set User and Supervisor Passwords.

Save & Exit Setup

Save CMOS values modified to CMOS and exit setup.

Exit Without Saving

Abandon all the CMOS values modified and exit setup.

4-4 Standard CMOS Features

The items in Standard CMOS Setup Menu are divided into several categories. Each category includes none, one or more than one setup items. Use the arrow keys to highlight the item and then use the <PgUp> or <PgDn> keys to select the value you want to modify with this item.

Phoenix - AwardBIOS CMOS Setup Utility
Standard CMOS Features

Date (mm:dd:yy)	Tue, Nov 6 2012	Item Help
Time (hh:mm:ss)	0 : 0 : 0	
▶ IDE Channel 0 Master	[None]	Menu Level >
▶ IDE Channel 1 Master	[None]	Change the day, month, year and century
Video	[EGA/VGA]	
Halt On	[No Errors]	
Base Memory	640K	
Extended Memory	1038336K	
Total Memory	1039360K	
↑ ↓ → ← : Move Enter: Select +/-/PU/PD: Value F10: Save ESC: Exit F1: General Help F5: Previous Values F6: Fail-Safe Defaults F7: Optimized Defaults		

IDE Primary/Secondary Master

Press PgUp/<+> or PgDn/<-> to select Manual, None, Auto type. Note that the specifications of your drive must match with the drive table. The hard disk will not work properly if you enter improper information for this category. If your hard disk drive type is not matched or listed, you can use Manual to define your own drive type manually. If you select Manual, related information is asked to be entered to the following items. Enter the information directly from the keyboard. This information should be provided in the documentation from your hard disk vendor or the system manufacturer.

Video

The setting controls the type of video adapter used for the primary monitor of the system. Settings are: EGA/VGA (default), CGA 40, CGA 80 and Mono.

Halt On

The setting determines whether the system will stop if an error is detected at boot. Settings are:

All Errors:	The system stops when any error is detected.
No Errors (default):	The system doesn't stop for any detected error.
All, But Keyboard:	The system doesn't stop for a keyboard error.

4-5 Advanced BIOS Features

Phoenix - AwardBIOS CMOS Setup Utility Advanced BIOS Features

▶ Hard Disk Boot Priority	[Press Enter]	Item Help
▶ USB Boot Priority	[Press Enter]	
Virus Warning	[Disabled]	Menu Level >
Hyper-Threading Technology	[Enabled]	
Quick Power On Self Test	[Enabled]	
First Boot Device	[USB-FDD]	
Second Boot Device	[CDROM]	
Third Boot Device	[Hard Disk]	
Boot Other Device	[Enabled]	
Boot Up NumLock Status	[On]	
Gate A20 Option	[Fast]	
Typematic Rate Setting	[Disabled]	
x Typematic Rate <Chars/Sec>	6	
x Typematic Delay <Msec>	250	
OS Select For DRAM > 64MB	[Non-OS2]	
HDD S.M.A.R.T Capability	[Disabled]	
Full Screen LOGO Show	[Enabled]	
Small Logo<EPA> Show	[Disabled]	
↑ ↓ → ← : Move Enter : Select +/- / PU / PD : Value F10 : Save ESC : Exit F1 : General Help F5 : Previous Values F6 : Fail-Safe Defaults F7 : Optimized Defaults		

Hard Disk Boot Priority

Please refer section 4-5-1

USB Boot Priority

Please refer section 4-5-2

Virus Warning

The Virus Warning feature can help you protect IDE Hard Disk boot sector.

If this function is enabled, BIOS will show a warning message on screen and alarm beep when someone attempts to write data into this area without permission.

Disabled No warning message appears when anything attempts to access the boot sector or hard disk partition table.

Enabled (default) Activate automatically when the system boots up. The system will show the warning message if anything attempts to access the boot sector of hard disk partition table.

Hyper-Threading Technology

This item allows you to enable or disable Intel Hyper Threading technology.

Quick Power On Self Test

This category speeds up Power On Self Test (POST) after you power on the computer. If this is set to Enabled, BIOS will shorten or skip some check items during POST.

Enabled (default) Enable quick POST

Disabled Normal POST

First/Second/Third Boot Device

The BIOS attempts to load the operating system from the devices in the sequence selected in these items.

Settings are: Hard Disk, CDROM, USB-Device, USB-FDD, LAN and Disabled

Boot Other Device

Setting the option to Enabled allows the system to try to boot from other devices if the system fails to boot from the 1st/2nd/3rd boot device.

Boot Up NumLock Status

On (default) Keypad is numeric keys.

Off Keypad is arrow keys.

Gate A20 Option

Normal The A20 signal is controlled by keyboard controller or chipset hardware.

Fast (default) The A20 signal is controlled by port 92 or chipset specific method.

Typematic Rate Setting

Keystrokes repeat at a rate determined by the keyboard controller. When enabled, the typematic rate and typematic delay can be selected. The settings are: Enabled/Disabled.

Typematic Rate (Chars/Sec)

Sets the number of times a second to repeat a keystroke when you hold the key down.

Settings are: 6, 8, 10, 12, 15, 20, 24, and 30.

Typematic Delay (Msec)

Sets the delay time after the key is held down before it begins to repeat the keystroke.

Settings are 250, 500, 750, and 1000.

OS Select For DRAM > 64MB

Allows OS2 to be used with >64MB or DRAM. Settings are Non-OS/2 (default) and OS2.

Set to OS/2 if using more than 64MB and running OS/2

4-5-1 Hard Disk Boot Priority

Phoenix - AwardBIOS CMOS Setup Utility

Hard Disk Boot Priority

1. Ch1 S. :xxx-xxxxx 2. Ch2 P. :xxx-xxxxx 3. Bootable Add-in Cards	Item Help
	Menu Level ►
↑ ↓ → ← :Move Enter:Select +/-PU/PD:Value F10:Save ESC:Exit F1:General Help F5:Previous Values F6:Fail-Safe Defaults F7:Optimized Defaults	

Ch1 S/Ch2 P

It allows you to set the priority for hard disk boot. When you press enter, the selections shows the current hard disks used in your system

Bootable Add-in Cards

that is relevant to other boot sources media such as SCSI cards and LAN cards.

4-5-2 USB Boot Priority

Phoenix - AwardBIOS CMOS Setup Utility

USB Boot Priority

1. USB HDD0 : XXX-XXXXX 2. USB HDD1 : XXX-XXXXX	Item Help
	Menu Level ►
↑ ↓ → ← :Move Enter:Select +/-PU/PD:Value F10:Save ESC:Exit F1:General Help F5:Previous Values F6:Fail-Safe Defaults F7:Optimized Defaults	

USB HDD0/USB HDD1

It allows you to set the priority for USB storage boot. When you press enter, the selections shows the current USB storage used in your system

4-6 Advanced Chipset Features

The Advanced Chipset Features Setup option is used to change the values of the chipset registers. These registers control most of the system options in the computer.

Phoenix-AwardBIOS CMOS Setup Utility

Advanced Chipset Features

System BIOS Cacheable [Enabled]	Item Help
▶ PCI Express Root Port Func [Press Enter]	
** VGA Setting **	Menu Level ▶
On-Chip Fram Buffer Size [8MB]	
DVMT Mode [Enable]	
Total GFX Memory [128MB]	
Boot Display [Auto]	
Panel Number [1024 X 768 18bit]	
↑ ↓ → ← : Move Enter: Select +/-/PU/PD: Value F10: Save ESC: Exit F1: General Help	
F5: Previous Values F6: Fail-Safe Defaults F7: Optimized Defaults	

System BIOS Cacheable

Selecting Enabled allows caching of the system BIOS ROM at F0000h-FFFFFh, resulting in better system performance. However, if any program writes to this memory area, a system error may result.

Settings are: Enabled (default) and Disabled.

PCI Express Root Port Func

Please refer to section 4-6-1

On-chip Frame Buffer Size

This item allows you to select on-chip buffer size

The item choice: 1MB, 4MB, 8MB (default), 16MB, 32MB, 48MB, 64MB.

DVMT Mode

This item allows you to select the DVMT mode.

The choice: Enable (default), Disable

Total GFX Memory

This item allows you to select the graphics memory size.
The memory size choice: 128MB (default), 256MB, MAX.

Boot Display

This item allows you to select the display device.
Display Device: Auto (default), CRT, HDMI/DVI, LVDS, CRT+HDMI/DVI

Panel Number

This item allows you to select the panel resolution

1. 640 X 480 18bit
2. 800 X 600 18bit *
3. 1024 X 768 18bit * (default)
4. 800 X 480 18bit
5. 1024 X 600 18bit
6. 1280 X 800 18bit
7. 1366 X 768 18bit

4-6-1 PCI Express Root Port Func

Phoenix-AwardBIOS CMOS Setup Utility
PCI Express Root Port Func

PCI Express Port 1 [Auto]	Item Help
PCI Express Port 2 [Auto]	
PCI Express Port 3 [Auto]	Menu Level ►
PCI Express Port 4 [Auto]	
PCI-E Compliancy Mode [v1.0a]	
↑ ↓ → ← :Move Enter:Select +/-/PU/PD:Value F10:Save ESC:Exit F1:General Help F5:Previous Values F6:Fail-Safe Defaults F7:Optimized Defaults	

PCI Express Port 1/2/3/4

These items are Disabled, Enabled and Auto, the port 1 to port 4 of PCIe device.

Note: Port 1 to port 4 will all disables, if you select “Disable” on Port 1 item.

PCI-E Compliancy Mode

This item determines PCI Express bus in mode

- V1.0a** (default) it's compliant PCI Express in v1.0a specification.
V1.0 it's compliant PCI Express in v1.0 specification.

4-7 Integrated Peripherals

Phoenix-AwardBIOS CMOS Setup Utility
Integrated Peripherals

<pre> ▶ OnChip IDE Device [Press Enter] ▶ Super IO Device [Press Enter] ▶ USB Device Setting [Press Enter] </pre>	Item Help
	Menu Level >
<pre> ↑ ↓ → ← : Move Enter : Select + / - / PU / PD : Value F10 : Save ESC : Exit F1 : General Help F5 : Previous Values F6 : Fail-Safe Defaults F7 : Optimized Defaults </pre>	

OnChip IDE Device Function

Please refer to section 4-7-1

Super IO Device Function

Please refer to section 4-7-2

USB Device Setting

Please refer to section 4-7-3

4-7-1 OnChip IDE Device

Phoenix-AwardBIOS CMOS Setup Utility
OnChip IDE Device

<pre> IDE HDD Block Mode [Enabled] IDE DMA transfer access [Enabled] IDE Primary Master PIO [Auto] IDE Primary Master UDMA [Auto] On-Chip Secondary PCI IDE [Enabled] IDE Secondary Master PIO [Auto] IDE Secondary Master UDMA [Auto] SATA Mode [IDE] LEGACY Mode Support [Disabled] </pre>	Item Help
	Menu Level >>
<pre> ↑ ↓ → ← : Move Enter : Select + / - / PU / PD : Value F10 : Save ESC : Exit F1 : General Help F5 : Previous Values F6 : Fail-Safe Defaults F7 : Optimized Defaults </pre>	

IDE HDD Block Mode

Block mode is also called block transfer, multiple commands, or multiple sector read/write. If your IDE hard drive supports block mode (most new drives do), select Enabled for automatic detection of the optimal number of block read/writes per sector the drive can support. The settings are: Disabled, Enabled (default).

Primary/Secondary Master PIO

The IDE PIO (Programmed Input/Output) fields let you set a PIO mode (0-4) for IDE devices that the onboard IDE interface supports. Modes 0 through 4 provide successively increased performance. In Auto mode, the system automatically determines the best mode for each device.

The settings are: Auto (default), Mode 0, Mode 1, Mode 2, Mode 3 and Mode 4.

Primary/Secondary Master UDMA

Ultra DMA/33 implementation is possible only if your IDE hard drive supports it and the operating environment includes a DMA driver (Windows 95 OSR2 or a third-party IDE bus master driver) You're your hard drive and your system software both support Ultra DMA/33 and Ultra DMA/66, select Auto to enable BIOS support.

Settings are: Auto(default) , Disabled.

4-7-2 Super IO Device

Phoenix - AwardBIOS CMOS Setup Utility
Super IO Device

<pre> Onboard Serial Port 1 [3F8/IRQ4] COM1 422/485 flow control [Disabled] Onboard Serial Port 2 [2F8/IRQ3] COM2 422/485 flow control [Disabled] PWRON After PWR-Fail [Former-Sts] </pre>	Item Help Menu Level >>
<pre> ↑ ↓ → ← : Move Enter : Select + / - / PU / PD : Value F10 : Save ESC : Exit F1 : General Help F5 : Previous Values F6 : Fail-Safe Defaults F7 : Optimized Defaults </pre>	

Onboard Serial Port 1&2

Select an address and corresponding interrupt for the first and the second serial ports.

Settings are: 3F8/IRQ4, 2E8/IRQ3, 3E8/IRQ4, 2F8/IRQ3, Disabled, Auto.

COM1/2 422/485 flow control

This item allows you to disable or enable RS422 or RS485 function on COM 1/2, if you need.

PWRON After PWR-fail

This item specifies whether your system will reboot after a power failure or interrupt occurs.

Settings are: Off: Leaves the computer in the power off state.

On: Leaves the computer in the power on state.

Former-Sts: Restores the system to the status before power failure or interrupt occurred(Default).

4-7-3 USB Device Setting

Phoenix-AwardBIOS CMOS Setup Utility
USB Device Setting

USB 1.0 Controller	[Enabled]	Item Help
USB 2.0 Controller	[Enabled]	
USB Operation Mode	[High Speed]	
USB Keyboard Function	[Enabled]	Menu Level >>
USB Mouse Function	[Enabled]	
USB Storage Function	[Enabled]	

↑ ↓ → ← : Move Enter : Select + / - / PU / PD : Value F10 : Save ESC : Exit F1 : General Help
F5 : Previous Values F6 : Fail-Safe Defaults F7 : Optimized Defaults

USB 1.0 Controller

Select Enabled if your system contains a Universal Serial Bus (USB) controller and you have a USB peripherals.

Settings are: Enabled (default), Disabled.

USB 2.0 Controller

Select Enabled if your system contains a Enhanced Serial Bus (USB) controller and you have a USB peripherals.

Settings are: Enabled (default), Disabled.

USB Operation Mode

High speed:

If USB device was high speed device, then it operated on high speed mode. If USB device was full/low speed device, then it operated on full/low speed mode.

Full/Low Speed:

All of USB device operated on full/low speed mode.

USB Keyboard Function/ USB Mouse Function/USB Storage Function

Select Enabled if your system contains a Universal Serial Bus (USB) controller and you have a USB keyboard or USB mouse and USB storage.

Settings are: Enabled (default), Disabled.

4-8 Power Management Setup

The Power Management Setup allows you to configure your system to most effectively save energy saving while operating in a manner consistent with your own style of computer use.

Phoenix-AwardBIOS CMOS Setup Utility
Power Management Setup

<pre> ▶ PCI Express PM Function [Press Enter] ACPI Function [Enabled] ACPI Suspend Type [S1(POS)] Power Management [User Define] Video Off Method [DPMS] Video Off In Suspend [Yes] MODEM Use IRQ [3] Suspend Mode [Disabled] Soft-Off by PWR-BTN [Instant-Off] AT Mode Function [Disabled] Resume by Alarm [Disabled] x Date(of Month) Alarm 0 x Time(hh:mm:ss) Alarm 0 : 0 : 0 ** Reload Global Timer Events ** Primary IDE 0 [Disabled] Primary IDE 1 [Disabled] Secondary IDE 0 [Disabled] Secondary IDE 1 [Disabled] FDD,COM,LPT Port [Disabled] PCI PIRQ[A-D]# [Disabled] HPET Support [Enabled] HPET Mode [32-bit mode] </pre>	<table border="1" style="width: 100%; border-collapse: collapse;"> <tr> <td style="padding: 5px;">Item Help</td> </tr> <tr> <td style="padding: 5px;">Menu Level ></td> </tr> </table>	Item Help	Menu Level >
Item Help			
Menu Level >			
<p>↑ ↓ → ← : Move Enter : Select + / - / PU / PD : Value F10 : Save ESC : Exit F1 : General Help</p> <p>F5 : Previous Values F6 : Fail-Safe Defaults F7 : Optimized Defaults</p>			

PCI Express PM Function

Please refer to section 4-8-1

ACPI Function

This item allows you to Enabled/Disabled the Advanced Configuration and Power Management (ACPI).

Settings are: Enabled (default) and Disabled.

Video Off Method

This determines the manner in which the monitor is blanked.

- DPMS (default)** Initial display power management signaling.
- Blank Screen** This option only writes blanks to the video buffer.
- V/H SYNC+Blank** This selection will cause the system to turn off the vertical and horizontal synchronization ports and write blanks to the video buffer.

Video Off in Suspend

This determines the manner in which the monitor is blanked.

- Yes** Video will off.
- No** Video always On.

MODEM Use IRQ

This determines the IRQ in which the MODEM can use.

The settings are: 3(default), 4, 5, 7, 9, 10, 11, NA.

AT Mode Function

This item simulate AT action from power off by system.

If you need the function, the value "Former-Sts" should be change to "On" of PWRON After PWR-Fail of Super IO Device

The simulation procedure is:

1. Set the AT Mode function to Enabled
2. Set the PWRON After PWR-Fail to On under Super IO Device
3. Save and exit.
4. When Plug-in the power core, it will automatically turn on the system then boot in OS.
5. The system can not be power off, that will wake-up to turn on after power off when press shutdown bottom
6. To completely cut off power need plug out the power core.

Resume by Alarm

This function is for setting date and time for your computer to boot up. During Disabled, you cannot use this function. During Enabled, choose the Date and Time Alarm:

Date(of month) Alarm

You can choose which month the system will boot up. Set to 0, to boot every day.

Time(hh:mm:ss) Alarm

You can choose what hour, minute and second the system will boot up.

Note: If you have change the setting, you must let the system boot up until it goes to the operating system, before this function will work

4-8-1 PCI Express PM Function

Phoenix-AwardBIOS CMOS Setup Utility
PCI Express PM Function

▶ PCI Express PME [Disabled]	Item Help
	Menu Level ▶
↑ ↓ → ← : Move Enter : Select +/- / PU / PD : Value F10 : Save ESC : Exit F1 : General Help F5 : Previous Values F6 : Fail-Safe Defaults F7 : Optimized Defaults	

PCI Express PME

This item allows you to wake-up system, when PME event has presence.

4-9 PnP/PCI Configuration Setup

This section describes how to configure the PCI bus system. PCI, or Personal Computer Interconnect, is a system which allows I/O devices to operate at the speed the CPU itself keeps when CPU communicates with its own special components. This section covers some very technical items and we strongly recommended that only experienced users should make any change to the default settings.

Phoenix-AwardBIOS CMOS Setup Utility
PnP/PCI Configurations

Init Display First [PCI Slot]	Item Help
Reset Configuration Data [Disabled]	Menu Level ▶
Resources Controlled By [Auto (ESCD)]	
× IRQ Resources Press Enter	
PCI/VGA Palette Snoop [Disabled]	
↑ ↓ → ← : Move Enter : Select +/- / PU / PD : Value F10 : Save ESC : Exit F1 : General Help F5 : Previous Values F6 : Fail-Safe Defaults F7 : Optimized Defaults	

Reset Configuration Data

Normally, you leave this field Disabled. Select Enabled to reset Extended System Configuration

Data (ESCD) when you exit Setup if you have installed a new add-on and the system reconfiguration has caused such a serious conflict that the operating system can not boot. The settings are: Enabled and Disabled.

Resource Controlled By

The Award Plug and Play BIOS can automatically configure all of the boot and Plug and Play compatible devices. However, this capability means absolutely nothing unless you are using a Plug and Play operating system such as Windows 95/98. If you set this field to "manual", choose a specific resource by going into each sub menu that follows this field (a sub menu is preceded by a ">").

Settings are: Auto(ESCD) (default) or Manual.

IRQ Resources

Please refer section 4-9-1

PCI/VGA Palette Snoop

Leave this field at Disabled. The settings are Enabled or Disabled.

4-9-1 IRQ Resources

When resources are controlled manually, each system interrupt is assigned a type, depending on the type of device using the interrupt.

Phoenix-AwardBIOS CMOS Setup Utility

IRQ Resources

			Item Help
IRQ-3	assigned to	[PCI Device]	Menu Level ► Legacy ISA for devices compliant with the original PC AT bus specification, PCI/ISA PnP for devices compliant with the Plug and Play standard whether designed for PCI or ISA bus architecture.
IRQ-4	assigned to	[PCI Device]	
IRQ-5	assigned to	[PCI Device]	
IRQ-7	assigned to	[PCI Device]	
IRQ-9	assigned to	[PCI Device]	
IRQ-10	assigned to	[PCI Device]	
IRQ-11	assigned to	[PCI Device]	
IRQ-12	assigned to	[PCI Device]	
IRQ-14	assigned to	[PCI Device]	
IRQ-15	assigned to	[PCI Device]	
↑ ↓ → ← : Move Enter : Select +/- /PU/PD : Value F10 : Save ESC : Exit F1 : General Help			
F5 : Previous Values F6 : Fail-Safe Defaults F7 : Optimized Defaults			

4-10 PC Health Status

This section shows the status of your CPU, Fan, and overall system. This is only available when there is Hardware Monitor function onboard.

Phoenix-AwardBIOS CMOS Setup Utility
PC Health Status

VCC3V	3.31V	Item Help
Vcore	1.15V	Menu Level ►
VGFX	1.05V	
VBS3V	3.29V	
CPU Temp.	63°C	
System Temp.	43°C	
↑ ↓ → ← : Move Enter : Select +/- / PU / PD : Value F10 : Save ESC : Exit F1 : General Help		
F5 : Previous Values F6 : Fail-Safe Defaults F7 : Optimized Defaults		

Current CPU Temperature/Current System Temp Vcore/VGFX/VBS3V

This will show the CPU/Graphics/System voltage chart.

4-11 Load Optimized Defaults

When you press <Enter> on this item, you get a confirmation dialog box with a message similar to:

Load Optimized Defaults (Y/N)? N

Press <Y> to load the default values that are factory settings for optimal system operation performance.

4-12 Set Supervisor/ User Password

You can set supervisor password, user password, or both. The differences are:

Supervisor password: You can enter the setup menus and change the options.

User password: You can enter the setup menus but do not have the right to change the options. When you select this function, the following message will appear at the center of the screen to assist you in creating a password.

ENTER PASSWORD:

Type the password, up to eight characters in length, and press <Enter>. The password typed will clear any previous password from CMOS memory. You will be asked to confirm the password. Type the password again and press <Enter>. You may also press <Esc> to abort the selection without entering password. To disable a password, just press <Enter> when you are prompted to enter the password. A message will confirm if you want to disable the password. Once the password is disabled, the system will boot and you can enter Setup menus freely.

PASSWORD DISABLED.

When a password has been enabled, you have to enter it every time before you enter the Setup. This prevents an unauthorized person from changing any part of your system configuration.

Chapter 5

DRIVER INSTALLATION

There is a SYSTEM INSTALL CD disk in the package. This CD has all the drivers you need and some free application programs and utility programs. In addition, this CD also includes an auto-detect software which can tell you which hardware is installed and which driver is needed so that your system can function properly.

We call this auto detect software SYSTEM INSTALL.

SYSTEM INSTALL Supports WINDOWS Win7

Insert the CD into your CD-ROM drive and the SYSTEM INSTALL Menu should appear as below. If the menu does not appear, double-click MY COMPUTER and double-click CD-ROM drive or click START, click RUN, and type X:\SETUP.EXE (assuming X is your CD-ROM drive).

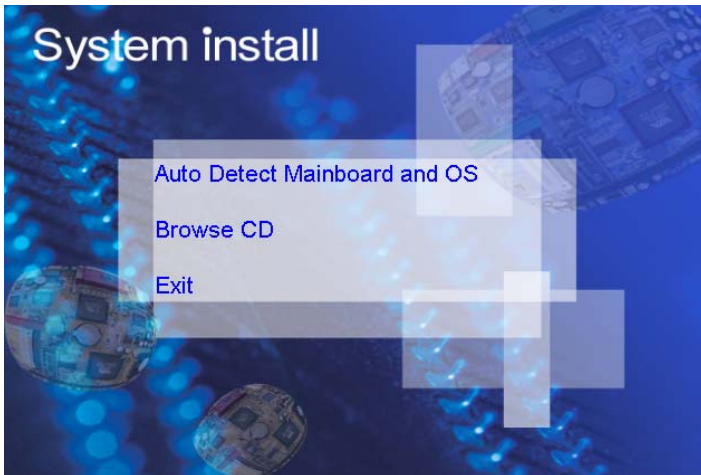

From SYSTEM INSTALL MENU you may make 3 selections:

- 1 . Auto detect main board and OS Into auto install driver Menu
- 2 . Explore CD to explore the contents of the CD
- 3 . EXIT to exit from SYSTEM INSTALL menu

5-1 INF Install Intel Cedarview Chipset Driver

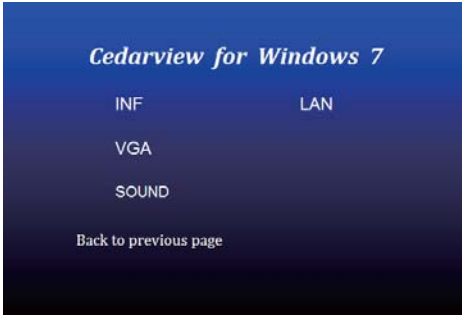

1. At the "AUTOMATIC DRIVER INSTALLATION menu" screen, click "INF".

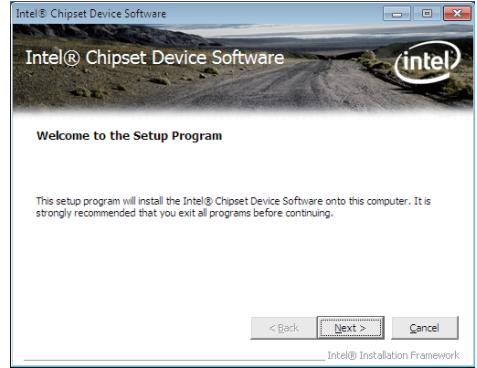

2. At the "Intel® Chipset Device Software" screen, click "Next".



3. At the "License Agreement" screen, click "Yes".

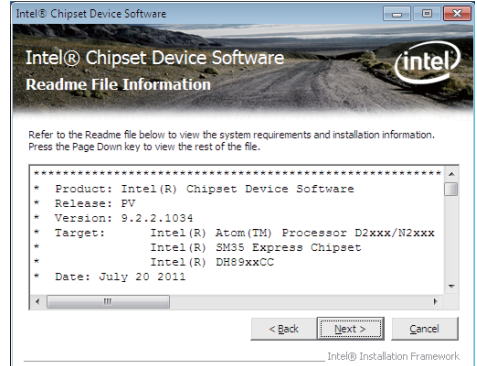

4. At the "Readme File Information" screen, click "Next".

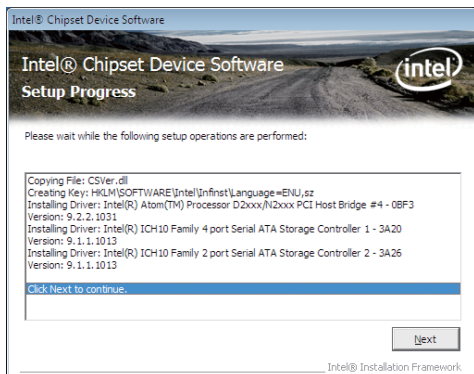

5. Click “Next”



6. Click “Finish” to restart computer.

NOTE: SYSTEM INSTALL will auto detect file path

X:\driver\INTEL\D2700\inf\infinst_autol.exe

This driver supports Windows XP 64/32-bit and Windows 7 64/32-bit.

5-2 VGA Install Intel Cedarview VGA Driver

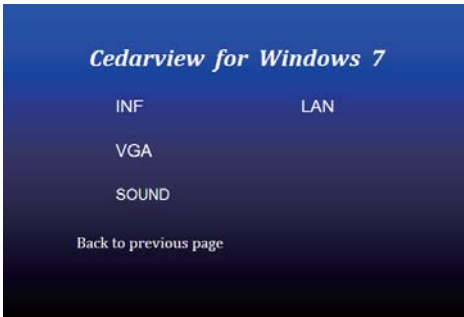

1. At the "AUTOMATIC DRIVER INSTALLATION menu" screen, click "VGA".

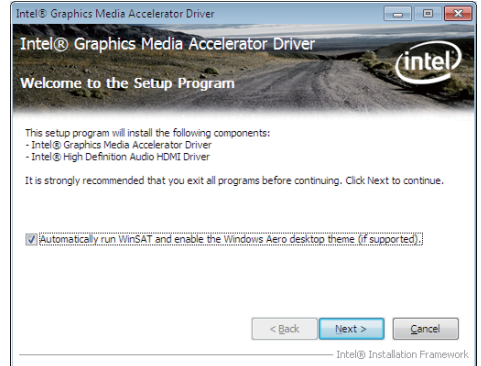

2. At the "Intel® Graphics Media Accelerator Driver" screen, click "Next".

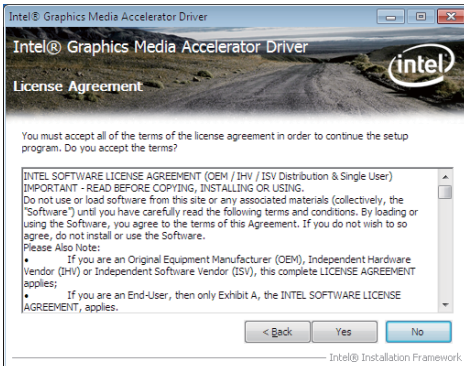

3. At the "License Agreement" screen, click "Yes".

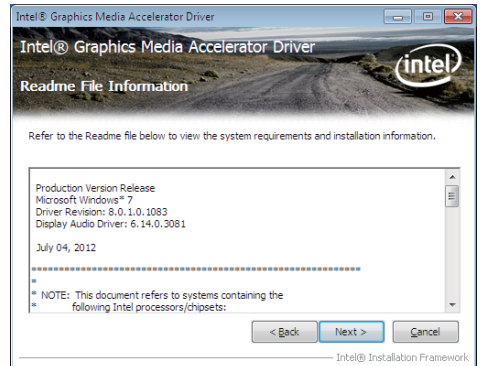

4. At the "Readme File Information" screen, Click "Next".

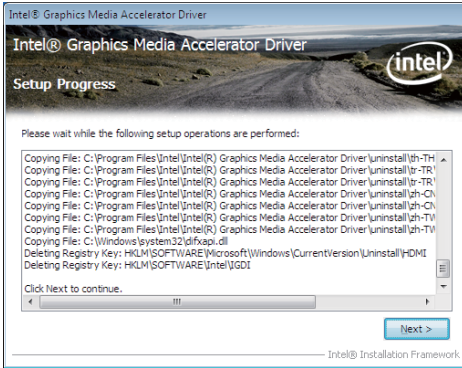

5. Click “Next”.

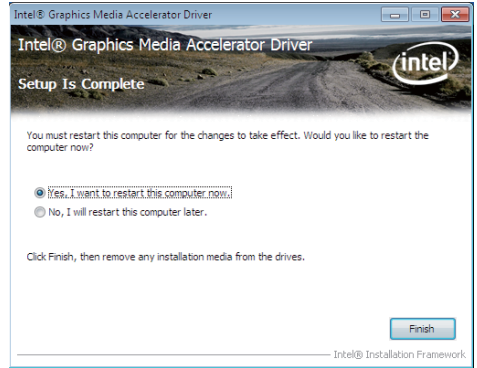

6. Click “Finish” to restart computer

NOTE: The path of the file

For WINDOWS 7 32-bit

x:\driver\INTEL\D2700\vga\Win7_32\Setup.exe

The Cedarview VGA driver does not supported Windows XP 32/64-bit and Windows 7 64-bit.

5-3 SOUND Install VIA HD Audio Codec Driver

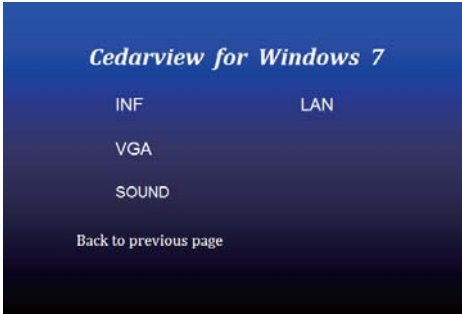

1. At the "AUTOMATIC DRIVER INSTALLATION menu" screen, click "SOUND".

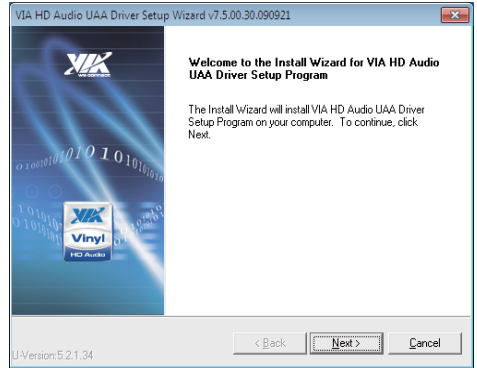

2. Click "Next".

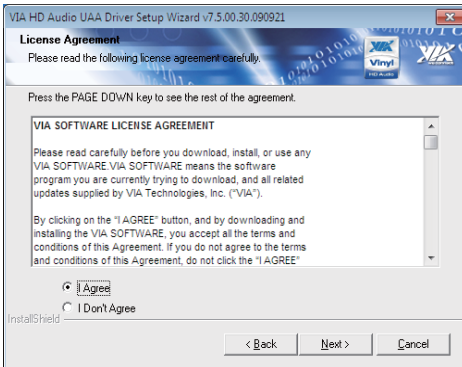

3. Click "Next".

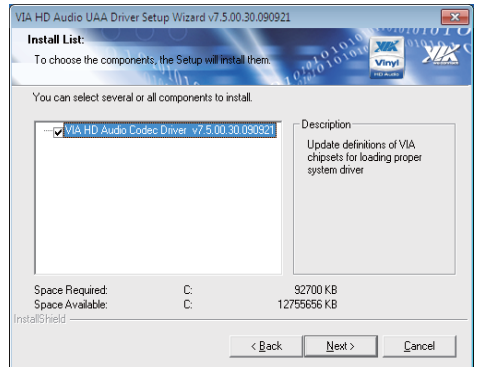

4. Click "Next" to install the driver. It might take a few minutes.

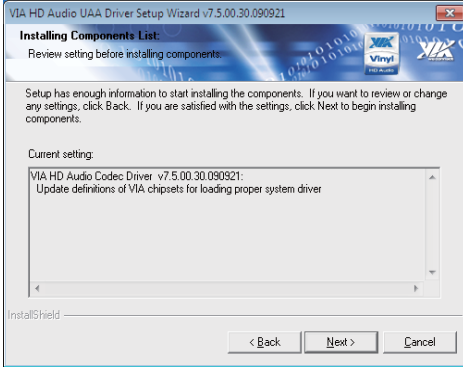

5. Click “Next”.

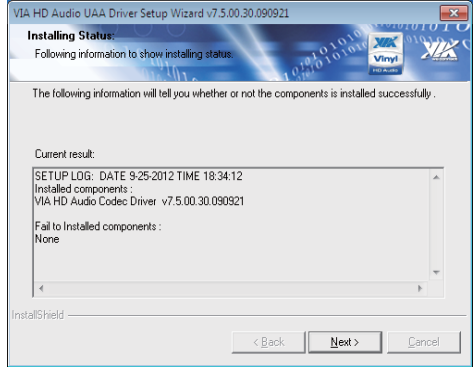

6. Click “Next”.

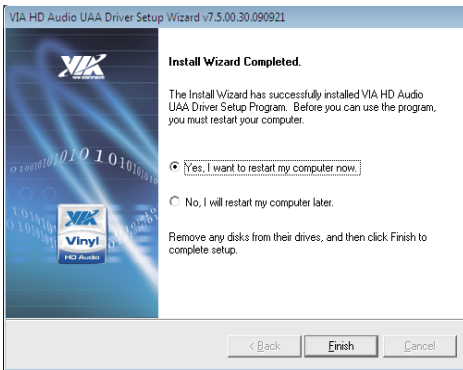

7. Click “Finish” to restart computer.

NOTE: The path of the file

For Windows XP 32/64 bit and Windows 7 32/64-bit

X:\driver\INTEL\I945\SOUND\VIAHDAudV7500a_Setup.exe

5-4 HOW TO UPDATE BIOS

Under DOS Mode

STEP 1. Prepare a bootable disc.

(Storage device could be USB FDD, CF card, or USB pen drive.)

STEP 2. Copy utility program to your bootable disc. You may copy it from DRIVER CD
X:\Dirver\bios\AWDFLASH.EXE or download it from our web site.

STEP 3. Copy the latest BIOS for your LEX motherboard from our web site to
your bootable disc.

STEP 4. (Here take 2I268C as an example,
please enter your motherboard's name)

Insert your bootable disc into X: (X could be C:, A: or others.

It depends on which type of storage device you use.)

Start the computer and type

X:\Awdflash 2I268Cxx.BIN /SN/PY/WB/CP/CD/CC/R

2I268Cxx.BIN is the file name of the latest BIOS.

It may be 2I268CA1.BIN or 2I268CA2.BIN, etc.

Please leave one space between .BIN & /SN/PY/WB/CP/CD/CC/R

By 2I268C series mainboard, pls type

X:\Awdflash 2I268Cxx.BIN /SN/PY/WB/CP/CD/CC/R

SN : don't save the current BIOS data

PY : renew the current BIOS data

WB : always programming Boot Block

CP : clear PnP(ESCD) data after programming

CD : clear DMI data after programming

CC : clear the current CMOS data

R : restart computer

STEP 5. Press ENTER and the BIOS will be updated,
Computer will restart automatically.

Appendix A: Power Consumption Test

Condition

Item	Spec
CPU	Intel Atom N2600 1.6GHz
SDRAM	DDR3 1300 / 2GB
Operating System	Windows 7 / SP1
Test Program	3D Mark Q3
HDD 3.5" SATA	Standard HDD
HDD 2.5" SATA	Slim Type HDD
mSATA	half size 32GB

Test Result for reference !

Hard Disk	Power off	Start up		Operation Maximum	Shut down Maximum
		Maximum	Stable		
Standard HDD	0.02A	2.47A	1.08A	1.37A	1.3A
Slim Type HDD	0.02A	0.88A	0.56A	0.89A	0.78A
mSATA	0.02A	0.73A	0.54A	0.75A	0.71A

The power consumption depends on your device choice!

Appendix B: Resolution list

800 x 600 x (256 / 16bit / 32bit)
1024 x 768 x (256 / 16bit / 32bit)
1152 x 864 x (256 / 16bit / 32bit)
1280 x 600 x (256 / 16bit / 32bit)
1280 x 720 x (256 / 16bit / 32bit)
1280 x 768 x (256 / 16bit / 32bit)
1280 x 800 x (256 / 16bit / 32bit)
1280 x 960 x (256 / 16bit / 32bit)
1280 x 1024 x (256 / 16bit / 32bit)
1400 x 1050 x (256 / 16bit / 32bit)
1440 x 900 x (256 / 16bit / 32bit)
1600 x 900 x (256 / 16bit / 32bit)
1600 x 1200 x (256 / 16bit / 32bit)
1680 x 1050 x (256 / 16bit / 32bit)
1920 x 1080 x (256 / 16bit / 32bit)
1920 x 1020 x (256 / 16bit / 32bit)