

- Clamps over voltage transients (up to 385 VDC) at 168 VDC
- Universal use: Can be used with any DC/DC converter
- Complies with RIA12, NF F 01-510 Surge susceptibilities
- Wide input voltage range: 43 – 160 VDC
- Brownout voltage 36 VDC min.
- Operating temperature range -40 to +95°C
- 3-year product warranty

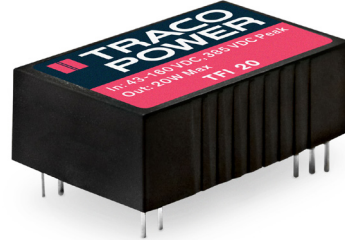

The new TFI 20 is a surge filter which comes in a compact DIP-24 plastic package. Placed in front of any DC/DC converter the TFI clamps momentary over-voltage transients to a safe value in order to protect the DC/DC converter from being damaged. During normal operation the output voltage follows the input voltage ($V_{out} = V_{in} - 2 \text{ VDC typ.}$) up to the point of 168 VDC where the voltage is actively clamped. Whereas the transients defined within the EN 50155 (up to 154 VDC) are covered by the wide input range of dedicated railway converters the TFI handles the stricter definition laid-out in the RIA12 standard which allows transients of up to 20ms at 385 VDC. This level of protection is specifically required in railway applications where high voltage transients are expected but can also be used for 72, 96 and 110 VDC battery systems in railway applications.

Models

Order code	Input voltage	Power max.
TFI 20	43 – 160 VDC	20 W

Input Specifications

Start-up Voltage		30 VDC max.
Transient Voltage	<ul style="list-style-type: none"> - 1 s max. - 100 ms max. - 20 ms max. 	165 VDC max. 176 VDC max. 385 VDC max.
Brownout		36 VDC min.

Output Specifications

Output Voltage		$V_{in} - 2$ VDC typ. / $V_{in} - 1$ VDC max.
Clamping Voltage	- Input Transient Voltage Mode	168 VDC typ.

General Specifications

Standards		RIA 12 Surge Susceptibility NF F 01-510 Surge Susceptibility
Case Material		Non-conductive black plastic
Base Material		Non-conductive black plastic
Potting Material		Silicone (UL94 V-0)
Weight		14 g
Temperature ranges	<ul style="list-style-type: none"> - Operating (without derating) - Case Temperature - Storage Temperature 	-40°C to +95°C +105°C max. -55°C to +125°C
Relative Humidity		95% max. (non condensing)
Thermal Shock		MIL-STD-810F
Vibration		MIL-STD-810F

Characeristic Curves

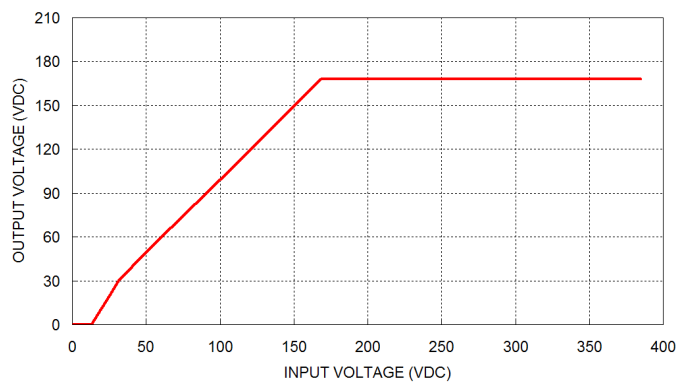

Transient Function

All specifications valid at nominal input voltage, full load and +25°C after warm-up time unless otherwise stated.

Possible Application

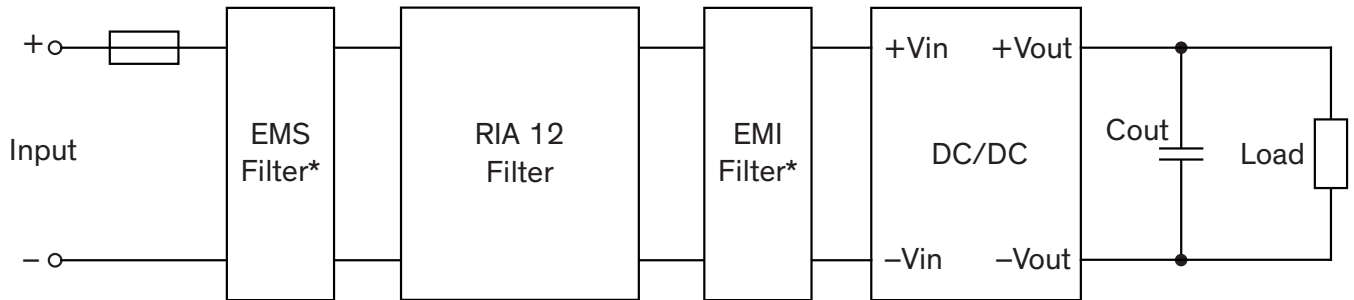

Schematic for typical application

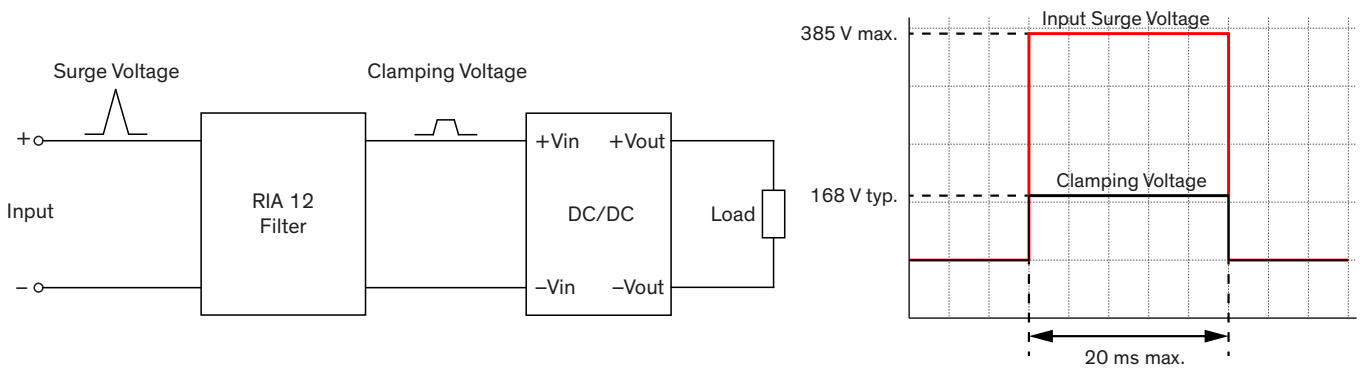

Input Surge Voltage vs. Clamping Voltage

The RIA 12 Filter clamps over-voltage to a safe value in order to protect the power module from damaging.

*Optional, depending on DC/DC converter.

All specifications valid at nominal input voltage, full load and +25°C after warm-up time unless otherwise stated.

Outline Dimensions

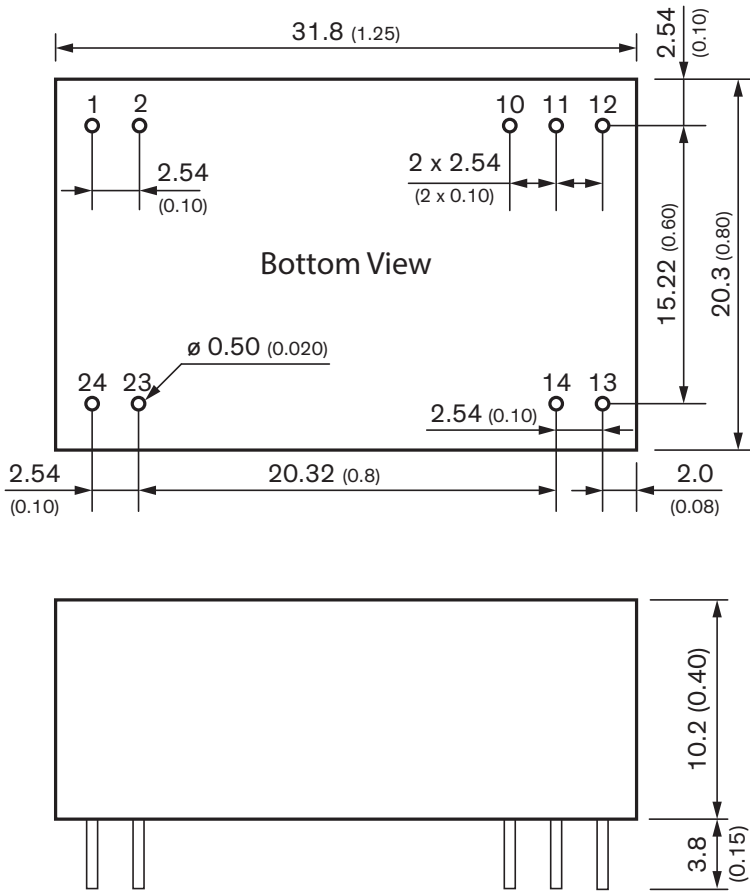

Pin-Out	
Pin	Function
1	+Vin
2	+Vin
10	+Vout
11	+Vout
12	+Vout
13	- Vout
14	- Vout
23	- Vin
24	- Vin

Dimensions in mm (Inch)

Tolerances: x.x ±0.5 (±0.02)

x.xx ±0.25 (±0.01)

Pin pitch tolerance ±0.25 (±0.01)

Pin dimension tolerance ±0.10 (±0.004)