

Schematic continues overleaf

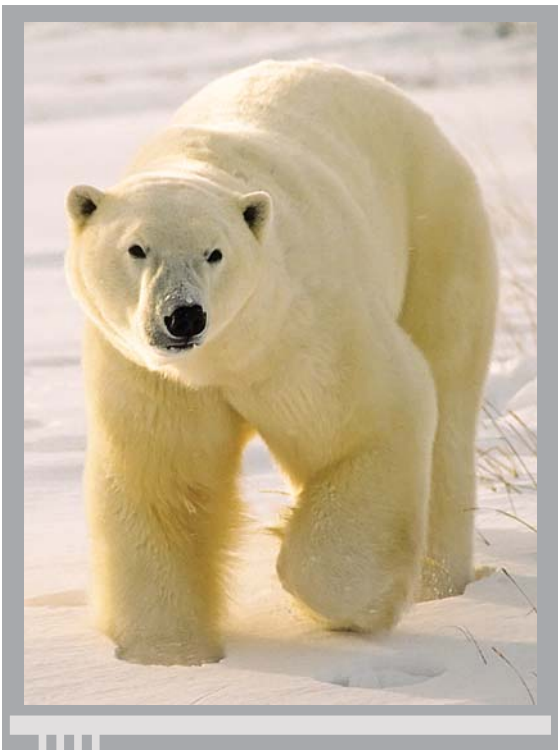

TFT 320x240 display with 262.144 colors

mikromedia for PIC24EP Schematics ver. 1.00

0 100000 020425

HW REV. 1.00

Copyright 2003-2012 by MikroElektronika. All rights reserved.

MikroElektronika assumes no responsibility or liability for any errors or inaccuracies that may appear in the present document. Specification and information contained in the present schematic are subject to change at any time without notice.

SCHEMATICS

mikromedia™

for PIC24EP®

We present you with a complete color schematics for mikromedia™ for PIC24EP® development board. We want you to know what your board is consisted of and how it actually works.

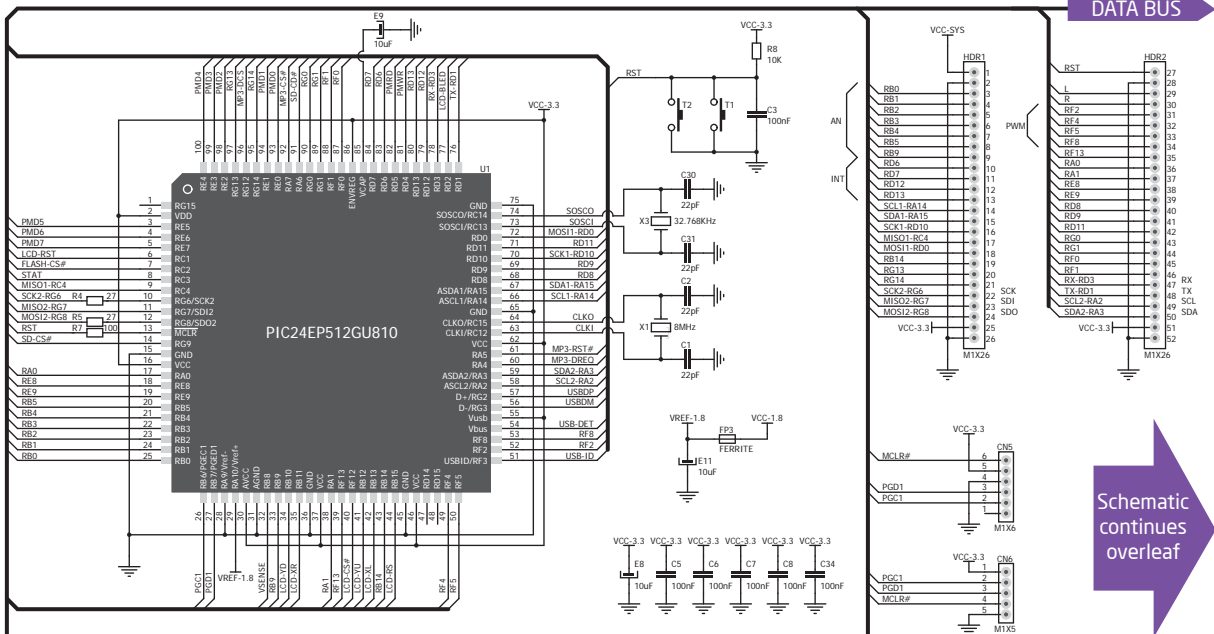

Schematic continues overleaf

