

EXTRUSION

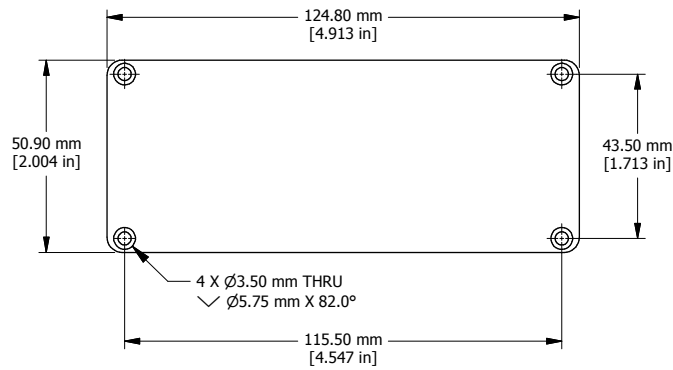

END PLATE

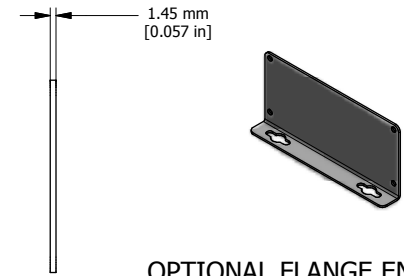

OPTIONAL FLANGE END PANEL
1455QF

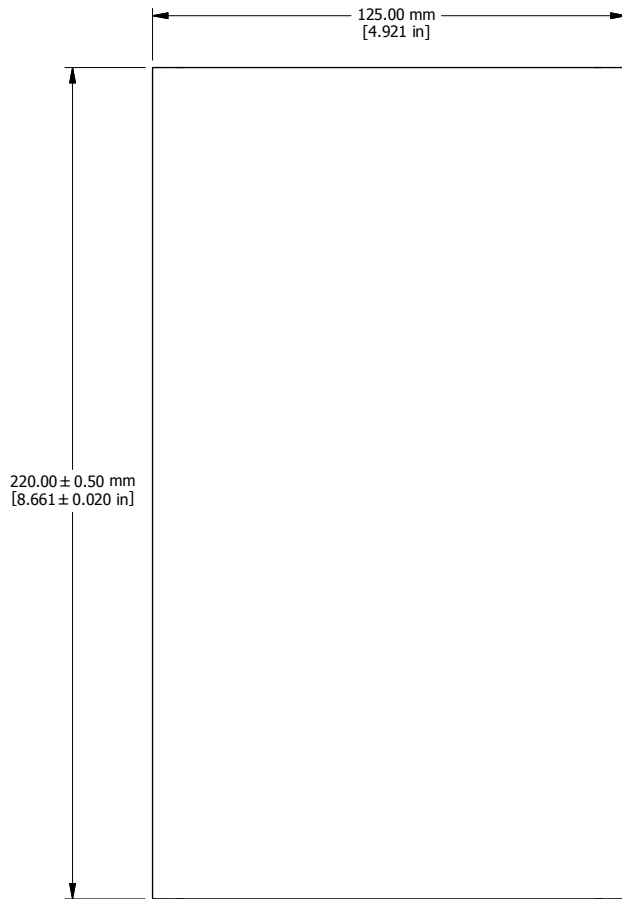

EXTRUSION DESIGNED FOR 120MM WIDE PC BOARD

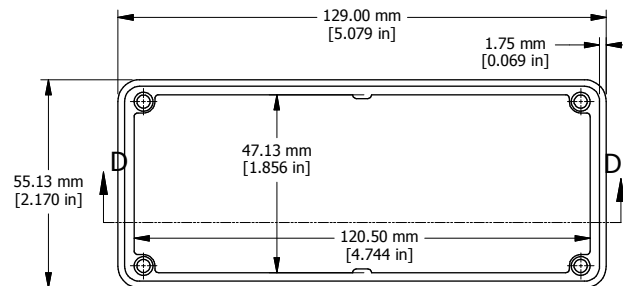

OPEN BEZEL

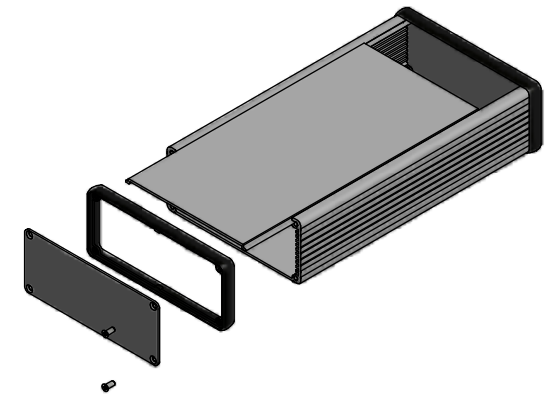
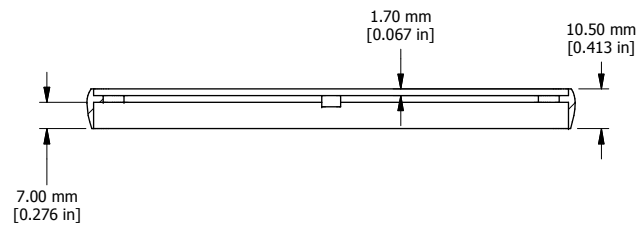

EXPLODED ASSEMBLY VIEW

Enclosures can be Factory Modified (Milling, Drilling, Printing etc.)
Solid models of this enclosure available in STEP or IGES.
Contact Factory mjm@hammondmfg.com

NOTE

Purchased assembly includes box, plastic bezels, end panels, #6
Taptight screws and self adhesive rubber feet.

Box made from Extruded Aluminum 6063.

Bezels made with polycarbonate.

1455Q2201

PART NUMBERS

Clear Anodized	1455Q2201
Black Anodized	1455Q2201BK
Blue Anodized	1455Q2201BU
Red Anodized	1455Q2201RD

ACCESSORIES

See website for accessories.

