

DISPLAY Elektronik GmbH

DATA SHEET

LCD MODULE

DEM 128064E1 FGH-PW

Product Specification

Version: 1

16.06.2023

GENERAL SPECIFICATION

MODULE NO. :

DEM 128064E1 FGH-PW

CUSTOMER P/N:

VERSION NO.	CHANGE DESCRIPTION	DATE
0	Original Version	13.06.2023
1	Show the diameter 2- \varnothing 1.5 of the plastic nose on page3/page4;Correct the BL IF=80mA on page 7.	16.06.2023

PREPARED BY: LM

DATE: 16.06.2023

APPROVED BY: WH

DATE: 16.06.2023

CONTENTS

1. FUNCTIONS & FEATURES.....2

2. MECHANICAL SPECIFICATIONS2

3. EXTERNAL DIMENSIONS3

4. BLOCK DIAGRAM4

5. PIN ASSIGNMENT5

6. BACKLIGHT ELECTRICAL/OPTICAL SPECIFICATIONS7

7. ABSOLUTE MAXIMUM RATINGS8

8. ELECTRICAL CHARACTERISTICS.....8

9. COMMAND TABLE12

10. LCD ARTWORT.....13

11. ACCEPT QUALITY LEVEL (AQL).....16

12. RELIABILITY TEST16

13. LCD MODULES HANDLING PRECAUTIONS17

14. OTHERS17

1. FUNCTIONS & FEATURES

- DEM 128064E1-Series LCD Type :

MODULE	LCD TYPE	REMARK
DEM 128064E1 FGH-PW	FSTN Transflective Positive Mode	-

- Viewing Direction : 6 O'clock
- Driving Scheme : 1/65 Duty, 1/9 Bias
- Power Supply Voltage : 3.0V
- V_{LCD} : 9.0V
- Display Contents : 128 x 64 Dots
- Driver IC : ST7565R
- RoHS : Compliant
- MPU Interface : 4-line SPI data input/8 bit data input

2. MECHANICAL SPECIFICATIONS

- Module Size : 77.40 x 52.40 x 10.50 mm
- Viewing Area : 70.00 x 40.00 mm
- Active Area : 66.54 x 33.26 mm
- Dot Size : 0.50 x 0.50 mm
- Dot Gap : 0.02 mm

3. EXTERNAL DIMENSIONS

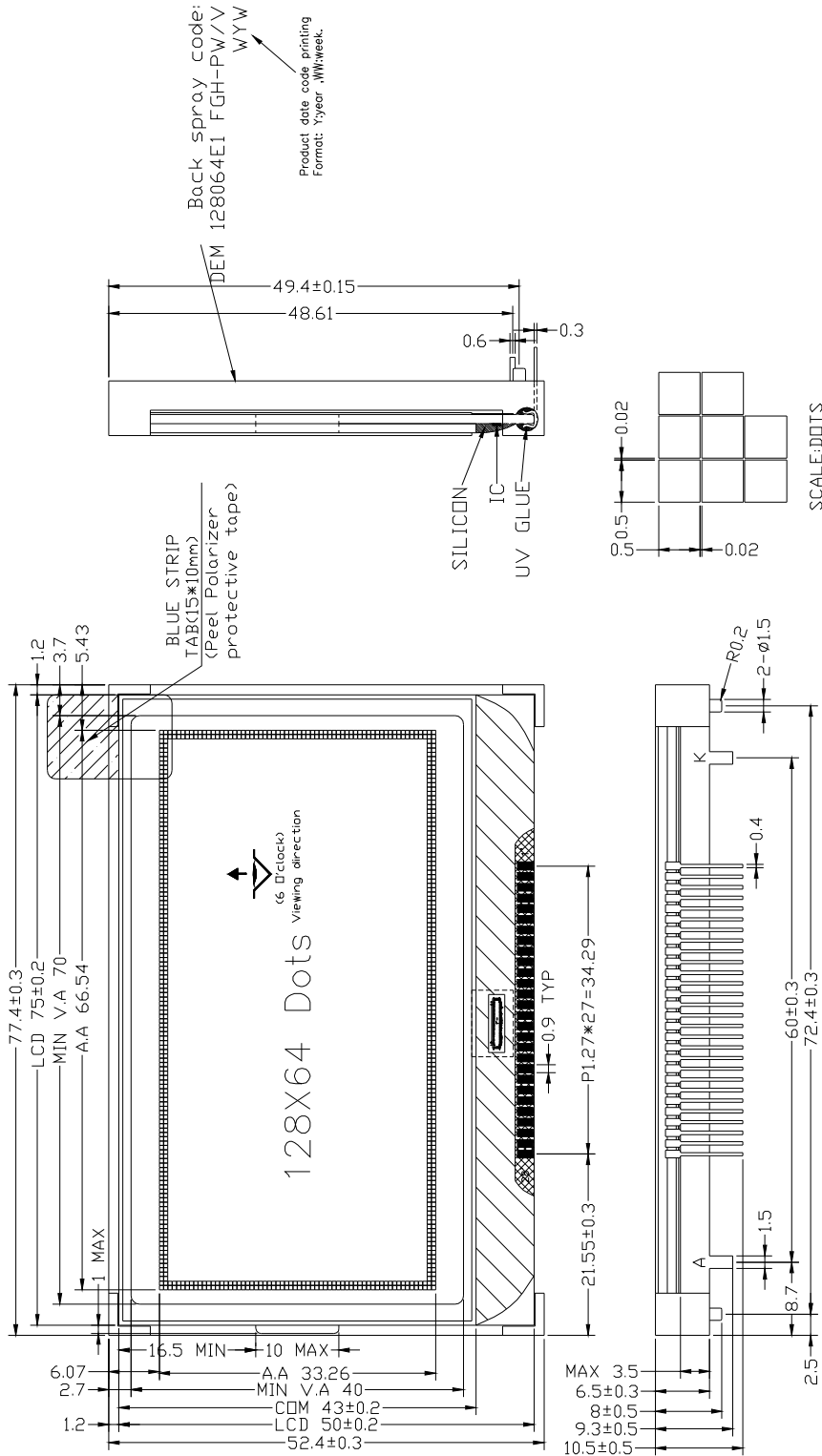

B00

- Remarks:
1. Unmarked tolerance is ±0.3
 2. All materials comply with RoHs
 3. ...critical dimension.

4. BLOCK DIAGRAM

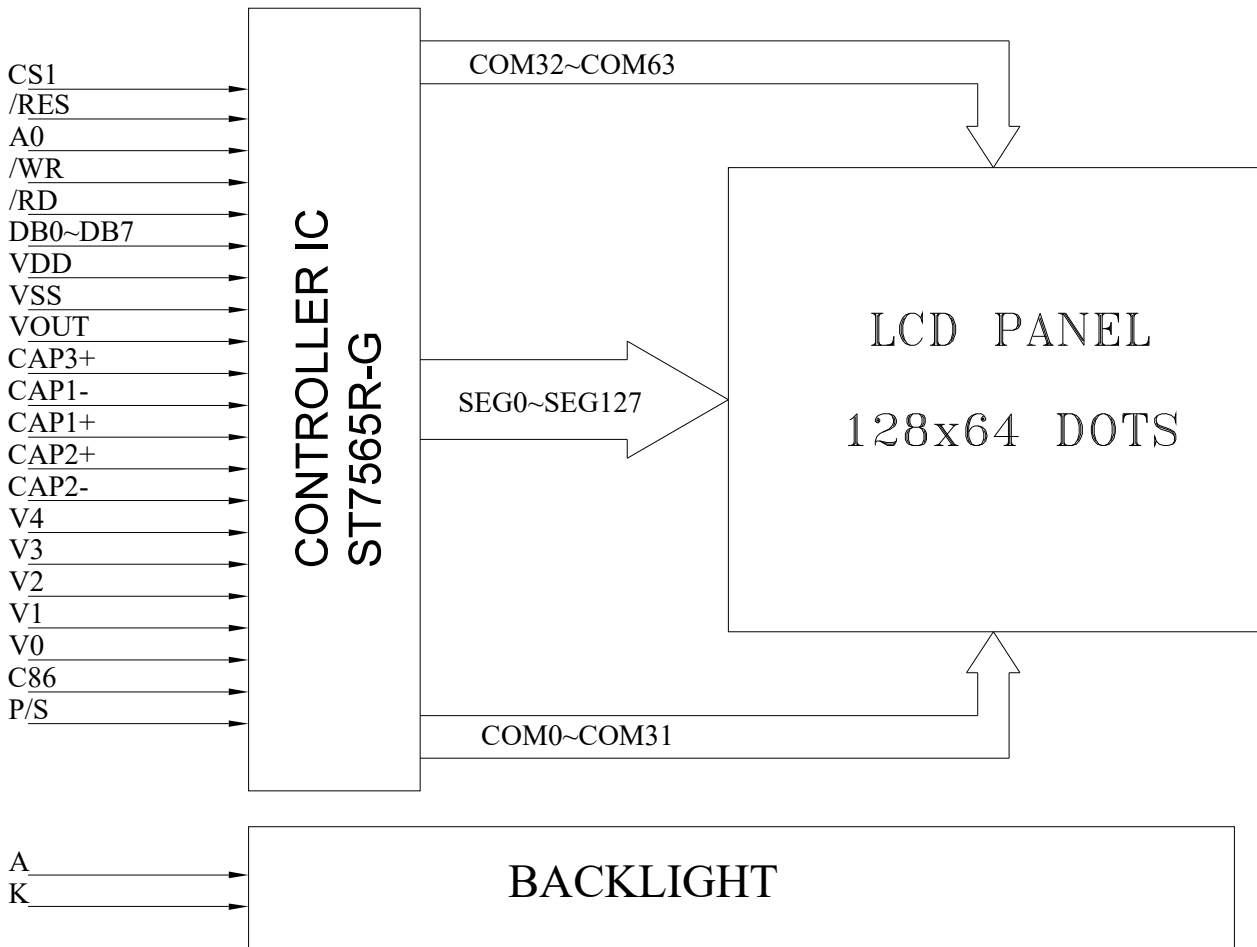

5. PIN ASSIGNMENT

5.1 PIN Assignment

PIN No.	Symbol	I/O	Description
1	CS1	I	the chip select signal.
2	/RES	I	When /RES is set to "L", the register settings are initialized (cleared). The reset operation is performed by the /RES signal level.
3	A0	I	This is connect to the least significant bit of the normal MPU address bus, and it determines whether the data bits are data or command. A0 = "H": Indicates that D0 to D7 are display data. A0 = "L": Indicates that D0 to D7 are control data.
4	/WR	I	When connected to 8080 series MPU, this pin is treated as the "/WR" signal of the 8080 MPU and is LOW-active. The signals on the data bus are latched at the rising edge of the /WR signal. When connected to 6800 series MPU, this pin is treated as the "RW" signal of the 6800 MPU and decides the access type : When R/W = "H": Read. When R/W = "L": Write.
5	/RD	I	When connected to 8080 series MPU, this pin is treated as the "/RD" signal of the 8080MPU and is LOW-active. The data bus is in an output status when this signal is "L". When connected to 6800 series MPU, this pin is treated as the "E" signal of the 6800.MPU and is HIGH-active.This is the enable clock input terminal of the 6800 Series MPU.
6~13	DB0~DB7	I/O	Data bus. This is an 8-bit bi-directional data bus that connects to an 8-bit or 16-bit standard MPU data bus. When the serial interface (SPI-4) is selected (P/S = "L") : D7: serial data input (SI); D6: the serial clock input (SCL). D0 to D5 should be connected to VDD or floating. When the chip select is not active, D0 to D7 are set to high impedance.
14	VDD	Power	Power Supply.
15	VSS	Power	Ground
16	VOUT	O	DC/DC voltage converter. Connect a capacitor between this terminal and VSS or VDD terminal.
17	CAP3+	O	DC/DC voltage converter. Connect a capacitor between this terminal and the CAP1N terminal.
18	CAP1-	O	DC/DC voltage converter. Connect a capacitor between this terminal and the CAP1P terminal.
19	CAP1+	O	DC/DC voltage converter. Connect a capacitor between this terminal and the CAP1N terminal.
20	CAP2+	O	DC/DC voltage converter. Connect a capacitor between this terminal and the CAP2N terminal.
21	CAP2-	O	DC/DC voltage converter. Connect a capacitor between this terminal and the CAP2P terminal.
22	V4	I/O	This is a multi-level power supply for the liquid crystal drive. The voltage Supply applied is determined by the liquid crystal cell, and is changed through the use of a resistive voltage divided or through changing the impedance using an op. amp. Voltage levels are determined based on Vss, and must maintain the relative magnitudes shown below. $V0 \cong V1 \cong V2 \cong V3 \cong V4 \cong Vss$
23	V3	I/O	
24	V2	I/O	
25	V1	I/O	

26	V0	I/O	<table border="1" data-bbox="539 255 798 427"> <tr> <td></td> <td>1/65 DUTY</td> </tr> <tr> <td>V1</td> <td>8/9*V0,6/7*V0</td> </tr> <tr> <td>V2</td> <td>7/9*V0,5/7*V0</td> </tr> <tr> <td>V3</td> <td>2/9*V0,2/7*V0 1</td> </tr> <tr> <td>V4</td> <td>9*V0,1 7*V0</td> </tr> </table>		1/65 DUTY	V1	8/9*V0,6/7*V0	V2	7/9*V0,5/7*V0	V3	2/9*V0,2/7*V0 1	V4	9*V0,1 7*V0					
	1/65 DUTY																	
V1	8/9*V0,6/7*V0																	
V2	7/9*V0,5/7*V0																	
V3	2/9*V0,2/7*V0 1																	
V4	9*V0,1 7*V0																	
27	C86	I	<p>This is the MPU interface selection pin. C86 = "H": 6800 Series MPU interface. C86 = "L": 8080 Series MPU interface. The following applies depending on the P/S status:</p> <table border="1" data-bbox="539 607 1431 703"> <thead> <tr> <th>P/S</th> <th>Data/Command</th> <th>Data</th> <th>Read/Write</th> <th>4-line SPI Clock</th> </tr> </thead> <tbody> <tr> <td>"H"</td> <td>A0</td> <td>D0 to D7</td> <td>/RD, /WR</td> <td>X</td> </tr> <tr> <td>"L"</td> <td>A0</td> <td>SI (D7)</td> <td>Write only</td> <td>SCL (D6)</td> </tr> </tbody> </table> <p>When P/S = "L", D0 to D5 must be fixed to "H". /RD (E) and /WR (R/W) are fixed to either "H" or "L". The serial access mode does NOT support read operation.</p>	P/S	Data/Command	Data	Read/Write	4-line SPI Clock	"H"	A0	D0 to D7	/RD, /WR	X	"L"	A0	SI (D7)	Write only	SCL (D6)
P/S	Data/Command	Data	Read/Write	4-line SPI Clock														
"H"	A0	D0 to D7	/RD, /WR	X														
"L"	A0	SI (D7)	Write only	SCL (D6)														
28	P/S	I	<p>This pin configures the interface to be parallel mode or serial mode. P/S = "H": Parallel data input/output. P/S = "L": Serial data input.</p>															

6. BACKLIGHT ELECTRICAL/OPTICAL SPECIFICATIONS

ELECTRICAL-OPTICAL-CHARACTERISTICS

Item	Symbol	min.	typ.	max.	Unit	Condition
Forward Voltage	Vf	2.8	3.0	3.3	V	If= 4*20 mA
Power Dissipation	Pd	-	-	264	mW	If= 80 mA
Luminous Uniformity	ΔLv	70			%	MIN/MAX*100%
Luminance	Lv		250		cd/m ²	If= 80 mA T=25°C
Color Coordinate	X	0.250		0.330		
	Y	0.250		0.330		
Peak wave length	λP	-	-	-	nm	

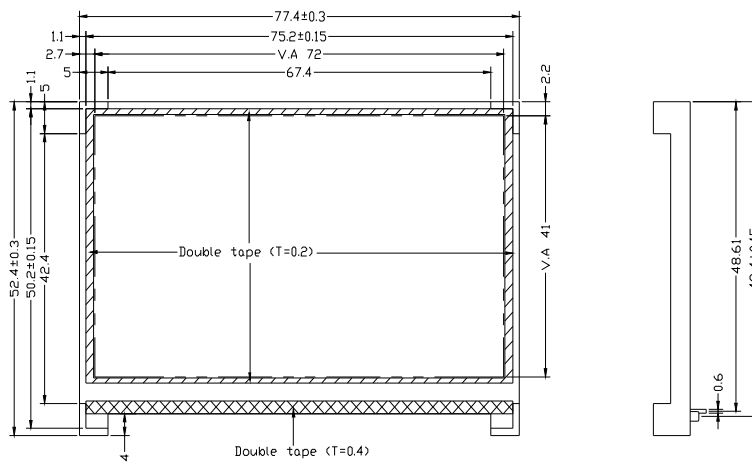

CIRCUIT DIAGRAM:

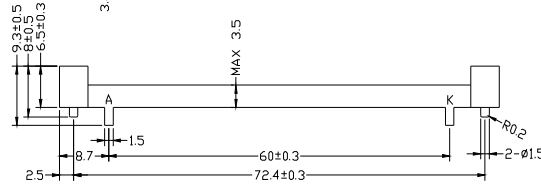
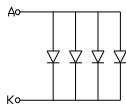

Remarks:

- 1.Unmarked tolerance is ±0.3
- 2.All materials comply with RoHs
3. ...critical dimension.
- 4.COLOR:WHITE ,NO. OF SMT LED:4PCS,
- 5.LED Lifetime:50000h.

7. ABSOLUTE MAXIMUM RATINGS

ITEM	SYMBOL	MIN.	TYP.	MAX.	UNIT
Power Supply for Logic	VDD-VSS	-0.3	---	3.6	V
Power Supply for LCD	V0-VSS	-0.3	---	13.5	V
Supply Voltage for LED Backlight	VLED	---	3.2	---	V
Operating Temperature	Top	-20	---	70	°C
Storage Temperature	Tst	-30	---	80	°C

8. ELECTRICAL CHARACTERISTICS

8-1. Electrical Characteristics (Ta=25°C, VDD=3.0V)

ITEM	SYMBOL	CONDITION	MIN.	TYP.	MAX.	UNIT
Power Supply for LCM	VDD-VSS	---	2.85	3.0	3.15	V
LCD Module Driving Voltage	V0-VSS	25°C		9.0		V
Input Voltage	VIL	L Level	Vss	---	0.2VDD	V
	VIH	H Level	0.8VDD	---	VDD	V
Supply Current for LCM	IDD	VDD=3.0V	---	0.5	---	mA
	Ie	---	---	---	---	
	ILED	VLED=3.2V	---	80	---	

8-2 AC characteristics

8-2-1 The 4-line SPI Interface

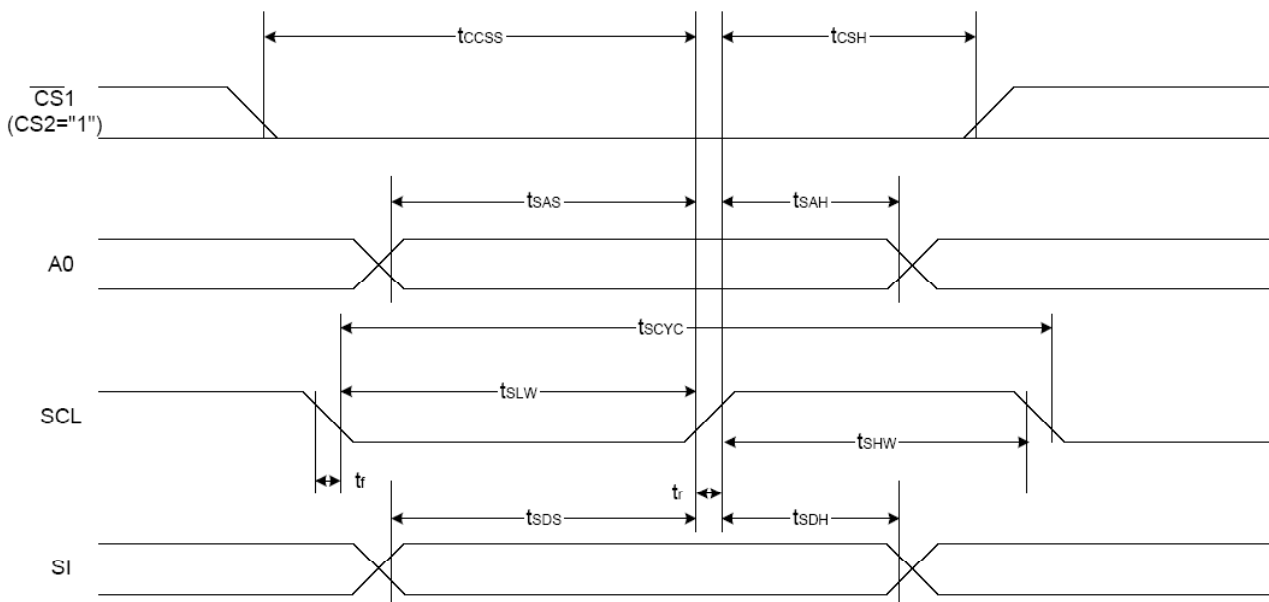

Item	Signal	Symbol	Condition	Rating		Units
				Min.	Max.	
4-line SPI Clock Period	SCL	T_{scyc}		50	—	ns
SCL "H" pulse width		T_{shw}		25	—	
SCL "L" pulse width		T_{slw}		25	—	
Address setup time	A0	T_{sas}		20	—	
Address hold time		T_{sah}		10	—	
Data setup time	SI	T_{sds}		20	—	
Data hold time		T_{sdh}		10	—	
CS-SCL time	CS	T_{css}		20	—	
CS-SCL time		T_{csh}		40	—	

8-2-2 The 8080 Series MPU

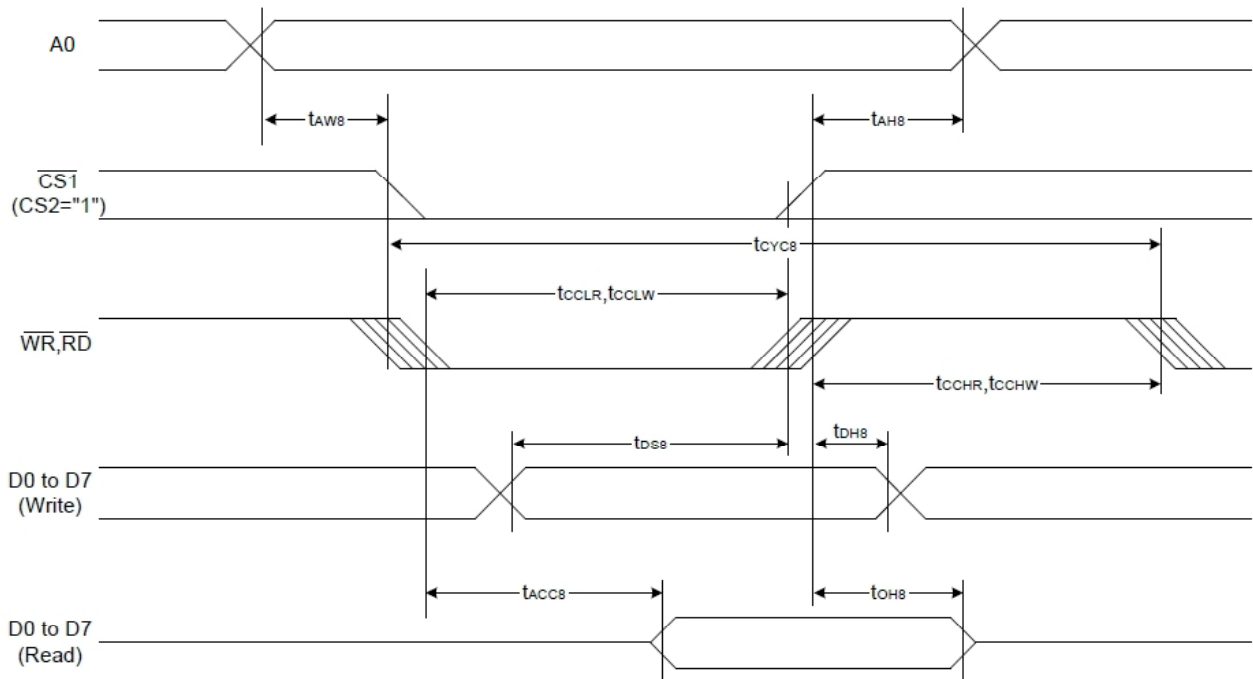

Item	Signal	Symbol	Condition	Rating		Units
				Min.	Max.	
Address hold time	A0	tAH8		0	—	Ns
Address setup time		tAW8		0	—	
System cycle time		tCYC8		240	—	
Enable L pulse width (WRITE)	WR	tCCLW		80	—	
Enable H pulse width (WRITE)		tCCHW		80	—	
Enable L pulse width (READ)	RD	tCCLR		140	—	
Enable H pulse width (READ)		tCCHR		80	—	
WRITE Data setup time	D0 to D7	tDS8		40	—	
WRITE Address hold time		tDH8		0	—	
READ access time		tACC8	CL = 100 pF	—	70	
READ Output disable time		tOH8	CL = 100 pF	5	50	

8-2-3 The 6800 Series MPU

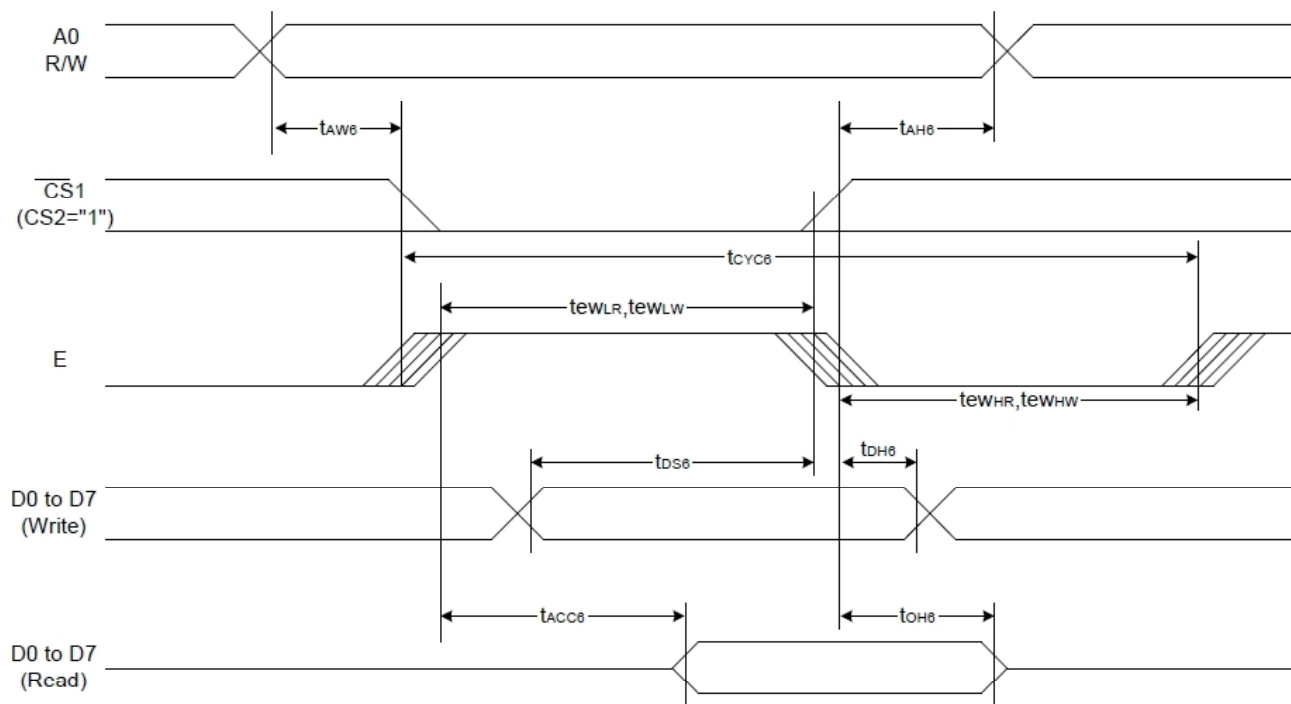

Item	Signal	Symbol	Condition	Rating		Units
				Min.	Max.	
Address hold time	A0	tAH6		0	—	ns
Address setup time		tAW6		0	—	
System cycle time		tCYC6		240	—	
Enable L pulse width (WRITE)	WR	tEWLW		80	—	
Enable H pulse width (WRITE)		tEWHW		80	—	
Enable L pulse width (READ)	RD	tEWLR		80	—	
Enable H pulse width (READ)		tEWHR		140	—	
WRITE Data setup time	D0 to D7	tDS6		40	—	
WRITE Address hold time		tDH6		0	—	
READ access time		tACC6	CL = 100 pF	—	70	
READ Output disable time		tOH6	CL = 100 pF	5	50	

8-3. Reset Characteristics

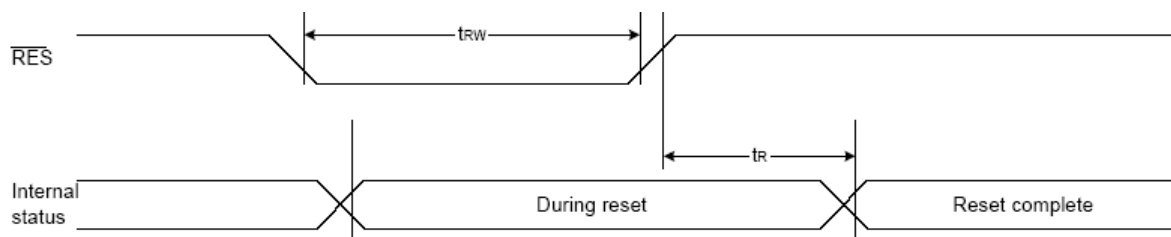

Item	Signal	Symbol	Condition	Rating			Units
				Min.	Typ.	Max.	
Reset Time		tR		—	—	1.0	us
Reset "L" Pulse Width	/RES	tRW		1.0	—	—	us

9. COMMAND TABLE

Command	Command Code										Function		
	A0	/RD	/WR	D7	D6	D5	D4	D3	D2	D1		D0	
(1) Display ON/OFF	0	1	0	1	0	1	0	1	1	1	0	1	LCD display ON/OFF 0: OFF, 1: ON
(2) Display start line set	0	1	0	0	1	Display start address						Sets the display RAM display start line address	
(3) Page address set	0	1	0	1	0	1	1	Page address				Sets the display RAM page address	
(4) Column address set upper bit Column address set lower bit	0	1	0	0	0	0	1	Most significant column address				Sets the most significant 4 bits of the display RAM column address.	
				0	0	0	0	Least significant column address				Sets the least significant 4 bits of the display RAM column address.	
(5) Status read	0	0	1	Status				0	0	0	0	Reads the status data	
(6) Display data write	1	1	0	Write data								Writes to the display RAM	
(7) Display data read	1	0	1	Read data								Reads from the display RAM	
(8) ADC select	0	1	0	1	0	1	0	0	0	0	0	1	Sets the display RAM address SEG output correspondence 0: normal, 1: reverse
(9) Display normal/reverse	0	1	0	1	0	1	0	0	1	1	0	1	Sets the LCD display normal/ reverse 0: normal, 1: reverse
(10) Display all points ON/OFF	0	1	0	1	0	1	0	0	1	0	0	1	Display all points 0: normal display 1: all points ON
(11) LCD bias set	0	1	0	1	0	1	0	0	0	1	0	1	Sets the LCD drive voltage bias ratio 0: 1/9 bias, 1: 1/7 bias (ST7565R)
(12) Read-modify-write	0	1	0	1	1	1	0	0	0	0	0	0	Column address increment At write: +1 At read: 0
(13) End	0	1	0	1	1	1	0	1	1	1	0	0	Clear read/modify/write
(14) Reset	0	1	0	1	1	1	0	0	0	1	0	0	Internal reset
(15) Common output mode select	0	1	0	1	1	0	0	0	*	*	*	*	Select COM output scan direction 0: normal direction 1: reverse direction
(16) Power control set	0	1	0	0	0	1	0	1	Operating mode			Select internal power supply operating mode	
(17) V ₀ voltage regulator internal resistor ratio set	0	1	0	0	0	1	0	0	Resistor ratio			Select internal resistor ratio(Rb/Ra) mode	
(18) Electronic volume mode set Electronic volume register set	0	1	0	1	0	0	0	0	0	0	0	1	Set the V ₀ output voltage electronic volume register
				0	0	Electronic volume value							
(19) Static indicator ON/OFF Static indicator register set	0	1	0	1	0	1	0	1	1	0	0	1	0: OFF, 1: ON Set the flashing mode
				0	0	0	0	0	0	0	0	Mode	
(20) Booster ratio set	0	1	0	1	1	1	1	1	0	0	0	0	select booster ratio 00: 2x,3x,4x 01: 5x 11: 6x
				0	0	0	0	0	0	0	0	step-up value	
(21) Power save	0	1	0									Display OFF and display all points ON compound command	
(22) NOP	0	1	0	1	1	1	0	0	0	1	1	1	Command for non-operation
(23) Test	0	1	0	1	1	1	1	*	*	*	*	*	Command for IC test. Do not use this command

10. LCD ARTWORK

10-1. LCD ARTWORK

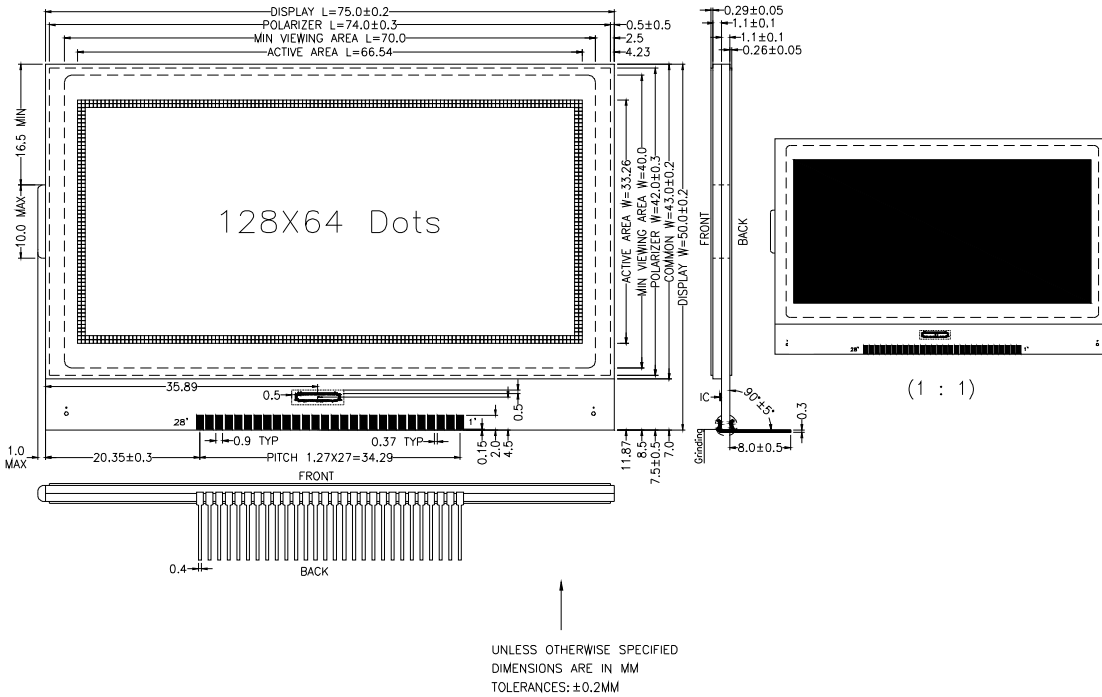

10-2. COMMON LAYOUT

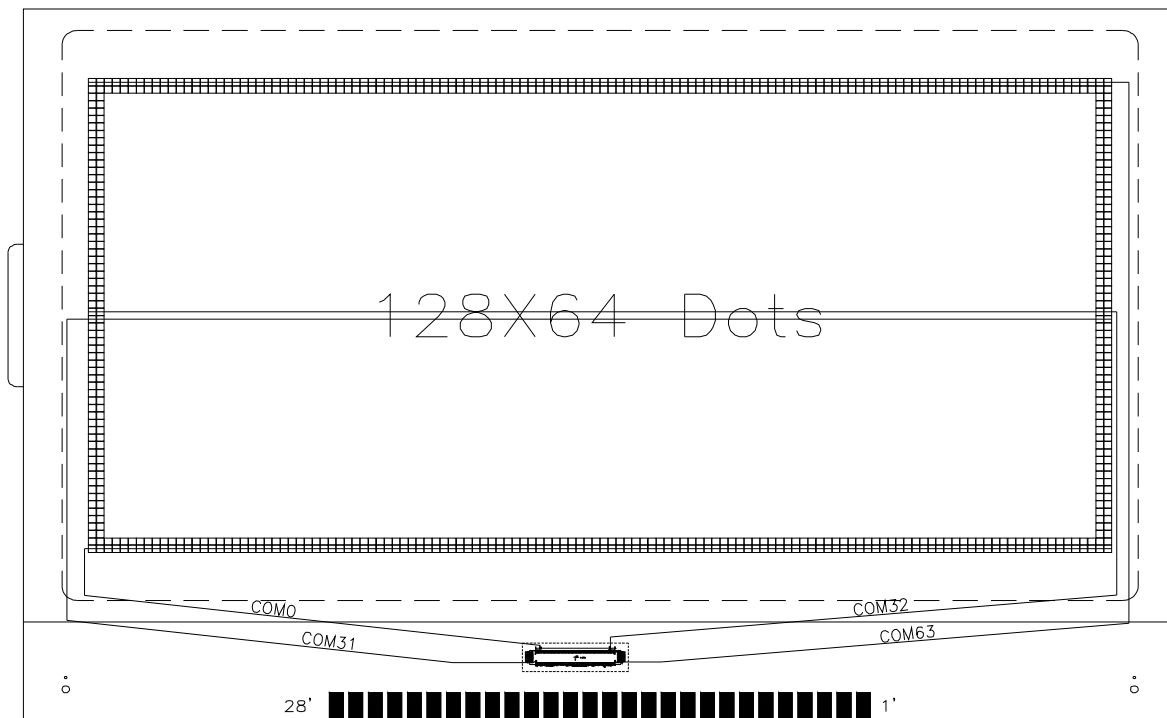

10-3. SEGMENT LAYOUT

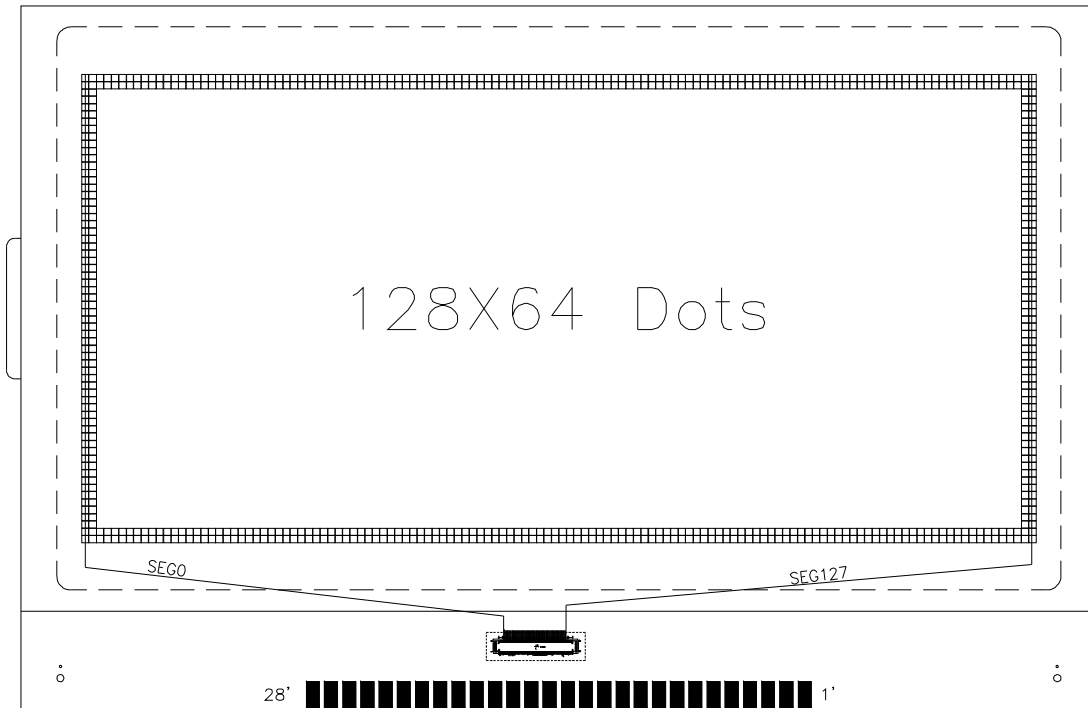

10-4. GRAPHIC DIMENSION & PAD CONFIGURATION

PAD NO.	PAD CONFIGURATION
1	COM63[R63(C0-C127)]
32	COM32[R32(C0-C127)]
33	SEG127[C127(R0-R63)]
160	SEG0[C0(R0-R63)]
161	COM0[R0(C0-C127)]
192	COM31[R31(C0-C127)]

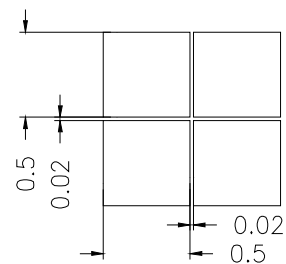

UNLESS OTHERWISE SPECIFIED
DIMENSIONS ARE IN MM
TOLERANCES: ±0.1MM

10-5. PAD CONFIGURATION IC NO CONFIGURATION

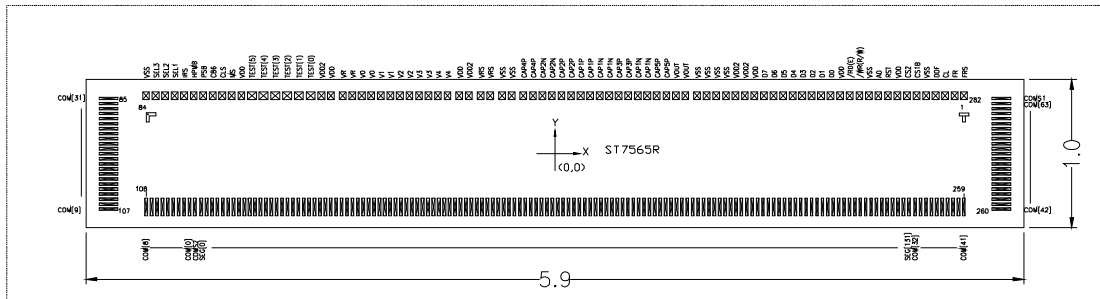

PAD_NO.	IC_NO.	CONFIGURATION	PAD_NO.	IC_NO.	CONFIGURATION
1'	CS1B		17'	CAP3P	
2'	RES(RST)		18'	CAP1N	
3'	A0		19'	CAP1P	
4'	/WR(R/W)		20'	CAP2P	
5'	/RD(E)		21'	CAP2N	
6'	D0		22'	V4	
7'	D1		23'	V3	
8'	D2		24'	V2	
9'	D3		25'	V1	
10'	D4		26'	V0	
11'	D5		27'	C86	
12'	D6		28'	P/S(PCB)	
13'	D7				
14'	VDD,VDD2				
15'	VSS,SEL1,SEL2,SEL3,HPMB				
16'	VOUT				

10-6. IC LAYOUT

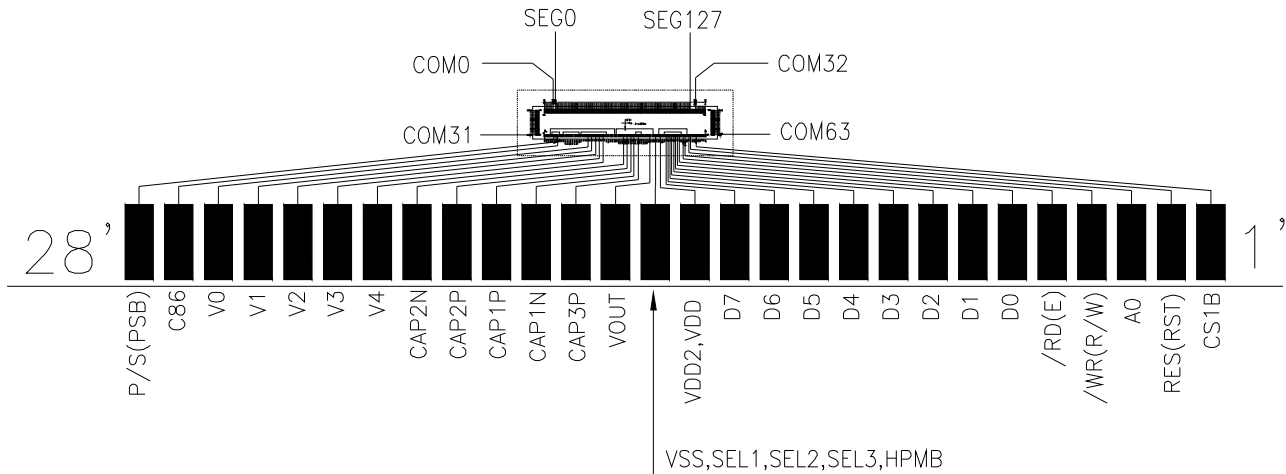

11. ACCEPT QUALITY LEVEL (AQL)

11.1 AQL Standard Value: Critical Defect =0.1, Major Defect=0.65; Minor Defect =2.5.

11.2 Inspection Plan: ANSI Z-1.4, Normal Inspection Level II, Single Sampling Plan

12. RELIABILITY TEST

Operating life time: 50000 hours (at room temperature without direct irradiation of sunlight)

Reliability characteristics shall meet following requirements.

Test Item	Test Condition
High Temperature Storage	+80°C x 96hrs
Low Temperature Storage	-30°C x 96hrs
High Temperature Operation	+70°C x 96hrs
Low Temperature Operation	-20°C x 96hrs
High Temperature, High Humidity	+60°C x 90%RH x 96hrs
Thermal Shock	-20°C x 30min → +25°C x 10s → +70°C x 30min 10 Cycles
Vibration 'Test	Frequency x Swing x Time 40Hz x 4mm x 4hrs
Drop Test	Drop height x No. of drops 1.0m x 6drops

13. LCD MODULES HANDLING PRECAUTIONS

- The display panel is made of glass. Do not subject it to a mechanical shock by dropping it from a high place, etc.
- If the display panel is damaged and the liquid crystal substance inside it leaks out, do not get any in your mouth. If the substance come into contact with your skin or clothes promptly wash it off using soap and water.
- Do not apply excessive force to the display surface or the adjoining areas since this may cause the color tone to vary.
- The polarizer covering the display surface of the LCD module is soft and easily scratched. Handle this polarize carefully.
- To prevent destruction of the elements by static electricity, be careful to maintain an optimum work environment.
 - Be sure to ground the body when handling the LCD module.
 - Tools required for assembly, such as soldering irons, must be properly grounded.
 - To reduce the amount of static electricity generated, do not conduct assembly and other work under dry conditions.
 - The LCD module is coated with a film to protect the display surface. Exercise care when peeling off this protective film since static electricity may be generated.
- Storage precautions
When storing the LCD modules, avoid exposure to direct sunlight or to the light of fluorescent lamps. Keep the modules in bags designed to prevent static electricity charging under low temperature / normal humidity conditions (avoid high temperature / high humidity and low temperatures below 0°C). Whenever possible, the LCD modules should be stored in the same conditions in which they were shipped from our company.

14. OTHERS

- Liquid crystals solidify at low temperature (below the storage temperature range) leading to defective orientation of liquid crystal or the generation of air bubbles (black or white). Air bubbles may also be generated if the module is subjected to a strong shock at a low temperature.
- If the LCD modules have been operating for a long time showing the same display patterns may remain on the screen as ghost images and a slight contrast irregularity may also appear. Abnormal operating status can be resumed to be normal condition by suspending use for some time. It should be noted that this phenomena does not adversely affect performance reliability.
- To minimize the performance degradation of the LCD modules resulting from caused by static electricity, etc. exercise care to avoid holding the following sections when handling the modules:
 - Exposed area of the printed circuit board
 - Terminal electrode sections