

POWER RELAY

1 POLE—10A

VS SERIES

RoHS compliant

■ FEATURES

- UL, CSA, VDE, SEV, SEMKO, CQC recognized
- TV-5 is available
- Working class: C
- UL class B (130°C) insulation
- Type of service: continuous duty
- Heavy duty miniature slim type power relay
- High isolation in small package
 - Insulation distance: 8 mm
 - Dielectric strength: 5,000 VAC (between coil and contacts)
 - Surge strength: 10,000 V
- Standard and high sensitivity types available
- Flux free type and plastic sealed type available
- Lead Free since date code: 0437L2
Please see page 11 for more information
- Cadmium free is available



■ ORDERING INFORMATION

[Example] $\frac{VS}{(a)}$ - $\frac{12}{(*)}$ $\frac{S}{(b)}$ $\frac{M}{(c)}$ $\frac{B}{(d)}$ $\frac{U}{(e)}$ - $\frac{N}{(g)}$ - $\frac{UC}{(h)}$

(a)	Series Name	VS: VS Series
(b)	Nominal Voltage	Refer to the COIL DATA CHART
(c)	Coil Type	Nil : Standard type (700-750 mW) S : High sensitivity type (530 mW)
(d)	Contact Arrangement	T : 1 form C (SPDT) (non VS-NR type) M : 1 form A (SPST-NO)
(e)	Enclosure	B : Flux free type C : Plastic sealed type (with tape) K : Plastic sealed type
(f)	Standard	Nil : TV rating type U : Non TV rating type (standard type)
(g)	Contact Material	N : Silver alloy (10A) Nil : Silver-cadmium oxide (TV-5 rating type) 5 : Silver-cadmium oxide (non TV rating) Nil : Gold overlay silver-nickel (non TV rating) E : Silver-nickel (non TV rating)
(h)	Safety Standard	UC : UL, CSS SM2 : UL, CSA, VDE, SEMKO IM2 : UL, CSA, VDE, SEV, SEMKO

Note: Actual marking omits the hyphen (-) of (*)

VS SERIES

■ PART NUMBERS

Standard 700 to 750 mW

Ordering Part Number	Series	Coil	Coil Power	Contact		TV rating	Contact Material	Safety Standard
VS-3M(B, C, K)-(Nil,N)	VS	3	720	M: 1 form A	B: Flux free C: Plastic sealed with tape K: Plastic sealed	TV-5	N: Silver alloy Nil: Silver cadmium oxide	UC: UL,CSA SM2: UL, CSA, VDE, SEMKO
VS-5M(B, C, K)-(Nil,N)		5	700					
VS-6M(B, C, K)-(Nil,N)		6	720					
VS-9M(B, C, K)-(Nil,N)		9	700					
VS-12M(B, C, K)-(Nil,N)		12	720					
VS-14M(B, C, K)-(Nil,N)		14	700					
VS-18M(B, C, K)-(Nil,N)		18	700					
VS-24M(B, C, K)-(Nil,N)		24	700					
VS-36M(B, C, K)-(Nil,N)		36	700					
VS-48M(B, C, K)-(Nil,N)		48	700					
VS-60M(B, C, K)-(Nil,N)		60	700					
VS-100M(B, C, K)-(Nil,N)		100	750					

Ordering Part Number	Series	Coil	Coil Power	Contact		TV rating	Contact Material	Safety Standard
VS-3(M,T)(B,C,K)U-(Nil,5,E,N)	VS	3	720	M: 1 form A T: 1 form C	B: Flux free C: Plastic sealed with tape K: Plastic sealed	No TV-5	5: Silver cadmium oxide N: Silver alloy Nil: gold overlay-silver nickel E: Silver nickel	UC: UL,CSA IM2: UL, CSA, VDE, SEV, SEMKO
VS-5(M,T)(B,C,K)U-(Nil,5,E,N)		5	700					
VS-6(M,T)(B,C,K)U-(Nil,5,E,N)		6	720					
VS-9(M,T)(B,C,K)U-(Nil,5,E,N)		9	700					
VS-12(M,T)(B,C,K)U-(Nil,5,E,N)		12	720					
VS-14(M,T)(B,C,K)U-(Nil,5,E,N)		14	700					
VS-18(M,T)(B,C,K)U-(Nil,5,E,N)		18	700					
VS-24(M,T)(B,C,K)U-(Nil,5,E,N)		24	700					
VS-36(M,T)(B,C,K)U-(Nil,5,E,N)		36	700					
VS-48(M,T)(B,C,K)U-(Nil,5,E,N)		48	700					
VS-60(M,T)(B,C,K)U-(Nil,5,E,N)		60	700					
VS-100(M,T)(B,C,K)U-(Nil,5,E,N)		100	750					

VS SERIES

■ PART NUMBERS

High Sensitive type 530 mW

Ordering Part Number	Series	Coil	Coil Power	Contact		TV rating	Contact Material	Safety Standard
VS-3SM(B, C, K)-(Nil,N)	VS	3	530	M: 1 form A	B: Flux free C: Plastic sealed with tape K: Plastic sealed	TV-5	N: Silver alloy Nil: Silver cadmium oxide	UC: UL,CSA SM2: UL, CSA, VDE, SEMKO
VS-5SM(B, C, K)-(Nil,N)		5						
VS-6SM(B, C, K)-(Nil,N)		6						
VS-9SM(B, C, K)-(Nil,N)		9						
VS-12SM(B, C, K)-(Nil,N)		12						
VS-14SM(B, C, K)-(Nil,N)		14						
VS-18SM(B, C, K)-(Nil,N)		18						
VS-24SM(B, C, K)-(Nil,N)		24						
VS-36SM(B, C, K)-(Nil,N)		36						
VS-48SM(B, C, K)-(Nil,N)		48						
VS-60SM(B, C, K)-(Nil,N)		60						
VS-100SM(B, C, K)-(Nil,N)		100						

Ordering Part Number	Series	Coil	Coil Power	Contact		TV rating	Contact Material	Safety Standard
VS-3S(M,T)(B,C,K)U-(Nil,5,E,N)	VS	3	530	M: 1 form A T: 1 form C	B: Flux free C: Plastic sealed with tape K: Plastic sealed	No TV-5	5: Silver cadmium oxide N: Silver alloy Nil: gold overlay-silver nickel E: Silver nickel	UC: UL,CSA SM2: UL, CSA, VDE, SEMKO
VS-5S(M,T)(B,C,K)U-(Nil,5,E,N)		5						
VS-6S(M,T)(B,C,K)U-(Nil,5,E,N)		6						
VS-9S(M,T)(B,C,K)U-(Nil,5,E,N)		9						
VS-12S(M,T)(B,C,K)U-(Nil,5,E,N)		12						
VS-14S(M,T)(B,C,K)U-(Nil,5,E,N)		14						
VS-18S(M,T)(B,C,K)U-(Nil,5,E,N)		18						
VS-24S(M,T)(B,C,K)U-(Nil,5,E,N)		24						
VS-36S(M,T)(B,C,K)U-(Nil,5,E,N)		36						
VS-48S(M,T)(B,C,K)U-(Nil,5,E,N)		48						
VS-60S(M,T)(B,C,K)U-(Nil,5,E,N)		60						
VS-100S(M,T)(B,C,K)U-(Nil,5,E,N)		100						

■ COIL DATA CHART

Standard

Coil Voltage	Nominal Voltage	Max. Coil Voltage* ¹	Coil Resistance (±10%)	Must Operate Voltage* ²	Must Release Voltage* ²	Coil Power
3	3 VDC	4.95 VDC	12.5 Ω	2.1 VDC	0.3 VDC	720 mW
5	5 VDC	8.25 VDC	36 Ω	3.5 VDC	0.5 VDC	700 mW
6	6 VDC	9.90 VDC	50 Ω	4.2 VDC	0.6 VDC	720 mW
9	9 VDC	14.85 VDC	115 Ω	6.3 VDC	0.9 VDC	700 mW
12	12 VDC	19.8 VDC	200 Ω	8.4 VDC	1.2 VDC	720 mW
14	14 VDC	23.1 VDC	280 Ω	9.8 VDC	1.4 VDC	700 mW
18	18 VDC	29.7 VDC	460 Ω	12.6 VDC	1.8 VDC	700 mW
24	24 VDC	39.6 VDC	820 Ω	16.8 VDC	2.4 VDC	700 mW
36	36 VDC	59.4 VDC	1,850 Ω	25.2 VDC	3.6 VDC	700 mW
48	48 VDC	79.2 VDC	3,300 Ω	33.6 VDC	4.8 VDC	700 mW
60	60 VDC	99.0 VDC	5,100 Ω	42.0 VDC	6.0 VDC	700 mW
100	100 VDC	165 VDC	13,400 Ω	70.0 VDC	10.0 VDC	750 mW

High Sensitive

Coil Voltage	Nominal Voltage	Max. Coil Voltage* ¹	Coil Resistance (±10%)	Must Operate Voltage* ²	Must Release Voltage* ²	Coil Power
3	3 VDC	4.95 VDC	17 Ω	2.1 VDC	0.3 VDC	530 mW
5	5 VDC	8.25 VDC	47 Ω	3.5 VDC	0.5 VDC	530 mW
6	6 VDC	9.90 VDC	68 Ω	4.2 VDC	0.6 VDC	530 mW
9	9 VDC	14.85 VDC	115 Ω	6.3 VDC	0.9 VDC	530 mW
12	12 VDC	19.8 VDC	270 Ω	8.4 VDC	1.2 VDC	530 mW
14	14 VDC	23.1 VDC	370 Ω	9.8 VDC	1.4 VDC	530 mW
18	18 VDC	29.7 VDC	610 Ω	12.6 VDC	1.8 VDC	530 mW
24	24 VDC	39.6 VDC	1,000 Ω	16.8 VDC	2.4 VDC	530 mW
36	36 VDC	59.4 VDC	2,450 Ω	25.2 VDC	3.6 VDC	530 mW
48	48 VDC	79.2 VDC	4,400 Ω	33.6 VDC	4.8 VDC	530 mW
60	60 VDC	99.0 VDC	6,800 Ω	42.0 VDC	6.0 VDC	530 mW
100	100 VDC	165 VDC	18,860 Ω	70.0 VDC	10.0 VDC	530 mW

Note: All values in the table are measured at 20°C.

*1: No contact current at 20°C

*2: Specified values are subject to pulse wave voltage

■ SPECIFICATIONS

Item		TV-5 Rating Type		Standard		
		VS-()M	VS-()M-N	VS-()U-5	VS-()U-N	VS-()U VS-()U-E*
Contact	Arrangement	1 form A (SPST-NO), 1 form C, D (SPST-NO)				
	Material	Silver cadmium-oxide	Silver alloy	Silver cadmium-oxide	Silver alloy	Gold overlay silver nickel
	Style	Single				
	Resistance (initial) (at 1A 6VDC)	Max. 100mΩ				
	Rating (resistive)	10A 240VAC / 24VDC				
	Max. Carrying Current*1	14A				
	Max. Switching Power	2400VA / 240W				
	Max. Switching Voltage	250 VAC / 150VDC				
	Min. Switching Load*2	100mA 5VDC (M, 5, E), 10mA 5VDC (VS-)				
	Max. Inrush Current (at lamp load)	78A 120VAC	-			
Coil	Nominal Power (at 20°C)	Standard type: 700 to 750mW. High sensitive type: 530mW				
	Operate Power (at 20°C)	Standard type: 350 to 370mW. High sensitive type: 350mW				
	Operating Temperature	Standard type: -40°C to +85°C. High sensitive type: -40°C to +75°C (no frost)				
Time Value	Operate (at nominal value)	Maximum 15ms				
	Release (at nominal value)	Maximum 10ms				
Life	Mechanical	2x10 ⁷ operations minimum				
	Electrical	Contact rating	1x10 ⁵ operations minimum (resistive)			
		Motor	3x10 ⁴ operations minimum (at 1/4 HP 120VAC motor)			
		Lamp	5x10 ⁴ operations minimum (at 78A 120VAC, lamp) 1.5x10 ⁴ operations minimum (high sensitive type)	-		
Other	Vibration Resistance	Misoperation	10 to 55 Hz (double amplitude of 1.5mm)			
		Endurance	10 to 55 Hz (double amplitude of 1.5mm)			
	Shock Resistance	Misoperation	100m/s ² (11±1m/s)			
		Endurance	1,000m/s ² (6±1m/s)			
	Weight	Approximately 17g				

*1 When max. carrying current is more than 10A, PCB layout needs to be considered.

*2 Minimum switching loads mentioned above are reference values. Please perform the confirmation test with the actual load before production since reference values may vary according to switching frequencies, environmental conditions and expected reliability levels.

■ SAFETY STANDARDS

Type	Compliance	Contact rating
UL	UL 508 E56140	Flammability: UL 94-V0 (plastics) [TV-rating VS-()M, SM, M-N] 10A, 240VAC/24VDC (resistive) 1/3 hp, 240VAC/120VAC Pilot duty: C150 TV-5 120 VAC
1	C22.2 No. 14 LR 35579	[UN, SU-N] 15A, 120VAC/24VDC (resistive) 10A, 240VAC (resistive) 1/3 hp, 240VAC/120VAC Pilot duty: B150 [VS-() () U-(), ()S() U-()] 10A, 240VAC/24VDC (resistive) 1/3 hp, 240VAC/120VAC Pilot duty: C150
VDE	0435, 0631, 0700, 0860	

Complies with SEV, SEMKO, NEMKO, DEMKO, FIMKO, CQC, VDE,

■ INSULATION

Item	VS	Note
Resistance (initial)	Minimum 1,000 MΩ 1 min.	at 500 VDC
Dielectric Strength	open contacts	1,000 VAC (50/60 Hz) 1 min. 10mA detection current
	coil and contacts	5,000 VAC (50/60 Hz) 1 min. 10mA detection current
Surge Voltage (coil and contact)	10,000 V	1.2 x 50µs standard wave
Clearance/Creepage	8 mm / 8 mm	
Insulation (DIN EN61810-1 VDE0435)		
Voltage	250 V	
Pollution	2	
Isolation material group	III	

CHARACTERISTIC DATA

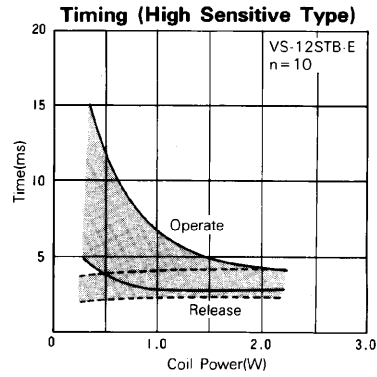
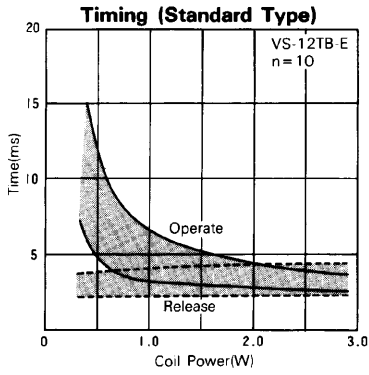

Coil Temperature Rise (Standard Type)

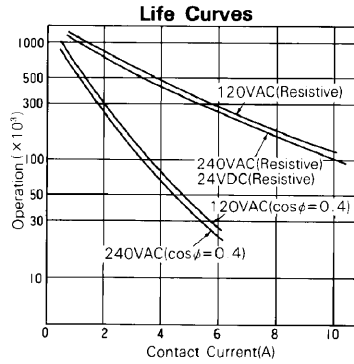
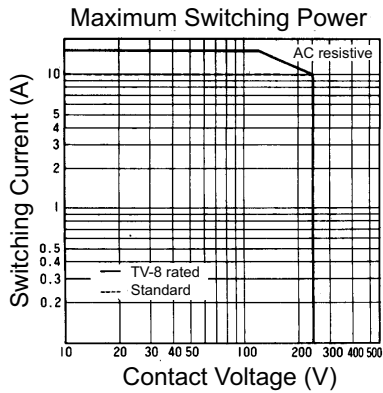
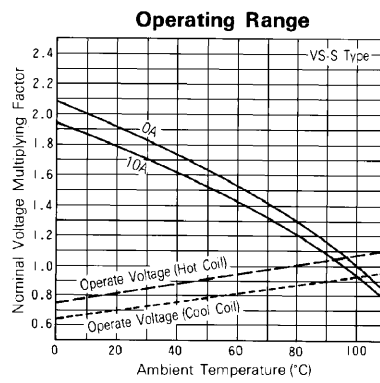
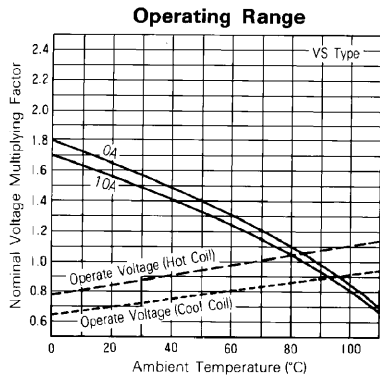
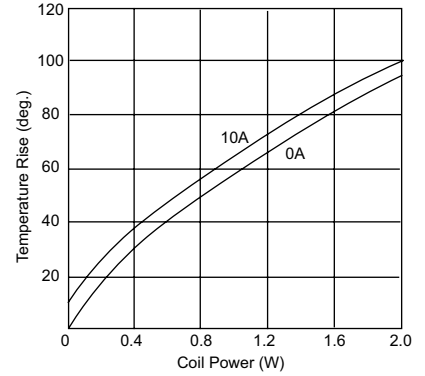

■ REFERENCE DATA

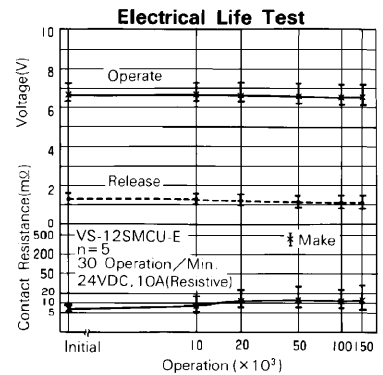
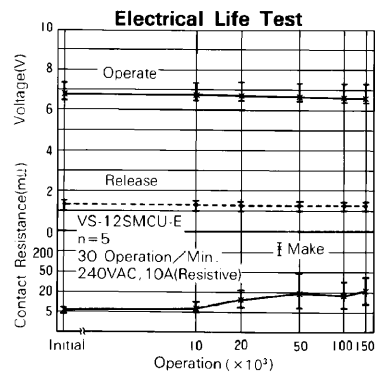
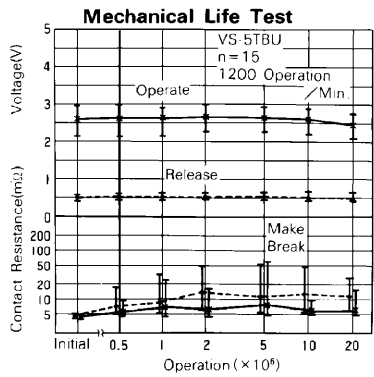
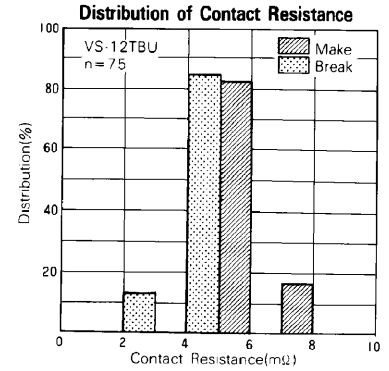
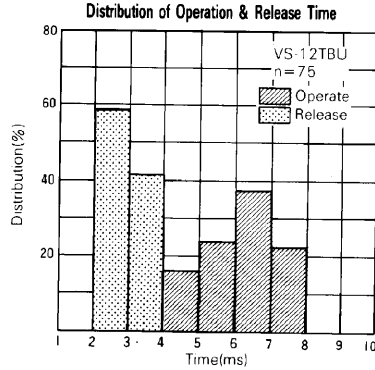
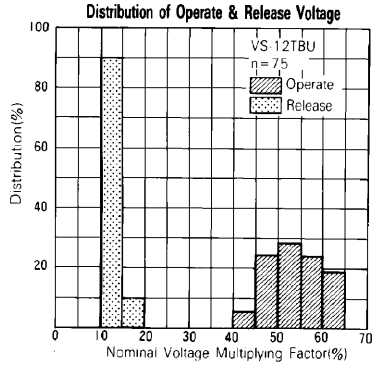

VS SERIES

■ DIMENSIONS

● Dimensions

VS-M type

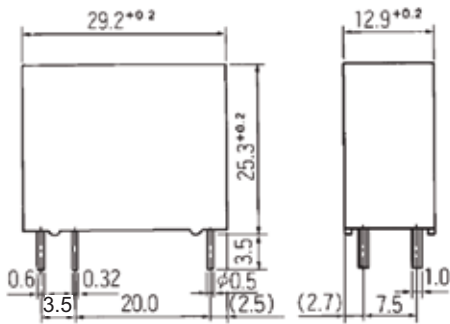

● Schematics (BOTTOM VIEW)

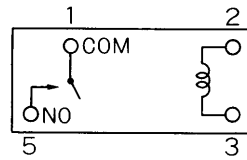

● PC board mounting hole layout (BOTTOM VIEW)

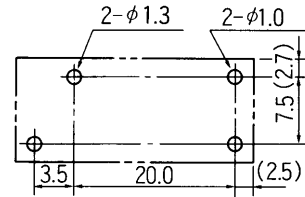

VS type

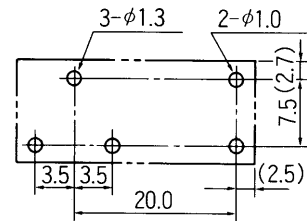
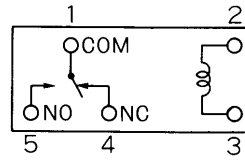
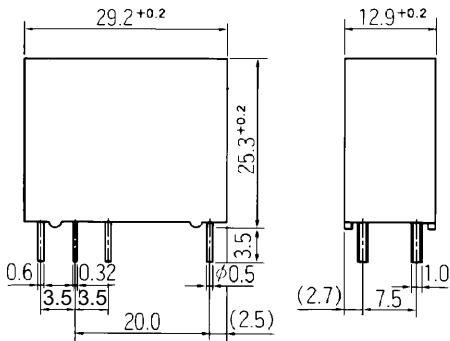

VS-MK type (Plastic sealed type)

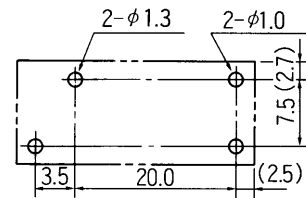
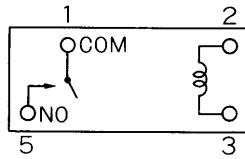
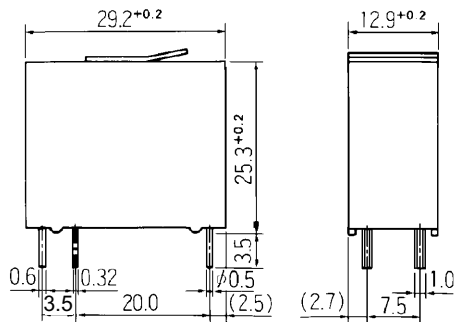

Unit: mm

VS SERIES

VS-K type (Plastic sealed type)

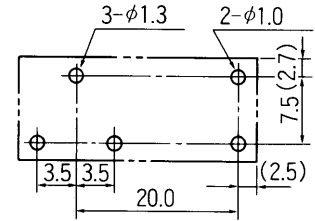
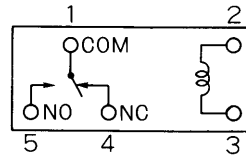
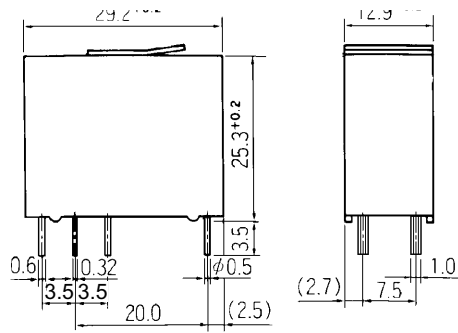

VS-MC type (Plastic sealed type with tape)

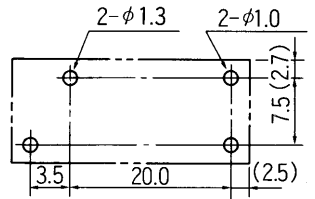
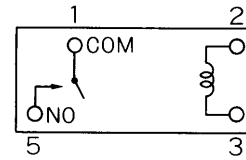
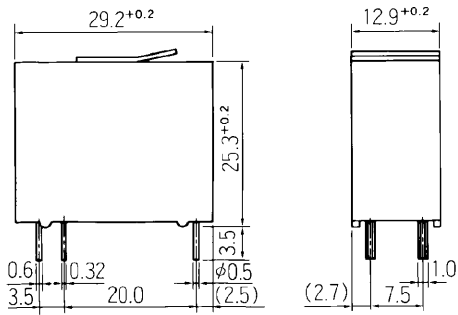

VS-C type (Plastic sealed type with tape)

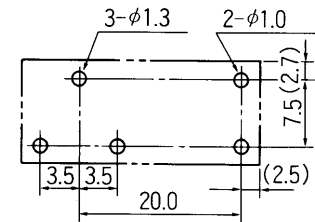
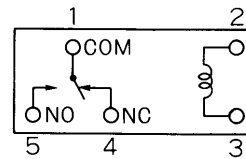
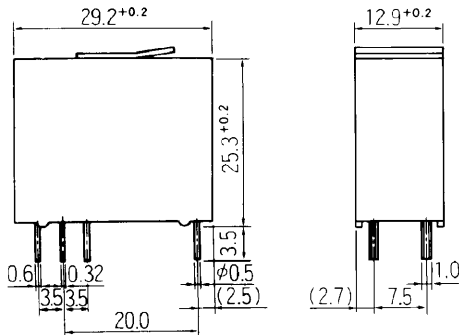

Unit: mm

RoHS Compliance and Lead Free Relay Information

1. General Information

- Relays produced after the specific date code that is indicated on each data sheet are lead-free now. All of our signal and power relays are lead-free. Please refer to Lead-Free Status Info. (<http://www.fujitsu.com/us/downloads/MICRO/fcai/relays/lead-free-letter.pdf>)
 - Lead free solder paste currently used in relays is Sn-3.0Ag-0.5Cu.
 - All signal and most power relays also comply with RoHS. Please refer to individual data sheets. Relays that are RoHS compliant do not contain the 5 hazardous materials that are restricted by RoHS directive (lead, mercury, chromium IV, PBB, PBDE).
 - It has been verified that using lead-free relays in leaded assembly process will not cause any problems (compatible).
 - "LF" is marked on each outer and inner carton. (No marking on individual relays).
 - To avoid leaded relays (for lead-free sample, etc.) please consult with area sales office.
 - We will ship leaded relays as long as the leaded relay inventory exists.
- Note: Cadmium was exempted from RoHS on October 21, 2005. (Amendment to Directive 2002/95/EC)

2. Recommended Lead Free Solder Profile

- Recommended solder paste Sn-3.0Ag-0.5Cu.

Reflow Solder condition

Flow Solder condition:

Pre-heating: maximum 120°C
Soldering: dip within 5 sec. at
260°C solder bath

Solder by Soldering Iron:

Soldering Iron
Temperature: maximum 360°C
Duration: maximum 3 sec.

We highly recommend that you confirm your actual solder conditions

3. Moisture Sensitivity

- Moisture Sensitivity Level standard is not applicable to electromechanical relays.

4. Tin Whisker

- Dipped SnAgCu solder is known as low risk tin whisker. No considerable length whisker was found by our in house test.

Fujitsu Components International Headquarter Offices

Japan

Fujitsu Component Limited
Gotanda-Chuo Building
3-5, Higashigotanda 2-chome, Shinagawa-ku
Tokyo 141, Japan
Tel: (81-3) 5449-7010
Fax: (81-3) 5449-2626
Email: promothq@ft.ed.fujitsu.com
Web: www.fcl.fujitsu.com

North and South America

Fujitsu Components America, Inc.
250 E. Caribbean Drive
Sunnyvale, CA 94089 U.S.A.
Tel: (1-408) 745-4900
Fax: (1-408) 745-4970
Email: components@us.fujitsu.com
Web: <http://www.fujitsu.com/us/services/edevices/components/>

Europe

Fujitsu Components Europe B.V.
Diamantlaan 25
2132 WV Hoofddorp
Netherlands
Tel: (31-23) 5560910
Fax: (31-23) 5560950
Email: info@fceu.fujitsu.com
Web: emea.fujitsu.com/components/

Asia Pacific

Fujitsu Components Asia Ltd.
102E Pasir Panjang Road
#01-01 Citilink Warehouse Complex
Singapore 118529
Tel: (65) 6375-8560
Fax: (65) 6273-3021
Email: [fcal@fcal.fujitsu.com](mailto:fcals@fcal.fujitsu.com)
Web: <http://www.fujitsu.com/sg/services/micro/components/>

©2009 Fujitsu Components America, Inc. All rights reserved. All trademarks or registered trademarks are the property of their respective owners.

Fujitsu Components America or its affiliates do not warrant that the content of datasheet is error free. In a continuing effort to improve our products Fujitsu Components America, Inc. or its affiliates reserve the right to change specifications/datasheets without prior notice.
Rev. November 20, 2009.