



DOC#:01.13.00A100

YDLIDAR OS30A DATA SHEET

www.ydlidar.com

CONTENTS

1 PRODUCT DESCRIPTION AND FEATURES	1
1.1 Product Description	1
1.2 Features	1
1.3 Multi-platform support	1
2 MANUAL	1
2.1 Document Purpose and Scope	1
2.2 Terminology.....	2
2.3 Introduction to Structured Light 3D Imaging Technology	2
2.4 Depth Camera System Framework.....	3
3 PRODUCT OVERVIEW	3
3.1 Appearance.....	3
3.2 Product Specifications	4
4 CAMERA SYSTEM COMPONENTS	5
4.1 System Components Table	5
4.2 Dot Projector	5
4.3 IR Camera.....	5
5 DEPTH DATA ACCURACY	6
6 APPLICATION	7
7 STRUCTURAL DESCRIPTION	8
7.1 Structural dimension drawings.....	8
7.2 Structural installation advice.....	8
7.3 Cooling Recommendations.....	8
7.4 Optical Requirements for Protective Covers.....	8
8 ELECTRONIC DESIGN	9
8.1 Power and Power Consumption.....	9
8.2 ESD Handling Recommendations.....	10
8.3 Wire Recommendations.....	10
9 SOFTWARE SDK	10
10 ATTENTION	10
11 REVISION	12

1 PRODUCT DESCRIPTION AND FEATURES

1.1 Product Description

The OS30A 3D camera module uses the binocular structured light 3D imaging technology to obtain depth images and realizes the function of depth information modeling. And it is equipped with a dedicated depth calculation chip and is optimized for robot obstacle avoidance.

The camera is compact in size, easy to integrate, and has a type C standard output interface, providing users with a high degree of flexibility. It can be adapted to complex environments such as total darkness environment, indoor strong light and weak light, backlight and smooth light, and semi-outdoor, and has a wide range of uses.

1.2 Features

- 1280*920 high resolution image output
- Depth map horizontal direction FOV 78 degrees, meet the requirement of robots
- Fearless ambient light interference
- Deep calculation processors use high-performance dedicated chips
- USB2.0 standard output interface

1.3 Multi-platform support

- Linux
 - Support X86 Ubuntu 18.14 or later
 - RK3399 Linux
 - TX2 Linux
- Android
- Windows 10
- ROS

2 MANUAL

2.1 Document Purpose and Scope

This document introduces the specifications of the OS30A 3D module product, as well as some design details for developers to understand and use related products.

2.2 Terminology

CHART 1 TERMINOLOGY

Terminology	Description
Baseline	Binocular structured light: the distance between the imaging centers of two infrared cameras
Depth	Depth video streams are like color video streams, each pixel has a value representing the distance from the camera instead of color information
FOV	Field of view, which describes the angular range over which the camera images a given scene, including horizontal field of view (H FOV)、vertical field of view (V FOV) and diagonal field of view(D FOV)
Depth processor	Depth calculation processors
IR camera	Infrared camera
RGB camera	Color camera
Dot projector	IR projector, also known as infrared laser projector, structured light projector, etc., used to emit structured light patterns
Depth camera	Depth camera, including depth imaging module and color imaging module, the depth imaging module generally consists of an infrared projector, an infrared camera and a depth calculation processor, and the color imaging modules generally refer to color cameras
I ² C	The I ² C bus is a simple, bidirectional two-wire synchronous serial bus developed by Philips. It requires only two wires to transfer information between devices connected to the bus
ISP	Image signal processor for post-processing of images
Lens	Lens, for imaging in infrared cameras, color cameras, and for projection in laser projectors
MIPI	MIPI (Mobile Industry Processor Interface) alliance. MIPI is an open standard and a specification for mobile application processors initiated by the MIPI Alliance
SoC	System on Chip, means that it is a product, an integrated circuit with a dedicated target, which contains the complete system and has the entire contents of the embedded software
ASIC	An ASIC is considered to be an integrated circuit designed for a special purpose. ASIC refers to an integrated circuit designed and manufactured in response to specific user requirements and the needs of specific electronic systems. It is characterized by specific applications

2.3 Introduction to Structured Light 3D Imaging Technology

The binocular 3D camera mainly includes two IR camera、Dot projector and depth processor. The dot projector is used to project a structured light pattern (speckle pattern) to the target scene (Scene), and two infrared cameras collect the structured light image of the target and execute the depth calculation algorithm to output the depth image of the target scene. Furthermore, when performing the depth calculation, the depth calculation processor calculates the parallax according to the difference between the deviation values of the left and right camera pixels, and then obtains the depth value.

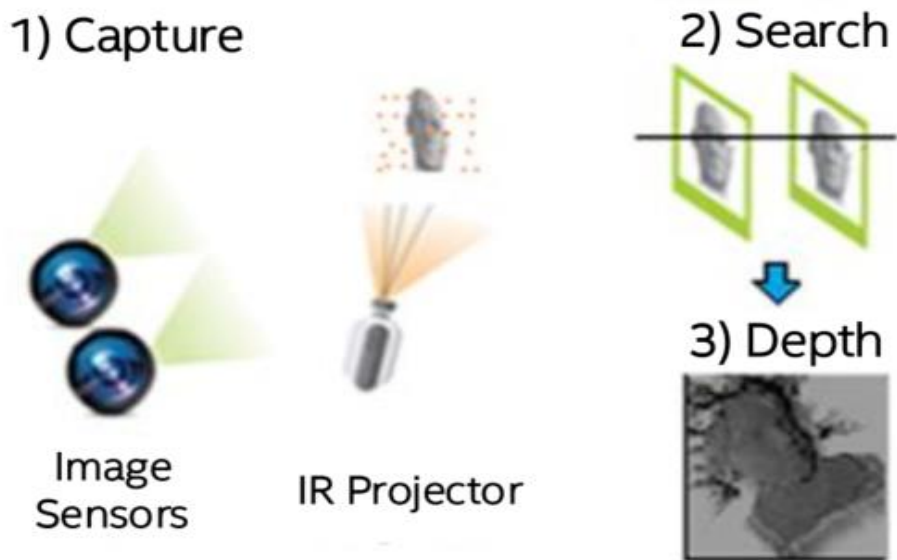

FIG 1 IMAGING SCHEMATIC

2.4 Depth Camera System Framework

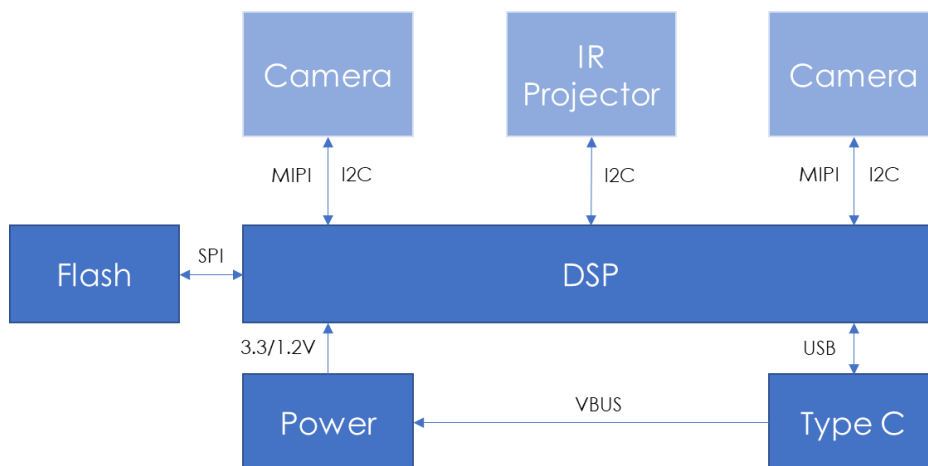

FIG 2 DEPTH CAMERA SYSTEM FRAMEWORK

3 PRODUCT OVERVIEW

3.1 Appearance



FIG 3 PRODUCT APPEARANCE

3.2 Product Specifications

CHART 2 PRODUCT SPECIFICATIONS

Items		Value	Unit	Comments
Structure	Length	90	mm	/
	Width	25.5	mm	/
	Height	25	mm	/
	Interface	USB2.0	/	Type-C with screw lock
	Weight	96	g	/
Performance	Detection distance	20-250	cm	Depending on ambient lighting and other conditions
	Accuracy Error	<1.5	cm	1m
	Resolution1	1280*920	Pixel	depth map
	Resolution2	640*460	Pixel	depth map
	HFOV	78±3	Deg	/
	VFOV	60±3	Deg	/
	Power	1.5	W	Operating typical value
Optics	Baseline	45	mm	/
Active light source	Spectrum	830-850	nm	/
	Power	<1.5	W	/
Obstacle avoidance performance	Obstacle avoidance distance	20-250	cm	Depending on ambient lighting and other conditions
Dust-proof and waterproof	Dust-proof and waterproof	IP65	/	With customized wire
ESD	Contact discharge	+/-8	KV	/
	Antiaircraft	+/-12	KV	/
Working environment	Operating temperature	-10~50	°C	/
	Operating humidity	0~80	RH	/
	storage temperature	-20~80	°C	/

4 CAMERA SYSTEM COMPONENTS

4.1 System Components Table

CHART 3 SYSTEM COMPONENTS TABLE

Camera model	OS30A
Dot Projector*1	√
IR Camera*2	√
Depth Processor*1	√

4.2 Dot Projector

Laser dot projectors acquire texture by projecting a speckle pattern. And the laser dot projector meets Class I laser safety standards under normal operation.

CHART 4 LASER DOT PROJECTOR SPECIFICATIONS

Attributes	Description
Encoding type	random speckle
Number of laser dots	>10000
Laser wavelength	830-850nm
Wavelength temperature drift	0.07nm/°C
Field of View (FOV)	>80°
Laser Safety Level	Class I

4.3 IR Camera

The infrared camera is mainly used to collect the laser lattice projected by the laser lattice projector.

CHART 5 IR CAMERA SPECIFICATIONS

Attributes	Description
Valid resolution	1280*920
Focus mode	Fixed focus
Shutter type	Progressive exposure
FOV	H78°*V60.4°
Filter	800nm-850nm narrowband filtering

5 DEPTH DATA ACCURACY

CHART 6 DEPTH DATA ACCURACY

Z (cm)	detZ (cm)	detZ/Z (%)	d	Optical Blind Spot	PW (cm)	PH (cm)	Grid-PW (cm)	Grid-PH (cm)
20	0.06	0.28%	177.825	2.78	32.39	23.28	0.03	0.03
30	0.13	0.42%	118.550	2.78	48.59	34.92	0.04	0.04
40	0.22	0.56%	88.913	2.78	64.78	46.56	0.05	0.05
50	0.35	0.70%	71.130	2.78	80.98	58.20	0.06	0.06
60	0.51	0.84%	59.275	2.78	97.17	69.84	0.08	0.08
70	0.69	0.98%	50.807	2.78	113.37	81.48	0.09	0.09
80	0.90	1.12%	44.456	2.78	129.57	93.13	0.10	0.10
90	1.14	1.27%	39.517	2.78	145.76	104.77	0.11	0.11
100	1.41	1.41%	35.565	2.78	161.96	116.41	0.13	0.13
110	1.70	1.55%	32.332	2.78	178.15	128.05	0.14	0.14
120	2.02	1.69%	29.638	2.78	194.35	139.69	0.15	0.15
130	2.38	1.83%	27.358	2.78	210.54	151.33	0.16	0.16
140	2.76	1.97%	25.404	2.78	226.74	162.97	0.18	0.18
150	3.16	2.11%	23.710	2.78	242.94	174.61	0.19	0.19
160	3.60	2.25%	22.228	2.78	259.13	186.25	0.20	0.20
170	4.06	2.39%	20.921	2.78	275.33	197.89	0.22	0.22
180	4.56	2.53%	19.758	2.78	291.52	209.53	0.23	0.23
190	5.08	2.67%	18.718	2.78	307.72	221.17	0.24	0.24
200	5.62	2.81%	17.783	2.78	323.91	232.81	0.25	0.25
210	6.20	2.95%	16.936	2.78	340.11	244.45	0.27	0.27
220	6.80	3.09%	16.166	2.78	356.30	256.09	0.28	0.28
230	7.44	3.23%	15.463	2.78	372.50	267.73	0.29	0.29
240	8.10	3.37%	14.819	2.78	388.70	279.38	0.30	0.30
250	8.79	3.51%	14.226	2.78	404.89	291.02	0.32	0.32

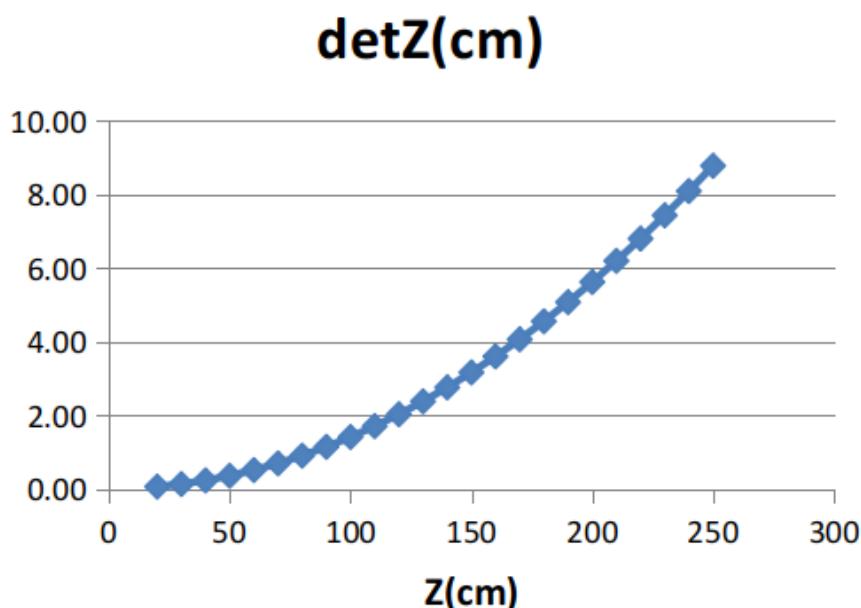

FIG 4-1

detZ/Z(%)

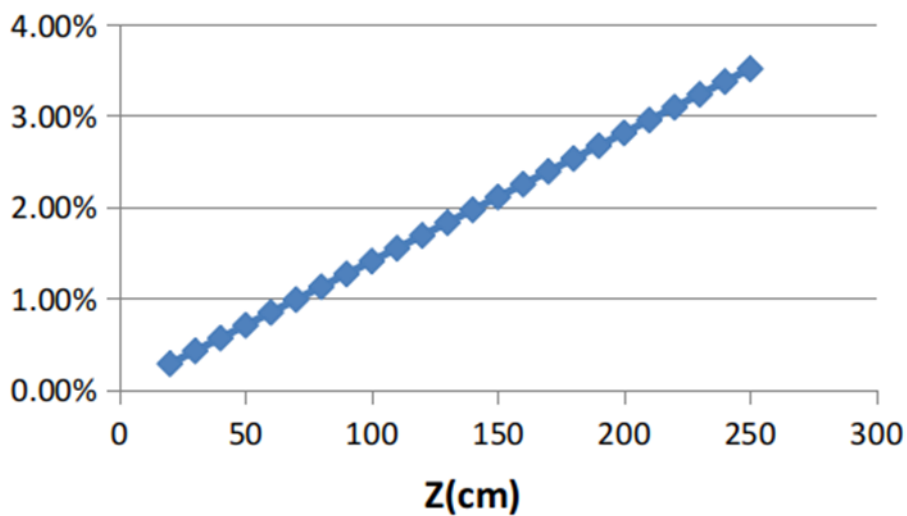

FIG 4-2

6 APPLICATION

CHART 7 APPLICATION

Field	Application
Robot	Obstacle avoidance, perception safety system
Security	Surveillance, the number of statistics, face tracking
Facial recognition	Face payment, face authentication, face access control, face attendance, etc
Industry	Industrial automation of parts scanning detection sorting
3D scanning	Indoor scanning modeling
Game	Somatosensory game, gesture interaction

7 STRUCTURAL DESCRIPTION

7.1 Structural dimension drawings

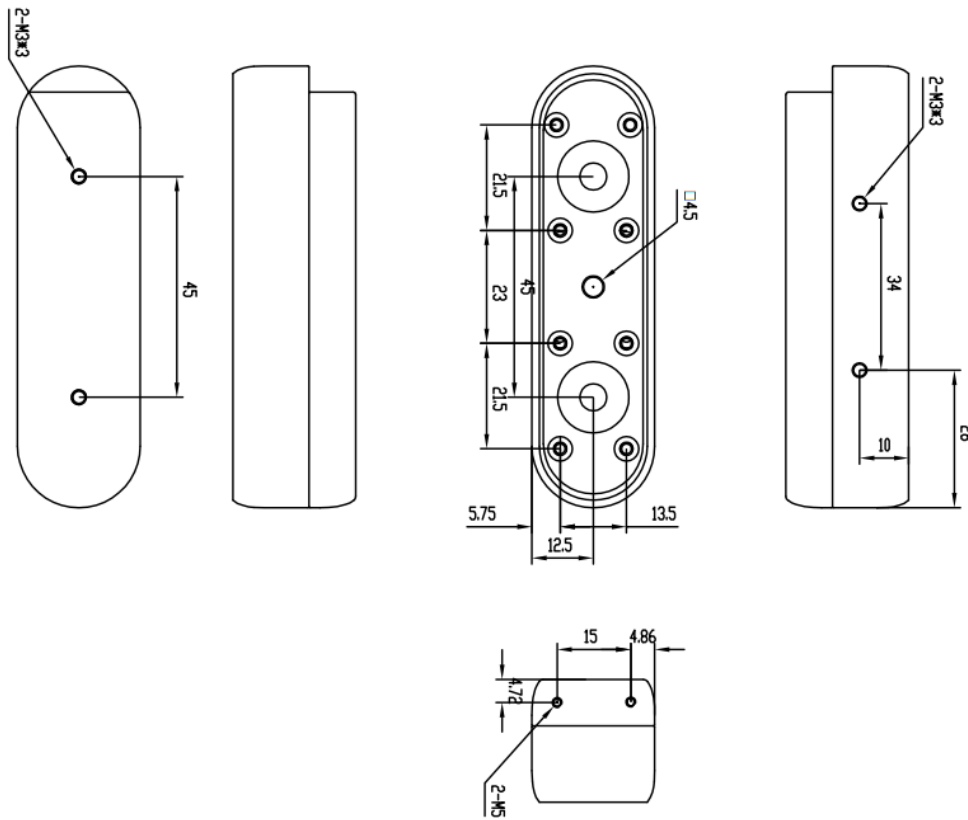

FIG 5 STRUCTURAL DIMENSION DRAWINGS

7.2 Structural installation advice

1. The front and back of the camera are pressed by foam, and the side is closely matched with the screens structure.
2. Reserve 2 M3 screw holes on the back for fixing.
3. Reserve 2 M3 groundings on the bottom.

7.3 Cooling Recommendations

1. Connect the casing of the camera to the metal part of the whole device, which is beneficial to reduce the ambient temperature of the hardware.
2. Increase the space around the camera as much as possible, so that the camera has more space for conventional heat dissipation.

7.4 Optical Requirements for Protective Covers

When the module is integrated into the whole device, it is forbidden to cover glass or other obstructions in front of the module. If an additional protective cover is necessary to be added, the following requirements have to be met:

1. The front protective cover of the whole machine needs to meet the following requirements:

- a) Material of protective cover: glass or PC/PMMA.
 - b) The transmittance area of the protection cover plate corresponding to Dot projector and infrared camera should be silk-screened for windowing, and the size can refer to the FOV of each device in the drawings provided by EAI, or according to the actual product structure, on the basis of satisfying the field of view of the device, the unilateral expansion is greater than or equal to 0.5mm.
 - c) Optical transmittance:
 - d) Dot projector transparent area: 800-1050nm wave band, global minimum transmittance $T_{min} \geq 92\%$.
 - e) IR camera transparent area: 800-1050nm wave band, global minimum transmittance $T_{min} \geq 92\%$.
 - f) It is recommended to carry out AF coating treatment on the outer surface of the protective cover, to prevent fingerprints and oil stains in the actual use scene from affecting the product effect.
2. Structural and dimension requirements of the protective cover:
 - a) When the material is PC/PMMA, the thickness is designed to be $\geq 1.5\text{mm}$ or more to prevent deformation under force.
 - b) When the material is glass, the thickness is designed to be 0.3-1.0mm.
 - c) The air gap between the protective cover and each optical device is less than 0.5mm.
 - d) Requirements for the flatness of the protective cover: $< 0.005\text{mm}$.
 3. Instructions for anti-fingerprint and oil stains:
 - a) In the process of assembling the module to the whole device, the surface of each optical device should be strictly dust-proof and anti-fouling.
 - b) When using the whole device, pay attention to the outer surface of the protective cover should be clean, so as not to affect the effect of the product.
 4. If a protective film is attached to the outer surface of the protective cover, it is necessary to hollow out and avoid the corresponding two device window areas on the protective film, otherwise the light transmittance will be seriously affected.

8 ELECTRONIC DESIGN

8.1 Power and Power Consumption

The camera product is powered by USB, and the peak current of the laser is high, so it must be powered by a USB interface of 5V/1.5A or above. If the current is lower than 5V/1.5A, the device may not be able to start. When the camera is working, make sure that the voltage drop of the USB cable is $< 0.3\text{V}$.

CHART 8 POWER CONSUMPTION TABLE

Preconditions	Consumption (W)	Voltage (V)	Current (A)
Average working power consumption	1.5	5.20	0.3

8.2 ESD Handling Recommendations

The camera is an ESD sensitive device and needs to be protected against ESD during production, transportation, and assembly. The details are as follows:

1. During the production process, operators are advised to wear ESD anti-static wristbands throughout the process.
2. The camera is recommended to be placed in an ESD anti-static bag for transportation or transfer.

8.3 Wire Recommendations

The communication of the camera relies on the high-speed USB 2.0 signal. In order to ensure the stability and reliability of the signal transmission, it is recommended that the client make the cable according to the requirements. Shielding: The first layer of shielding, the outer shielding metal mesh needs to wrap the entire line, the recommended density is not less than 7 mesh, and it is connected to the metal shell of the two interfaces. Further more, for the second layer of shielding, it is recommended that the outer shielding metal mesh should be covered with a layer of aluminum foil, and the aluminum foil is in contact with the metal mesh.

The material of the transmission line: the outer metal shielding net, the inner cable of the USB 2.0 group and other signal transmission lines are recommended to be tinned copper.

The thickness of the transmission line: 28# is recommended for USB signal lines, not less than 30# as far as possible, 22# for power and ground lines, and not less than 24# is recommended.

9 SOFTWARE SDK

Provides SDKs related to Windows, Linux, and Android platforms. Please contact FAE for the latest SDK.

10 ATTENTION

1. Please operate the device correctly according to the guidelines, if illegal operation may cause damage to the internal components.
2. Do not drop or hit the product to prevent damage to internal components and loss of accuracy;
3. Do not attempt to modify or disassemble this device in any way, so as to avoid damage to the camera and decrease in accuracy.
4. It is normal for the temperature of the product to rise after a period of use.
5. Do not touch the lens, so as not to leave objects and affect the effect of the picture.
6. Do not place the product where children or animals can touch it to avoid accidents.

7. It is suggested that the USB power supply interface connecting the mainboard to this module should be reserved for design larger than 5V&1.5A.
8. For the selection of USB cable, it is necessary to carefully evaluate the cable to ensure that there will be no unstable factors caused by the length, material, thickness, etc.
9. For structural design, heat dissipation design, and electronic design (including electromagnetic interference, etc.), please communicate with EAI engineers in advance to improve product design.

11 REVISION

Date	Version	Content
2022-09-01	1.0	The 1st release