

# SB-AQ8-02

## FIS GAS SENSOR SB-AQ8-02 for AIR QUALITY CONTROLS (VOCs)

The SB-AQ8 is a tungsten trioxide semiconductor gas sensor which has a very high sensitivity to VOCs, solvents and many other gases. This model is suitable for air quality monitoring for general applications.

### Structure

Gas sensitive semiconductor material is a mini bead type and a heater coil and electrode wire are embedded in the element. The sensing element is installed in the metal housing which uses double stainless steel mesh (100 mesh) in the path of gas flow. The mesh is an anti-explosion feature (Fig1).

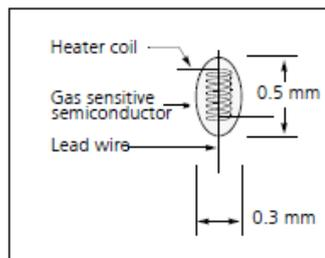

Fig 1a. Sensing element

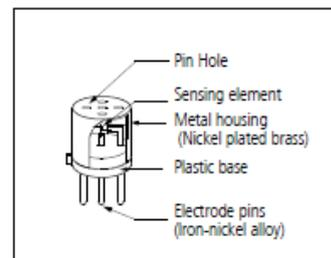

Fig 1b. Configuration

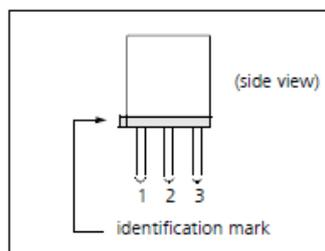

Fig 1c. Pin Layout

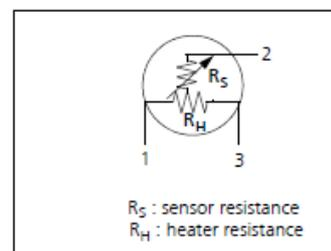

Fig 1d. Equivalent circuit

### Operating conditions

Fig 2 shows the standard operating circuit for this model. The change of the sensor resistance ( $R_S$ ) is obtained as the change of the output voltage across the fixed or variable resistor ( $R_L$ ). In order to obtain the best performance and specified characteristics, the values of the heater voltage ( $V_H$ ) circuit voltage ( $V_C$ ) and load resistance ( $R_L$ ) must be within the range of values given in the standard operating conditions shown in the Specification table on the next page.

### Sensitivity characteristics

Fig 3 shows the sensitivity characteristics curves of the SB-AQ8 (typical data). Sensitivity characteristics of the FIS gas sensors are expressed by the relationship between the sensor resistance and gas concentration. The sensor resistance decreases with an increase of gas concentration based on a logarithmic function.

The sensitivity characteristics of the SB-AQ8 is specified by the following parameters.

- Sensor resistance level: at clean air
- Sensor resistance change Ratio: between Ethanol 10ppm and in air

See the specification table on the next page for further details.

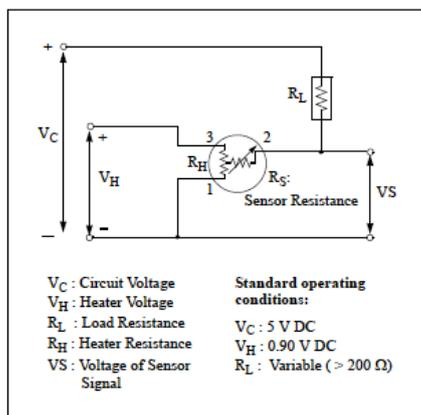

Fig 2. Standard circuit

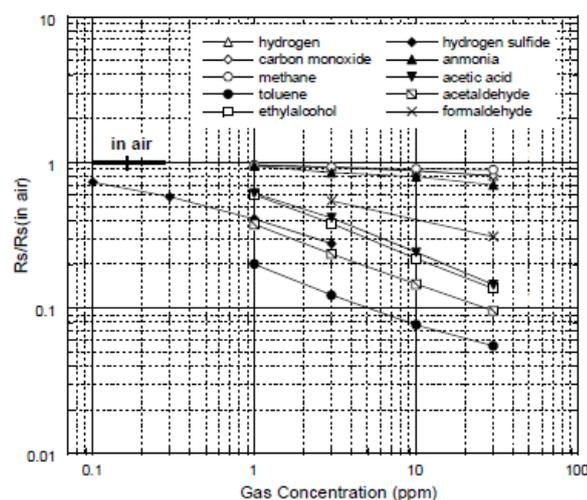

Fig3. Sensitivity characteristics

# Specifications

## A. Standard Operating conditions

Symbol	Parameter	Specification	Conditions etc.
VH	Heater voltage	0.9 V ± 0.05 V	AC, DC or pulse
VC	Circuit voltage	Less than 5 V	DC: Pin2 (+) - Pin 1 (-)
RL	Load resistance	Variable (> 200 Ω)	P <sub>S</sub> < 10 mW
RH	Heater resistance	2.8 Ω ± 0.2 Ω	at room temperature
IH	Heater current	130mA	IH = VH / RH
PH	Heater power consumption	120 mW	PH = VH <sup>2</sup> / RH
PS	Power dissipation of sensing element	Less than 10mW	$P_S = \frac{(V_C - V_{RL})^2}{R_S}$

## B. Environmental conditions

Symbol	Parameter	Specification	Conditions etc.
T <sub>ao</sub>	Operating temperature	-10 °C to 60 °C	
T <sub>as</sub>	Storage temp	-20 °C to 70 °C	
RH	Relative humidity	Less than 95%RH	
(O <sub>2</sub> )	Oxygen concentration	21% ± 1% (Standard condition) The sensitivity characteristics are influenced by the variation in oxygen concentration. Please consult FIS for details.	Absolute minimum level : more than 18%.

## C. Sensitivity characteristics

Model	SB-AQ8-02		
Symbo	Parameter	Specification	Conditions etc.
RS	Sensor resistance	45kΩ to 180 kΩ	at clean air
Acetone selectivity		0.10 to 0.50	$\frac{R_s \text{ at Ethanol } 10\text{ppm}}{R_s \text{ in air}}$
Standard Test Conditions: Temp : 20°C±2°C      VC : 5.0 V ± 1 % Humidity : 65%±5%      VC : 0.9 V ± 1 % (in clean air)      RL : 10 kΩ ± 5% Pre-heating time: more than 48 hours			

## Dimensions

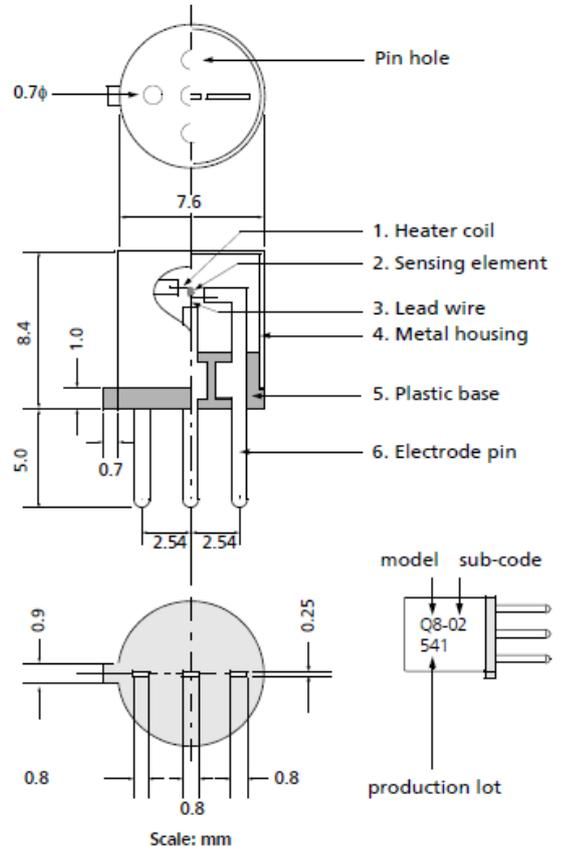

Weight : 0.6g

## D. Mechanical characteristics

No.	Parts	Materials
Vibration	Frequency : 5 - 500 Hz Acceleration : 1.3 G Sweep Time : 40 min.	Should satisfy the specifications shown in the sensitivity characteristics after test.
Drop	Height : 60 cm Number of impacts : 3 times	

## E. Parts and Materials

No.	Parts	Materials
1	Heater coil	Platinum
2	Sensing element	Tungsten oxide
3	Lead wire	Platinum
4	Metal housing	Nickel plated brass
5	Plastic base	PBT (GF30%)
6	Electrode pin	Iron-nickel alloy

## Please contact

November, 2016

FIS Inc.  
3-36-3, Kitazono  
Itami, Hyogo  
664-0891 Japan

Tel: +81-72-780-1800  
Fax: +81-72-785-0073  
<http://www.fisinc.co.jp>

In the interest of continued product improvement, we reserve the right to change design features without prior notice.