

FEATURES

- Complete NiMH/NiCd Charger for 1 to 16 Cells
- No Microcontroller or Firmware Required
- 550kHz Synchronous PWM Current Source Controller
- No Audible Noise with Ceramic Capacitors
- PowerPath™ Control Support
- Programmable Charge Current: 5% Accuracy
- Wide Input Voltage Range: 4.5V to 34V
- Automatic Trickle Precharge
- $-\Delta V$ Fast Charge Termination
- Optional $\Delta T/\Delta t$ Fast Charge Termination
- Automatic NiMH Top-Off Charge
- Programmable Timer
- Automatic Recharge
- Multiple Status Outputs
- Micropower Shutdown
- 20-Lead Thermally Enhanced TSSOP Package

APPLICATIONS

- Integrated or Standalone Battery Charger
- Portable Instruments or Consumer Products
- Battery-Powered Diagnostics and Control
- Back-Up Battery Management

LT, LT, LTC, LTM, Linear Technology and the Linear logo are registered trademarks of Linear Technology Corporation. PowerPath is a trademark of Linear Technology Corporation. All other trademarks are the property of their respective owners.

DESCRIPTION

The LTC®4011 provides a complete, cost-effective nickel battery fast charge solution in a small package using few external components. A 550kHz PWM current source controller and all necessary charge initiation, monitoring and termination control circuitry are included.

The LTC4011 automatically senses the presence of a DC adapter and battery insertion or removal. Heavily discharged batteries are precharged with a trickle current. The LTC4011 can simultaneously use both $-\Delta V$ and $\Delta T/\Delta t$ fast charge termination techniques and can detect various battery faults. If necessary, a top-off charge is automatically applied to NiMH batteries after fast charging is completed. The IC will also resume charging if the battery self-discharges after a full charge cycle.

All LTC4011 charging operations are qualified by actual charge time and maximum average cell voltage. Charging may also be gated by minimum and maximum temperature limits. NiMH or NiCd fast charge termination parameters are pin-selectable.

Integrated PowerPath control support ensures that the system remains powered at all times without allowing load transients to adversely affect charge termination.

TYPICAL APPLICATION

2A NiMH Battery Charger

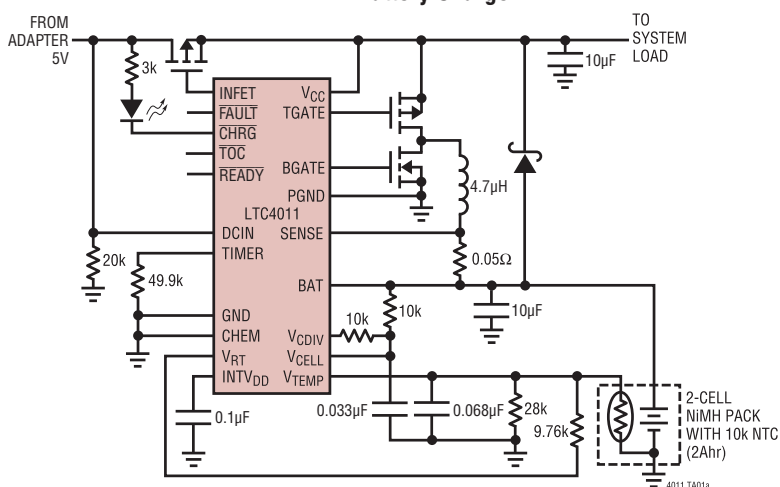

2A NiMH Charge Cycle at 1C

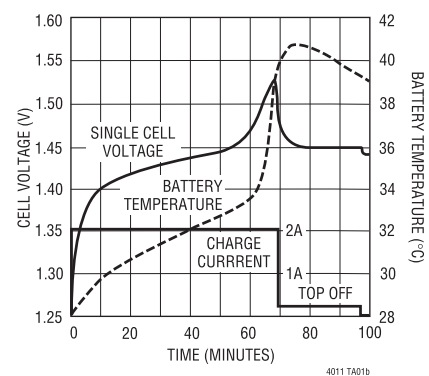

ABSOLUTE MAXIMUM RATINGS

(Note 1)

V_{CC} (Input Supply) to GND.....	-0.3V to 36V
DCIN to GND.....	-0.3V to 36V
FAULT, CHR \bar{G} , V_{CELL} , V_{CDIV} , SENSE, BAT, $\bar{T}OC$ or $\bar{R}EADY$ to GND	-0.3V to $V_{CC} + 0.3V$
SENSE to BAT	$\pm 0.3V$
CHEM, V_{TEMP} or TIMER to GND.....	-0.3V to 3.5V
PGND to GND.....	$\pm 0.3V$
Operating Ambient Temperature Range (Note 2).....	0°C to 85°C
Operating Junction Temperature (Note 3).....	125°C
Storage Temperature Range.....	-65°C to 150°C
Lead Temperature (Soldering, 10 sec)	300°C

PIN CONFIGURATION

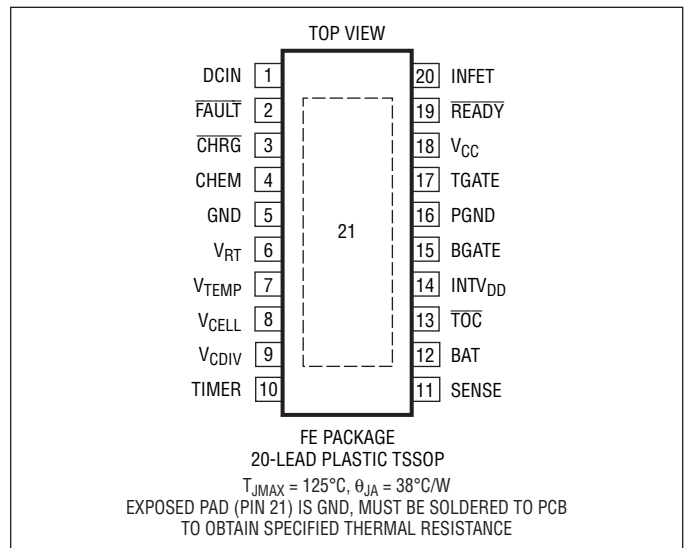

ORDER INFORMATION

LEAD FREE FINISH	TAPE AND REEL	PART MARKING	PACKAGE DESCRIPTION	TEMPERATURE RANGE
LTC4011CFE#PBF	LTC4011CFE#TRPBF	LTC4011CFE	20-Lead Plastic TSSOP	0°C to 85°C
LEAD BASED FINISH	TAPE AND REEL	PART MARKING	PACKAGE DESCRIPTION	TEMPERATURE RANGE
LTC4011CFE	LTC4011CFE#TR	LTC4011CFE	20-Lead Plastic TSSOP	0°C to 85°C

Consult LTC Marketing for parts specified with wider operating temperature ranges.

For more information on lead free part marking, go to: <http://www.linear.com/leadfree/>

For more information on tape and reel specifications, go to: <http://www.linear.com/tapeandreeel/>

ELECTRICAL CHARACTERISTICS (Note 4) The ● indicates specifications which apply over the full operating temperature range, otherwise specifications are at $T_A = 25^{\circ}C$. $V_{CC} = 12V$, $BAT = 4.8V$, $GND = PGND = 0V$, unless otherwise noted.

SYMBOL	PARAMETER	CONDITIONS	MIN	TYP	MAX	UNITS
V_{CC} Supply						
V_{CC}	Input Voltage Range		● 4.5		34	V
I_{SHDN}	Shutdown Quiescent Current (Note 5)	$V_{CC} = BAT = 4.8V$		5	10	μA
I_Q	Quiescent Current	Waiting to Charge (Pause)	●	3	5	mA
I_{CC}	Operating Current	Fast Charge State, No Gate Load	●	5	9	mA
V_{UVLO}	Undervoltage Threshold Voltage	V_{CC} Increasing	● 3.85	4.2	4.45	V
$V_{UV(HYST)}$	Undervoltage Hysteresis Voltage			170		mV
V_{SHDN1}	Shutdown Threshold Voltage	$DCIN - V_{CC}$, $DCIN$ Increasing	● 5	30	60	mV
V_{SHDND}	Shutdown Threshold Voltage	$DCIN - V_{CC}$, $DCIN$ Decreasing	● -60	-25	-5	mV
V_{CE}	Charge Enable Threshold Voltage	$V_{CC} - BAT$, V_{CC} Increasing	● 400	510	600	mV
INTV$_{DD}$ Regulator						
V_{DD}	Output Voltage	No Load	● 4.5	5	5.5	V
I_{DD}	Short-Circuit Current (Note 6)	$INTV_{DD} = 0V$	● -100	-50	-10	mA
$INTV_{DD(MIN)}$	Output Voltage	$V_{CC} = 4.5V$, $I_{DD} = -10mA$	● 3.85			V

4011fb

ELECTRICAL CHARACTERISTICS

The ● indicates specifications which apply over the full operating temperature range, otherwise specifications are at $T_A = 25^\circ\text{C}$. $V_{CC} = 12\text{V}$, $BAT = 4.8\text{V}$, $GND = PGND = 0\text{V}$, unless otherwise noted.

SYMBOL	PARAMETER	CONDITIONS		MIN	TYP	MAX	UNITS
Thermistor Termination							
V_{RT}	Output Voltage	$R_L = 10\text{k}$	●	3.075 3	3.3	3.525 3.6	V V
I_{RT}	Short-Circuit Current	$V_{RT} = 0\text{V}$	●	-9		-1	mA
PWM Current Source							
V_{FS}	BAT – SENSE Full-Scale Regulation Voltage (Fast Charge)	$0.3\text{V} < \text{BAT} < V_{CC} - 0.3\text{V}$ (Note 5) $\text{BAT} = 4.8\text{V}$	●	95 95	100 100	105 105	mV mV
V_{PC}	BAT – SENSE Precharge Regulation Voltage	$0.3\text{V} < \text{BAT} < V_{CC} - 0.3\text{V}$ (Note 5) $\text{BAT} = 4.8\text{V}$	●	16 16	20 20	24 24	mV mV
V_{TC}	BAT – SENSE Top-Off Charge Regulation Voltage	$0.3\text{V} < \text{BAT} < V_{CC} - 0.3\text{V}$ (Note 5) $\text{BAT} = 4.8\text{V}$	●	6.5 6.5	10 10	13.5 13.5	mV mV
ΔV_{LI}	BAT – SENSE Line Regulation	$5.5\text{V} < V_{CC} < 25\text{V}$, Fast Charge			± 0.3		mV
I_{BAT}	BAT Input Bias Current	$0.3\text{V} < \text{BAT} < V_{CC} - 0.1\text{V}$		-2		2	mA
I_{SENSE}	SENSE Input Bias Current	SENSE = BAT			50	150	μA
I_{OFF}	Input Bias Current	SENSE or BAT, $V_{CELL} = 0\text{V}$	●	-1	0	1	μA
f_{TYP}	Typical Switching Frequency		●	460	550	640	kHz
f_{MIN}	Minimum Switching Frequency		●	20	30		kHz
DC_{MAX}	Maximum Duty Cycle			98	99		%
$V_{OL(TG)}$	TGATE Output Voltage Low ($V_{CC} - \text{TGATE}$, Note 7)	$V_{CC} > 9\text{V}$, No Load $V_{CC} < 7\text{V}$, No Load	● ●	5 $V_{CC} - 0.5$	5.6 V_{CC}	8.75	V V
$V_{OH(TG)}$	TGATE Output Voltage High	$V_{CC} - \text{TGATE}$, No Load	●		0	50	mV
$t_{R(TG)}$	TGATE Rise Time	$C_{LOAD} = 3\text{nF}$, 10% to 90%			35	100	ns
$t_{F(TG)}$	TGATE Fall Time	$C_{LOAD} = 3\text{nF}$, 10% to 90%			45	100	ns
$V_{OL(BG)}$	BGATE Output Voltage Low	No Load	●		0	50	mV
$V_{OH(BG)}$	BGATE Output Voltage High	No Load	●	$\text{INTV}_{DD} - 0.075$	INTV_{DD}		V
$t_{R(BG)}$	BGATE Rise Time	$C_{LOAD} = 1.6\text{nF}$, 10% to 90%			35	80	ns
$t_{F(BG)}$	BGATE Fall Time	$C_{LOAD} = 1.6\text{nF}$, 10% to 90%			15	80	ns
ADC Inputs							
I_{LEAK}	Analog Channel Leakage	$0\text{V} < V_{CELL} < 2\text{V}$, $550\text{mV} < V_{TEMP} < 2\text{V}$			± 100		nA
Charger Thresholds							
V_{BP}	Battery Present Threshold Voltage		●	320	350	370	mV
V_{BOV}	Battery Overvoltage		●	1.815	1.95	2.085	V
V_{MFC}	Minimum Fast Charge Voltage		●	850	900	950	mV
V_{FCBF}	Fast Charge Battery Fault Voltage		●	1.17	1.22	1.27	V
ΔV_{TERM}	$-\Delta V$ Termination	CHEM OPEN (NiCd) CHEM = 0V (NiMH)	● ●	16 6	20 10	25 14	mV mV
V_{AR}	Automatic Recharge Voltage	V_{CELL} Decreasing	●	1.260	1.325	1.390	V
ΔT_{TERM}	ΔT Termination (Note 8)	CHEM = 3.3V (NiCd) CHEM = 0V (NiMH)	● ●	1.3 0.5	2 1	2.7 1.5	$^\circ\text{C}/\text{min}$ $^\circ\text{C}/\text{min}$
T_{MIN}	Minimum Charging Temperature (Note 8)	V_{TEMP} Increasing	●	0	5	9	$^\circ\text{C}$
T_{MAXI}	Maximum Charge Initiation Temperature (Note 8)	V_{TEMP} Decreasing, Not Charging	●	41.5	45	47	$^\circ\text{C}$

ELECTRICAL CHARACTERISTICS

The ● indicates specifications which apply over the full operating temperature range, otherwise specifications are at $T_A = 25^\circ\text{C}$. $V_{CC} = 12\text{V}$, $BAT = 4.8\text{V}$, $GND = PGND = 0\text{V}$, unless otherwise noted.

SYMBOL	PARAMETER	CONDITIONS		MIN	TYP	MAX	UNITS
T_{MAXC}	Maximum Fast Charge Temperature (Note 8)	V_{TEMP} Decreasing, Fast Charge	●	57	60	63	$^\circ\text{C}$
$V_{TEMP(D)}$	V_{TEMP} Disable Threshold Voltage		●	2.8		3.3	V
$V_{TEMP(P)}$	Pause Threshold Voltage		●	130		280	mV

Charger Timing

Δt_{TIMER}	Internal Time Base Error		●	-10		10	%
Δt_{MAX}	Programmable Timer Error	$R_{TIMER} = 49.9\text{k}$	●	-20		20	%

PowerPath Control

V_{FR}	INFET Forward Regulation Voltage	$DCIN - V_{CC}$	●	15	55	100	mV
$V_{OL(INFET)}$	Output Voltage Low	$V_{CC} - \text{INFET}$, No Load	●	3.75	5.2	7	V
$V_{OH(INFET)}$	Output Voltage High	$V_{CC} - \text{INFET}$, No Load	●		0	50	mV
$t_{OFF(INFET)}$	INFET OFF Delay Time	$C_{LOAD} = 10\text{nF}$, INFET to 50%			3	15	μs

Status and Chemistry Select

V_{OL}	Output Voltage Low ($I_{LOAD} = 10\text{mA}$)	V_{CDIV} All Other Status Outputs	● ●		435 300	700 600	mV mV
I_{LKG}	Output Leakage Current	All Status Outputs Inactive, $V_{OUT} = V_{CC}$	●	-10		10	μA
$I_{IH(VCDIV)}$	Input Current High	$V_{CDIV} = V_{BAT}$ (Shutdown)	●	-1		1	μA
V_{IL}	Input Voltage Low	CHEM (NiMH)	●			900	mV
V_{IH}	Input Voltage High	CHEM (NiCd)	●	2.85			V
I_{IL}	Input Current Low	CHEM = GND	●	-20		-5	μA
I_{IH}	Input Current High	CHEM = 3.3V	●	-20		20	μA

Note 1: Stresses beyond those listed under Absolute Maximum Ratings may cause permanent damage to the device. Exposure to any Absolute Maximum Rating condition for extended periods may affect device reliability and lifetime.

Note 2: The LTC4011C is guaranteed to meet performance specifications from 0°C to 70°C . Specifications over the 0°C to 85°C operating temperature range are assured by design, characterization and correlation with statistical process controls.

Note 3: Operating junction temperature T_J (in $^\circ\text{C}$) is calculated from the ambient temperature T_A and the total continuous package power dissipation P_D (in watts) by the formula:

$$T_J = T_A + \theta_{JA} \cdot P_D$$

Refer to the Applications Information section for details. This IC includes overtemperature protection that is intended to protect the device during momentary overload conditions. Junction temperature will exceed 125°C

when overtemperature protection is active. Continuous operation above the specified maximum operating junction temperature may result in device degradation or failure.

Note 4: All current into device pins is positive. All current out of device pins is negative. All voltages are referenced to GND, unless otherwise specified.

Note 5: These limits are guaranteed by correlation to wafer level measurements.

Note 6: Output current may be limited by internal power dissipation. Refer to the Applications Information section for details.

Note 7: Either TGATE V_{OH} may apply for $7.5\text{V} < V_{CC} < 9\text{V}$.

Note 8: These limits apply specifically to the thermistor network shown in Figure 5 in the Applications Information section with the values specified for a 10k NTC (β of 3750). Limits are then guaranteed by specific V_{TEMP} voltage measurements during test.

TYPICAL PERFORMANCE CHARACTERISTICS

NiCd Charge Cycle at 1C

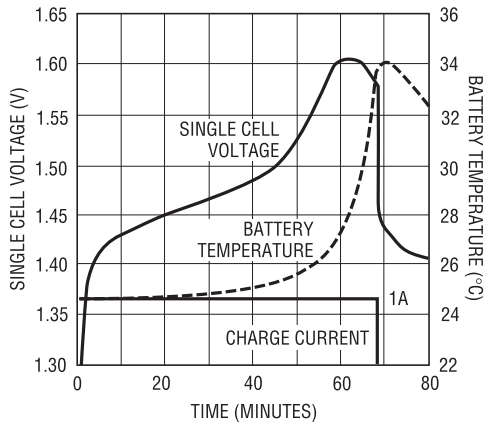

4011 G01

NiCd Charge Cycle at 2C

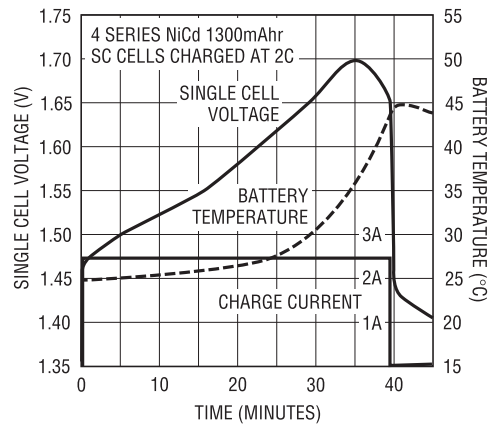

4011 G02

NiMH Charge Cycle at 0.5C

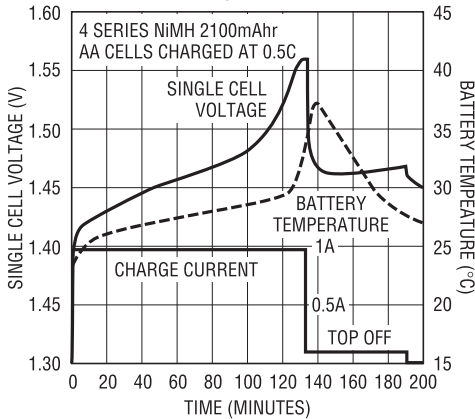

4011 G03

Battery Present Threshold Voltage (per Cell)

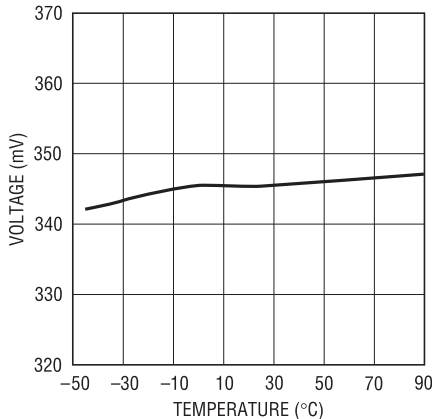

4011 G04

Minimum Fast Charge Threshold Voltage (per Cell)

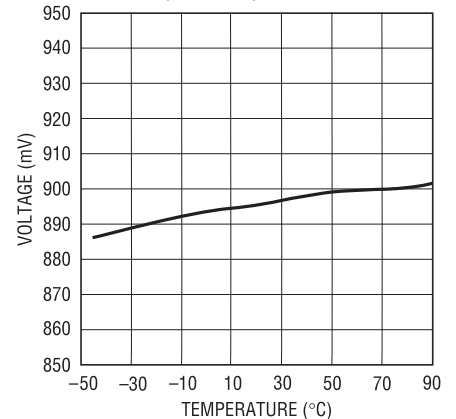

4011 G05

Automatic Recharge Threshold Voltage (per Cell)

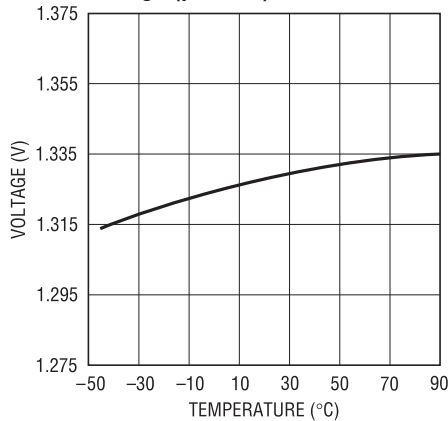

4011 G06

Battery Overvoltage Threshold Voltage (per Cell)

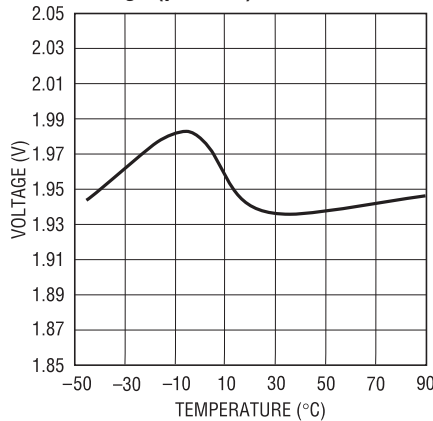

4011 G07

-ΔV Termination Voltage (per Cell)

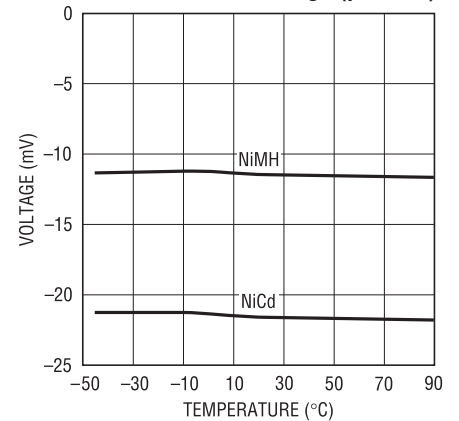

4011 G08

TYPICAL PERFORMANCE CHARACTERISTICS

Programmable Timer Accuracy

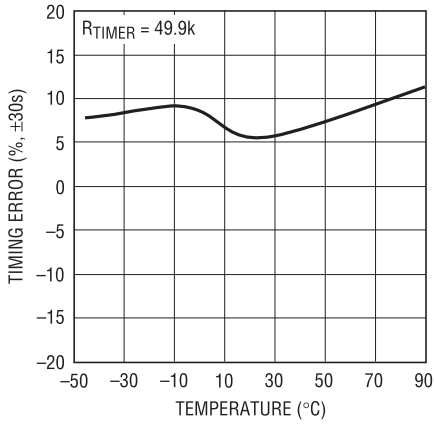

4011 G09

Charge Current Accuracy

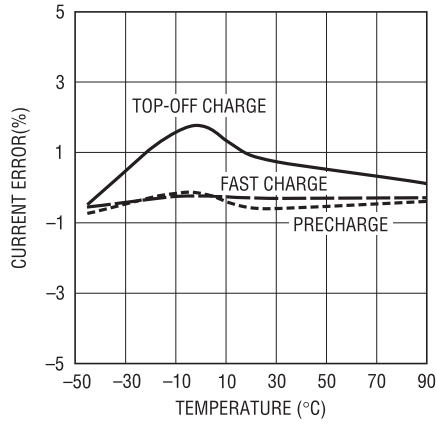

4011 G10

PWM Switching Frequency

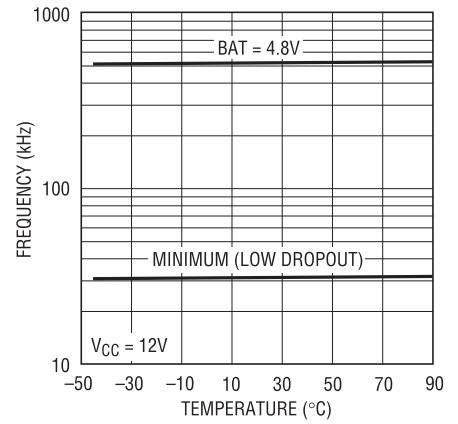

4011 G11

Charger Efficiency at $I_{OUT} = 2A$

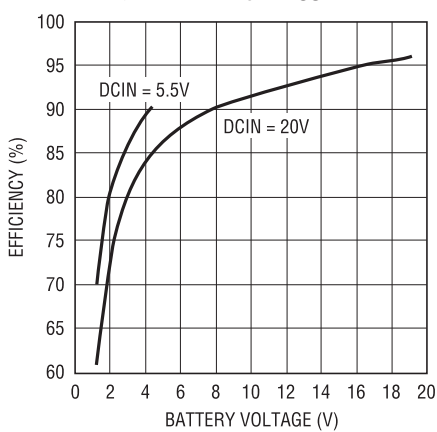

4011 G12

Charger Soft-Start

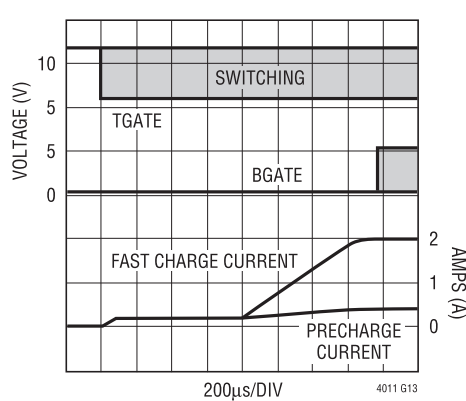

4011 G13

Fast Charge Current Line Regulation

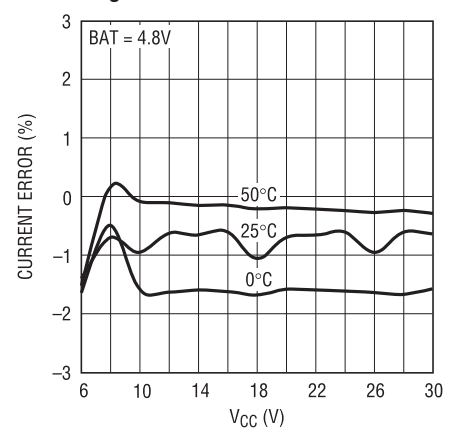

4011 G14

Fast Charge Current Output Regulation

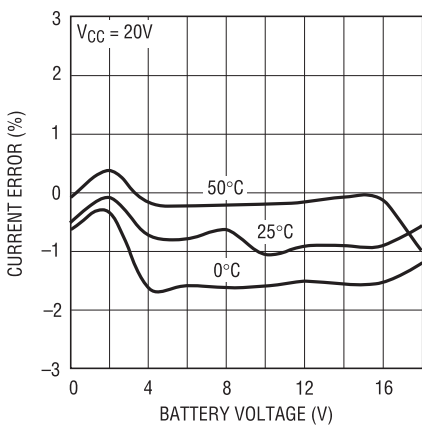

4011 G15

INFET Forward Regulation Voltage

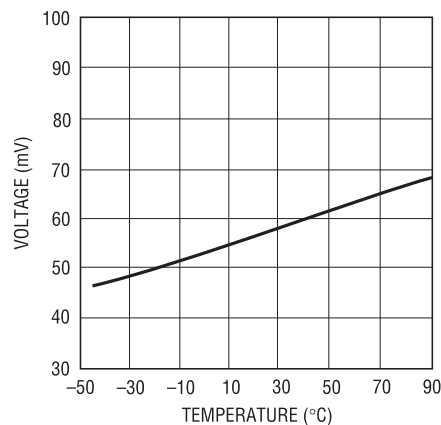

4011 G16

INFET OFF Delay Time

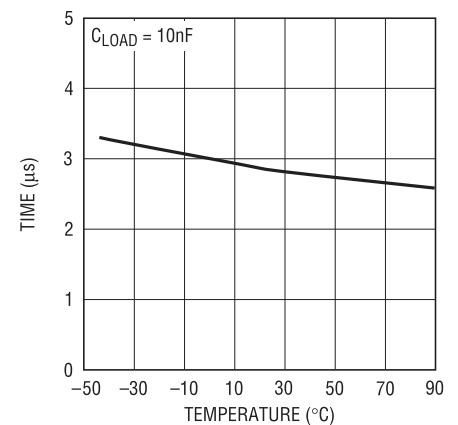

4011 G17

TYPICAL PERFORMANCE CHARACTERISTICS

PowerPath Switching

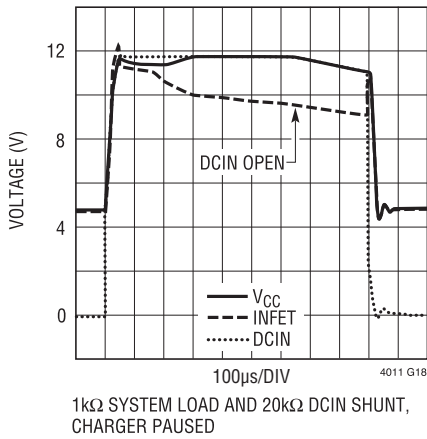

4011 G19

Shutdown Quiescent Current

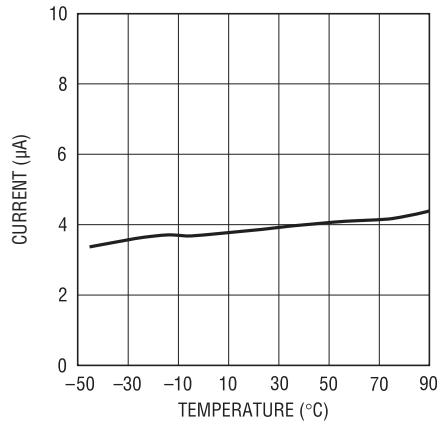

4011 G19

PWM Input Bias Current (OFF)

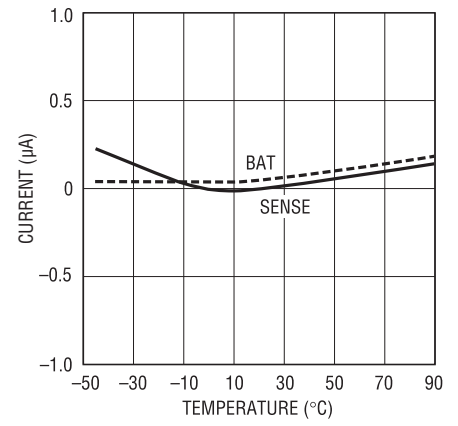

4011 G20

Undervoltage Lockout Threshold Voltage

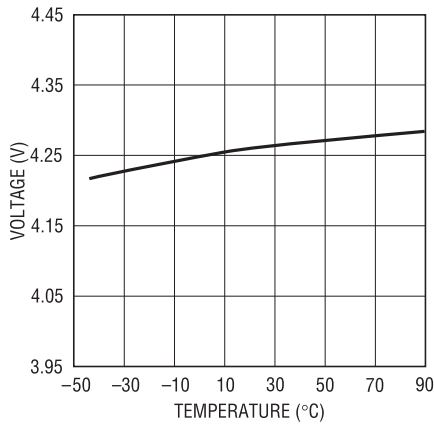

4011 G21

Shutdown Threshold Voltage (DCIN - VCC)

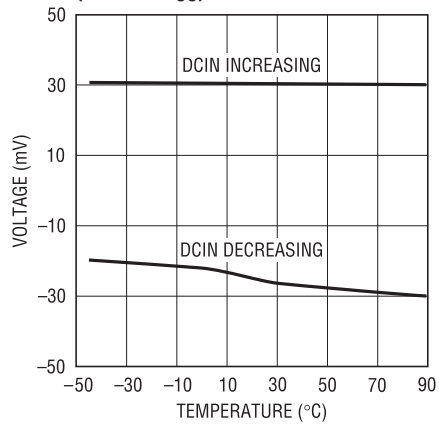

4011 G22

Charge Enable Threshold Voltage (VCC - BAT)

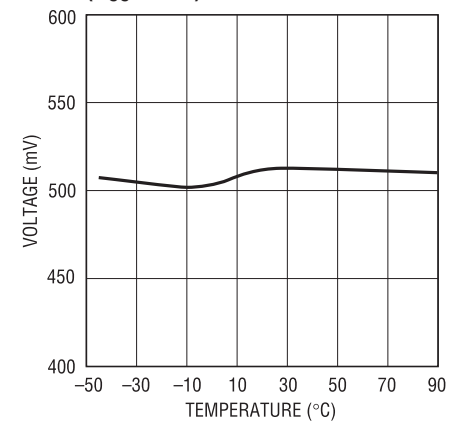

4011 G23

Thermistor Disable Threshold Voltage

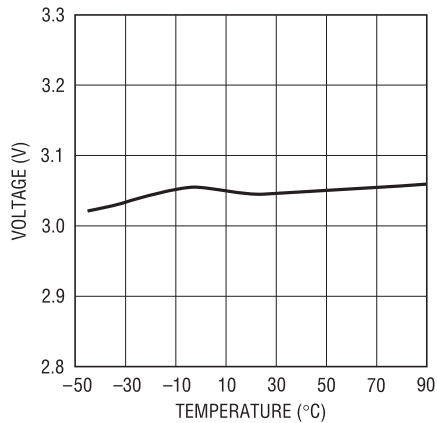

4011 G24

Pause Threshold Voltage

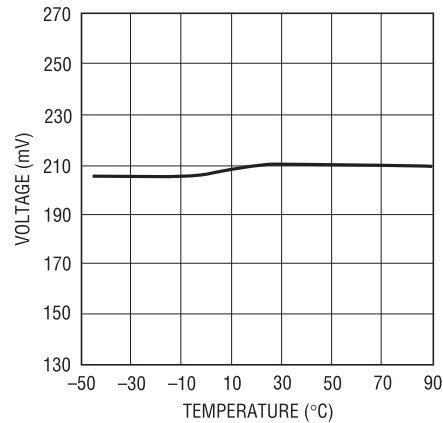

4011 G25

TYPICAL PERFORMANCE CHARACTERISTICS

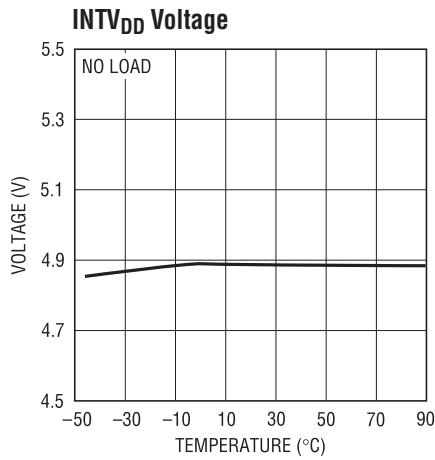

4011 G26

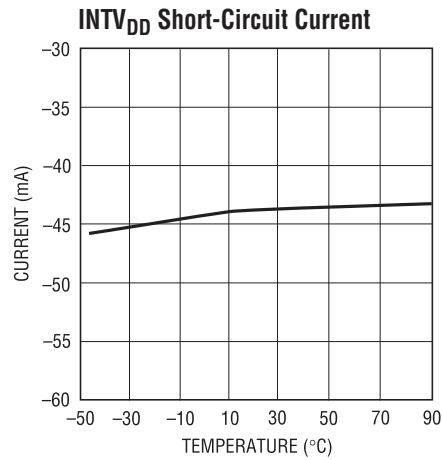

4011 G27

PIN FUNCTIONS

DCIN (Pin 1): DC Power Sense Input. The LTC4011 senses voltage on this pin to determine when an external DC power source is present. This input should be isolated from V_{CC} by a blocking diode or PowerPath FET. Refer to the Applications Information section for complete details. Operating voltage range is GND to 34V.

FAULT (Pin 2): Active-Low Fault Indicator Output. The LTC4011 indicates various battery and internal fault conditions by connecting this pin to GND. Refer to the Operation and Applications Information sections for further details. This output is capable of driving an LED and should be left floating if not used. FAULT is an open-drain output to GND with an operating voltage range of GND to V_{CC} .

CHRG (Pin 3): Active-Low Charge Indicator Output. The LTC4011 indicates it is providing charge to the battery by connecting this pin to GND. Refer to the Operation and Applications Information sections for further details. This output is capable of driving an LED and should be left floating if not used. $\overline{\text{CHRG}}$ is an open-drain output to GND with an operating voltage range of GND to V_{CC} .

CHEM (Pin 4): Battery Chemistry Selection Input. This pin should be wired to GND to select NiMH fast charge termination parameters. If a voltage greater than 2.85V is applied to this pin, or it is left floating, NiCd parameters are used. Refer to the Applications Information section for further details. Operating voltage range is GND to 3.3V.

GND (Pin 5): Ground. This pin provides a single-point ground for internal references and other critical analog circuits.

V_{RT} (Pin 6): Thermistor Network Termination Output. The LTC4011 provides 3.3V on this pin to drive an external thermistor network connected between V_{RT} , V_{TEMP} and GND. Additional power should not be drawn from this pin by the host application.

V_{TEMP} (Pin 7): Battery Temperature Input. An external thermistor network may be connected to V_{TEMP} to provide temperature-based charge qualification and additional fast charge termination control. Charging may also be paused by connecting the V_{TEMP} pin to GND. Refer to the Operation and Applications Information sections for complete details on external thermistor networks and charge control. If this pin is not used it should be wired to V_{RT} . Operating voltage range is GND to 3.3V.

V_{CELL} (Pin 8): Average Single-Cell Voltage Input. An external voltage divider between BAT and V_{CDIV} is attached to this pin to monitor the average single-cell voltage of the battery pack. The LTC4011 uses this information to protect against catastrophic battery overvoltage and to control the charging state. Refer to the Applications Information section for further details on the external divider network. Operating voltage range is GND to BAT.

PIN FUNCTIONS

V_{CDIV} (Pin 9): Average Cell Voltage Resistor Divider Termination. The LTC4011 connects this pin to GND provided the charger is not in shutdown. V_{CDIV} is an open-drain output to GND with an operating voltage range of GND to BAT.

TIMER (Pin 10): Charge Timer Input. A resistor connected between TIMER and GND programs charge cycle timing limits. Refer to the Applications Information section for complete details. Operating voltage range is GND to 1V.

SENSE (Pin 11): Charge Current Sense Input. An external resistor between this input and BAT is used to program charge current. Refer to the Applications Information section for complete details on programming charge current. Operating voltage ranges from (BAT – 50mV) to (BAT + 200mV).

BAT (Pin 12): Battery Pack Connection. The LTC4011 uses the voltage on this pin to control current sourced from V_{CC} to the battery during charging. Allowable operating voltage range is GND to V_{CC}.

TOC (Pin 13): Active-Low Top-Off Charge Indicator Output. The LTC4011 indicates the top-off charge state for NiMH batteries by connecting this pin to GND. Refer to the Operation and Applications Information sections for further details. This output is capable of driving an LED and should be left floating if not used. $\overline{\text{TOC}}$ is an open-drain output to GND with an operating voltage range of GND to V_{CC}.

INTV_{DD} (Pin 14): Internal 5V Regulator Output. This pin provides a means of bypassing the internal 5V regulator used to power the BGATE output driver. Typically, power should not be drawn from this pin by the application circuit. Refer to the Application Information section for additional details.

BGATE (Pin 15): External Synchronous N-channel MOSFET Gate Control Output. This output provides gate drive to an optional external NMOS power transistor switch used for synchronous rectification to increase efficiency in the step-down DC/DC converter. Operating voltage is GND to INTV_{DD}. BGATE should be left floating if not used.

PGND (Pin 16): Power Ground. This pin provides a return for switching currents generated by internal LTC4011 circuits. Externally, PGND and GND should be wired together using a very low impedance connection. Refer to PCB Layout Considerations in the Applications Information section for additional grounding details.

TGATE (Pin 17): External P-channel MOSFET Gate Control Output. This output provides gate drive to an external PMOS power transistor switch used in the DC/DC converter. Operating voltage range varies as a function of V_{CC}. Refer to the Electrical Characteristics table for specific voltages.

V_{CC} (Pin 18): Power Input. External PowerPath control circuits normally connect either the DC input power supply or the battery to this pin. Refer to the Applications Information section for further details. Suggested applied voltage range is GND to 34V.

READY (Pin 19): Active-Low Ready-to-Charge Output. The LTC4011 connects this pin to GND if proper operating voltages for charging are present. Refer to the Operation section for complete details on charge qualification. This output is capable of driving an LED and should be left floating if not used. $\overline{\text{READY}}$ is an open-drain output to GND with an operating voltage range of GND to V_{CC}.

INFET (Pin 20): PowerPath Control Output. For very low dropout applications, this output may be used to drive the gate of an input PMOS pass transistor connected between the DC input (DCIN) and the raw system supply rail (V_{CC}). INFET is internally clamped about 6V below V_{CC}. Maximum operating voltage is V_{CC}. INFET should be left floating if not used.

Exposed Pad (Pin 21): This pin provides enhanced thermal properties for the TSSOP. It must be soldered to the PCB copper ground to obtain optimum thermal performance.

BLOCK DIAGRAM

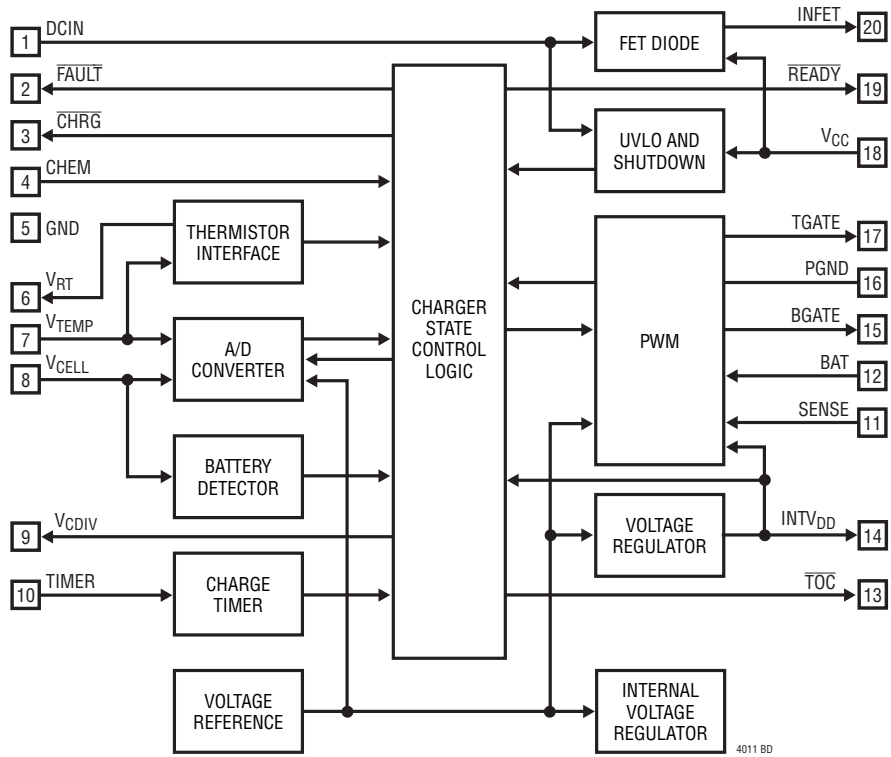

OPERATION

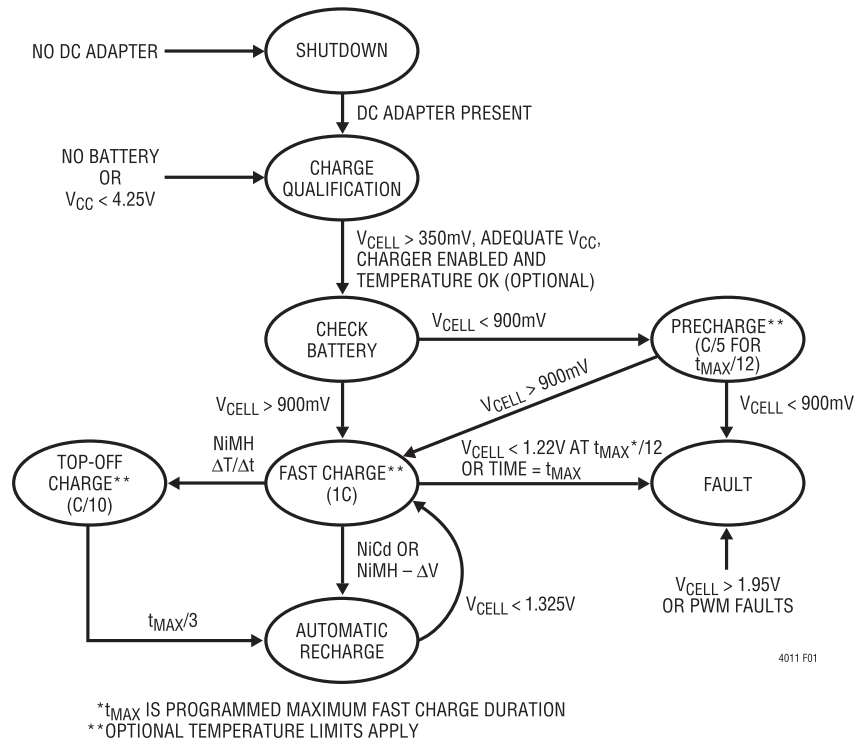

Figure 1. LTC4011 State Diagram

OPERATION (Refer to Figure 1)

Shutdown State

The LTC4011 remains in micropower shutdown until DCIN (Pin 1) is driven above V_{CC} (Pin 18). In shutdown all status and PWM outputs and internally generated terminations or supply voltages are inactive. Current consumption from V_{CC} and BAT is reduced to a very low level.

Charge Qualification State

Once DCIN is greater than V_{CC} , the LTC4011 exits micropower shutdown, enables its own internal supplies, provides V_{RT} voltage for temperature sensing, and switches V_{CDIV} to GND to allow measurement of the average single-cell voltage. The IC also verifies that V_{CC} is at or above 4.2V, V_{CC} is 510mV above BAT and V_{CELL} is between 350mV and 1.95V. If V_{CELL} is below 350mV, no charging will occur, and if V_{CELL} is above 1.95V, the fault state is entered, which is described in more detail below. Once adequate voltage conditions exist for charging, \overline{READY} is asserted.

If the voltage between V_{TEMP} and GND is below 200mV, the LTC4011 is paused. If V_{TEMP} is above 200mV but below 2.85V, the LTC4011 verifies that the sensed temperature is between 5°C and 45°C. If these temperature limits are not met or if its own die temperature is too high, the LTC4011 will indicate a fault and not allow charging to begin. If V_{TEMP} is greater than 2.85V, battery temperature related charge qualification, monitoring and termination are disabled.

Once charging is fully qualified, precharge begins (unless the LTC4011 is paused). In that case, the V_{TEMP} pin is monitored for further control. The charge status indicators and PWM outputs remain inactive until charging begins.

Charge Monitoring

The LTC4011 continues to monitor important voltage and temperature parameters during all charging states. If the DC input is removed, charging stops and the shutdown state is entered. If V_{CC} drops below 4.25V or V_{CELL} drops below 350mV, charging stops and the LTC4011 returns to the charge qualification state. If V_{CELL} exceeds 1.95V, charging stops and the IC enters the fault state. If an external thermistor indicates sensed temperature is beyond a range of 5°C to 60°C, or the internal die temperature exceeds an internal thermal limit, charging is suspended, the charge timer is paused and the LTC4011 indicates a fault condition.

Normal charging resumes from the previous state when the sensed temperature returns to a satisfactory range. In addition, other battery faults are detected during specific charging states as described below.

Precharge State

If the initial voltage on V_{CELL} is below 900mV, the LTC4011 enters the precharge state and enables the PWM current source to trickle charge using one-fifth the programmed charge current. The \overline{CHRG} status output is active during precharge. The precharge state duration is limited to $t_{MAX}/12$ minutes, where t_{MAX} is the maximum fast charge period programmed with the TIMER pin. If sufficient V_{CELL} voltage cannot be developed in this length of time, the fault state is entered, otherwise fast charge begins.

Fast Charge State

If adequate average single-cell voltage exists, the LTC4011 enters the fast charge state and begins charging at the programmed current set by the external current sense resistor connected between the SENSE and BAT pins. The \overline{CHRG} status output is active during fast charge. If V_{CELL} is initially above 1.325V, voltage-based termination processing begins immediately. Otherwise $-\Delta V$ termination is disabled for a stabilization period of $t_{MAX}/12$. In that case, the LTC4011 makes another fault check at $t_{MAX}/12$, requiring the average cell voltage to be above 1.22V. This ensures the battery pack is accepting a fast charge. If V_{CELL} is not above this voltage threshold, the fault state is entered. Fast charge state duration is limited to t_{MAX} and the fault state is entered if this limit is exceeded.

Charge Termination

Fast charge termination parameters are dependent upon the battery chemistry selected with the CHEM pin. Voltage-based termination ($-\Delta V$) is always active after the initial voltage stabilization period. If an external thermistor network is present, chemistry-specific limits for $\Delta T/\Delta t$ (rate of temperature rise) are also used in the termination algorithm. Temperature-based termination, if enabled, becomes active as soon as the fast charge state is entered. Successful charge termination requires a charge rate between C/2 and 2C. Lower rates may not produce the battery voltage and temperature profile required for charge termination.

OPERATION

Top-Off Charge State

If NiMH fast charge termination occurs because the $\Delta T/\Delta t$ limit is exceeded after an initial period of $t_{MAX}/12$ has expired, the LTC4011 enters the top-off charge state. Top-off charge is implemented by sourcing one-tenth the programmed charge current for $t_{MAX}/3$ minutes to ensure that 100% charge has been delivered to the battery. The \overline{CHRG} and \overline{TOC} status outputs are active during the top-off state. If NiCd cells have been selected with the CHEM pin, the LTC4011 never enters the top-off state.

Automatic Recharge State

Once charging is complete, the automatic recharge state is entered to address the self-discharge characteristics of nickel chemistry cells. The charge status outputs are inactive during automatic recharge, but V_{CDIV} remains switched to GND to monitor the average cell voltage. If the V_{CELL} voltage drops below 1.325V without falling below 350mV, the charge timer is reset and a new fast charge cycle is initiated.

The internal termination algorithms of the LTC4011 are adjusted when a fast charge cycle is initiated from automatic recharge, because the battery should be almost fully charged. Voltage-based termination is enabled immediately and the NiMH $\Delta T/\Delta t$ limit is fixed at a battery temperature rise of 1°C/minute.

Fault State

As discussed previously, the LTC4011 enters the fault state based on detection of invalid battery voltages during various charging phases. The IC also monitors the regulation of the PWM control loop and will enter the fault state if this is not within acceptable limits. Once in the fault state, the battery must be removed or DC input power must be cycled in order to initiate further charging. In the fault state, the \overline{FAULT} output is active, the \overline{READY} output is inactive, charging stops and the charge indicator outputs are inactive. The V_{CDIV} output remains connected to GND to allow detection of battery removal.

Note that the LTC4011 also uses the \overline{FAULT} output to indicate that charging is suspended due to invalid battery or internal die temperatures. However, the IC does not enter the fault state in these cases and normal operation will

resume when all temperatures return to acceptable levels. Refer to the Status Outputs section for more detail.

Insertion and Removal of Batteries

The LTC4011 automatically senses the insertion or removal of a battery by monitoring the V_{CELL} pin voltage. Should this voltage fall below 350mV, the IC considers the battery to be absent. Removing and then inserting a battery causes the LTC4011 to initiate a completely new charge cycle beginning with charge qualification.

External Pause Control

After charging is initiated, the V_{TEMP} pin may be used to pause operation at any time. When the voltage between V_{TEMP} and GND drops below 200mV, the charge timer pauses, fast charge termination algorithms are inhibited and the PWM outputs are disabled. The status and V_{CDIV} outputs all remain active. Normal function is fully restored from the previous state when pause ends.

Status Outputs

The LTC4011 open-drain status outputs provide valuable information about the IC's operating state and can be used for a variety of purposes in applications. Table 1 summarizes the state of the four status outputs and the V_{CDIV} pin as a function of LTC4011 operation. The status outputs can directly drive current-limited LEDs terminated to the DC input. The V_{CDIV} column in Table 1 is strictly informational. V_{CDIV} should only be used for the V_{CELL} resistor divider, as previously discussed.

Table 1. LTC4011 Status Pins

READY	FAULT	CHRG	TOC	V_{CDIV}	CHARGER STATE
Off	Off	Off	Off	Off	Off
On	Off	Off	Off	On	Ready to Charge (V_{TEMP} Held Low) or Automatic Recharge
On	Off	On	Off	On	Precharge or Fast Charge (May be Paused)
On	Off	On	On	On	NiMH Top-Off Charge (May be Paused)
On	On	On or Off	On or Off	On	Temperature Limits Exceeded
Off	On	Off	Off	On	Fault State (Latched)

OPERATION

PWM Current Source Controller

An integral part of the LTC4011 is the PWM current source controller. The charger uses a synchronous step-down architecture to produce high efficiency and limited thermal dissipation. The nominal operating frequency of 550kHz allows use of a smaller external filter components. The TGATE and BGATE outputs have internally clamped voltage swings. They source peak currents tailored to smaller surface-mount power FETs likely to appear in applications providing an average charge current of 3A or less. During the various charging states, the LTC4011 uses the PWM controller to regulate an average voltage between SENSE and BAT that ranges from 10mV to 100mV.

A conceptual diagram of the LTC4011 PWM control loop is shown in Figure 2.

The voltage across the external current programming resistor R_{SENSE} is averaged by integrating error amplifier EA. An internal programming current is also pulled from input resistor R1. The $I_{PROG} \cdot R1$ product establishes the desired average voltage drop across R_{SENSE} , and hence, the average current through R_{SENSE} . The I_{TH} output of the error amplifier is a scaled control current for the input

of the PWM comparator CC. The $I_{TH} \cdot R3$ product sets a peak current threshold for CC such that the desired average current through R_{SENSE} is maintained. The current comparator output does this by switching the state of the SR latch at the appropriate time.

At the beginning of each oscillator cycle, the PWM clock sets the SR latch and the external P-channel MOSFET is switched on (N-channel MOSFET switched off) to refresh the current carried by the external inductor. The inductor current and voltage drop across R_{SENSE} begin to rise linearly. During normal operation, the PFET is turned off (NFET on) during the cycle by CC when the voltage difference across R_{SENSE} reaches the peak value set by the output of EA. The inductor current then ramps down linearly until the next rising PWM clock edge. This closes the loop and maintains the desired average charge current in the external inductor.

Low Dropout Charging

After charging is initiated, the LTC4011 does not require that V_{CC} remain at least 500mV above BAT because situations exist where low dropout charging might occur. In one instance, parasitic series resistance may limit PWM headroom (between V_{CC} and BAT) as 100% charge is reached. A second case can arise when the DC adapter selected by the end user is not capable of delivering the current programmed by R_{SENSE} , causing the output voltage of the adapter to collapse. While in low dropout, the LTC4011 PWM runs near 100% duty cycle with a frequency that may not be constant and can be less than 550kHz. The charge current will drop below the programmed value to avoid generating audible noise, so the actual charge delivered to the battery may depend primarily on the LTC4011 charge timer.

Internal Die Temperature

The LTC4011 provides internal overtemperature detection to protect against electrical overstress, primarily at the FET driver outputs. If the die temperature rises above this thermal limit, the LTC4011 stops switching and indicates a fault as previously discussed.

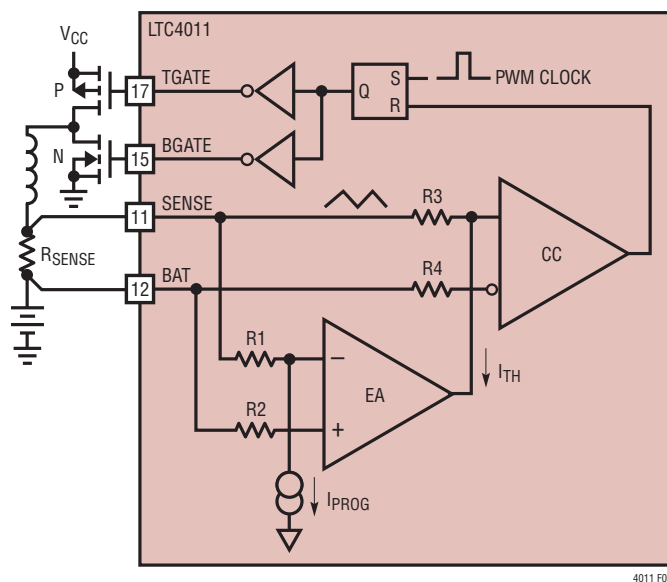

Figure 2. LTC4011 PWM Control Loop

APPLICATIONS INFORMATION

External DC Source

The external DC power source should be connected to the charging system and the V_{CC} pin through either a power diode or P-channel MOSFET. This prevents catastrophic system damage in the event of an input short to ground or reverse-voltage polarity at the DC input. The LTC4011 automatically senses when this input is present. The open-circuit voltage of the DC source should be between 4.5V and 34V, depending on the number of cells being charged. In order to avoid low dropout operation, ensure 100% capacity at charge termination, and allow reliable detection of battery insertion, removal or overvoltage, the following equation can be used to determine the minimum full-load voltage that should be provided by the external DC power source.

$$DCIN(MIN) = (n \cdot 2V) + 0.3V$$

where n is the number of series cells in the battery pack.

The LTC4011 will properly charge over a wide range of DCIN and BAT voltage combinations. Operating the LTC4011 in low dropout or with DCIN much greater than BAT will force the PWM frequency to be much less than 550kHz. The LTC4011 disables charging and sets a fault if a large DCIN to BAT differential would cause generation of audible noise.

PowerPath Control

Proper PowerPath control is an important consideration when fast charging nickel cells. This control ensures that the system load remains powered at all times, but that normal system operation and associated load transients do not adversely affect fast charge termination. For high efficiency and low dropout applications, the LTC4011 can provide gate drive from the INFET pin directly to an input P-channel MOSFET.

The battery should also be connected to the raw system supply by a switch that selects the battery for system power only if an external DC source is not present. Again, for applications requiring higher efficiency, a P-channel MOSFET with its gate driven from the DC input can be used to perform this switching function (see Figure 8). Gate voltage clamping may be necessary on an external PMOS transistor used in this manner at higher input voltages. Alternatively, a diode can be used in place of this FET.

Battery Chemistry Selection

The desired battery chemistry is selected by programming the CHEM pin to the proper voltage. If it is wired to GND, a set of parameters specific to charging NiMH cells is selected. When CHEM is left floating or connected to V_{RT} , charging is optimized for NiCd cells. The various charging parameters are detailed in Table 2.

Programming Charge Current

Charge current is programmed using the following equation:

$$R_{SENSE} = \frac{100mV}{I_{PROG}}$$

R_{SENSE} is an external resistor connected between the SENSE and BAT pins. A 1% resistor with a low temperature coefficient and sufficient power dissipation capability to avoid self-heating effects is recommended. Charge rate should be between approximately C/2 and 2C.

Inductor Value Selection

For many applications, 10 μ H represents an optimum value for the inductor the PWM uses to generate charge current. For applications with I_{PROG} of 1.5A or greater running from an external DC source of 15V or less, values between 5 μ H and 7.5 μ H can often be selected. For wider operating conditions the following equation can be used as a guide for selecting the minimum inductor value.

$$L > 6.5 \cdot 10^{-6} \cdot V_{DCIN} \cdot R_{SENSE}, L \geq 4.7\mu H$$

Actual part selection should account for both manufacturing tolerance and temperature coefficient to ensure this minimum. A good initial selection can be made by multiplying the calculated minimum by 1.4 and rounding up or down to the nearest standard inductance value.

Ultimately, there is no substitute for bench evaluation of the selected inductor in the target application, which can also be affected by other environmental factors such as ambient operating temperature. Using inductor values lower than recommended by the equation shown above can result in a fault condition at the start of precharge or top-off charge.

APPLICATIONS INFORMATION

Table 2. LTC4011 Charging Parameters

STATE	CHEM PIN	BAT CHEMISTRY	TIMER	T _{MIN}	T _{MAX}	I _{CHRG}	TERMINATION CONDITION
PC		Both	t _{MAX} /12	5°C	45°C	I _{PROG} /5	Timer Expires
FC	Open	NiCd	t _{MAX}	5°C	60°C	I _{PROG}	-20mV per Cell or 2°C/Minute
	GND	NiMH	t _{MAX}	5°C	60°C	I _{PROG}	1.5°C/Minute for First t _{MAX} /12 Minutes if Initial V _{CELL} < 1.325V -10mV per Cell or 1°C/Minute After t _{MAX} /12 Minutes or if Initial V _{CELL} > 1.325V
TOC	GND	NiMH	t _{MAX} /3	5°C	60°C	I _{PROG} /10	Timer Expires
AR		Both		5°C	45°C	0	V _{CELL} < 1.325V

PC: Precharge

FC: Fast Charge (Initial -ΔV Termination Hold Off of t_{MAX}/12 Minutes May Apply)

TOC: Top-Off Charge (Only for NiMH ΔT/Δt FC Termination After Initial t_{MAX}/12 Period)

AR: Automatic Recharge (Temperature Limits Apply to State Termination Only)

Table 3. LTC4011 Time Limit Programming Examples

R _{TIMER}	TYPICAL FAST CHARGE RATE	PRECHARGE LIMIT (MINUTES)	FAST CHARGE VOLTAGE STABILIZATION (MINUTES)	FAST CHARGE LIMIT (HOURS)	TOP-OFF CHARGE (MINUTES)
24.9k	2C	3.8	3.8	0.75	15
33.2k	1.5C	5	5	1	20
49.9k	1C	7.5	7.5	1.5	30
66.5k	0.75C	10	10	2	40
100k	C/2	15	15	3	60

Programming Maximum Charge Times

Connecting the appropriate resistor between the TIMER pin and GND programs the maximum duration of various charging states. To some degree, the value should reflect how closely the programmed charge current matches the 1C rate of targeted battery packs. The maximum fast charge period is determined by the following equation:

$$R_{\text{TIMER}} = \frac{t_{\text{MAX}} (\text{Hours})}{30 \cdot 10^{-6}} (\Omega)$$

Some typical timing values are detailed in Table 3. R_{TIMER} should not be less than 15k. The actual time limits used by the LTC4011 have a resolution of approximately ±30 seconds in addition to the tolerances given the Electrical Characteristics table. If the timer ends without a valid -ΔV or ΔT/Δt charge termination, the charger enters the fault state. The maximum time period is approximately 4.3 hours.

Cell Voltage Network Design

An external resistor network is required to provide the average single-cell voltage to the V_{CELL} pin of the LTC4011.

The proper circuit for multicell packs is shown in Figure 3. The ratio of R2 to R1 should be a factor of (n - 1), where n is the number of series cells in the battery pack. The value of R1 should be between 1k and 100k. This range limits the sensing error caused by V_{CELL} leakage current and prevents the ON resistance of the internal NFET between V_{CDIV} and GND from causing a significant error in the V_{CELL} voltage. The external resistor network is also used to detect battery insertion and removal. The filter formed by C1 and the parallel combination of R1 and R2

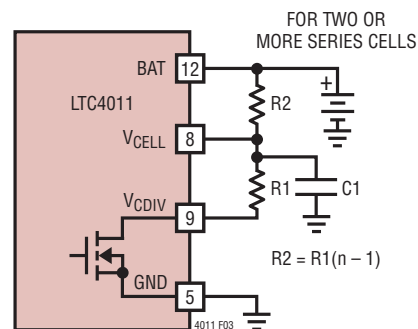

Figure 3. Multiple Cell Voltage Divider

4011fb

APPLICATIONS INFORMATION

is recommended for rejecting PWM switching noise. The value of C1 should be chosen to yield a 1st order lowpass frequency of less than 500Hz. In the case of a single cell, the external application circuit shown in Figure 4 is recommended to provide the necessary noise filtering and missing battery detection.

Thermistor Network Design

The network for proper temperature sensing using a thermistor with a negative temperature coefficient (NTC) is shown in Figure 5. R3 is only present for thermistors with an exponential temperature coefficient (β) above 3750. For thermistors with β below 3750, replace R3 with a short.

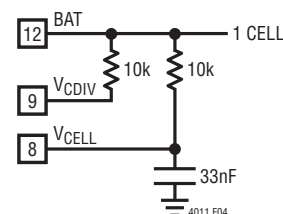

Figure 4. Single-Cell Monitor Network

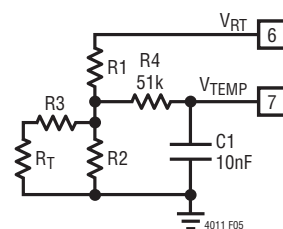

Figure 5. External NTC Thermistor Network

The LTC4011 is designed to work best with a 5% 10K NTC thermistor with a β near 3750, such as the Siemens/EPCOS B57620C103J062. In this case, the values for the external network are given by:

$$\begin{aligned} R1 &= 9.76k \\ R2 &= 28k \\ R3 &= 0\Omega \end{aligned}$$

However, the LTC4011 will operate with other NTC thermistors having different nominal values or exponential temperature coefficients. For these thermistors, the design equations for the resistors in the external network are:

$$R1 = \frac{\beta R_0 T_0^2}{\left(2.461\beta + 4.921T_0 + \frac{T_0^2}{11.46}\right)^2}$$

$$R2 = \frac{(R_0 + R3)(\beta(R_0 - R3) - 2(R_0 + R3)T_0)}{\beta\left(\frac{R_0}{7.1} + R3\right) + 2(R_0 + R3)T_0}$$

$$R3 = \frac{R_0\left(\beta - 2T_0 - \frac{T_0^2}{28.2}\right)}{\beta + 2T_0 + \frac{T_0^2}{28.2}}$$

where:

R_0 = thermistor resistance (Ω) at T_0

T_0 = thermistor reference temperature ($^{\circ}\text{K}$)

β = exponential temperature coefficient of resistance

For thermistors with β less than 3750, the equation for R3 yields a negative number. This number should be used to compute R2, even though R3 is replaced with a short in the actual application. An additional high temperature charge qualification error of between 0°C and 5°C may occur when using thermistors with β lower than 3750. Thermistors with nominal β less than 3300 should be avoided.

The filter formed by R4 and C1 in Figure 5 is optional but recommended for rejecting PWM switching noise. Alternatively, R4 may be replaced by a short, and a value chosen for C1 which will provide adequate filtering from the Thevenin impedance of the remaining thermistor network. The filter pole frequency, which should be less than 500Hz, will vary more with battery temperature without R4. External components should be chosen to make the Thevenin impedance from V_{TEMP} to GND 100k Ω or less, including R4, if present.

Disabling Thermistor Functions

Temperature sensing is optional in LTC4011 applications. For low cost systems where temperature sensing may not be required, the V_{TEMP} pin may simply be wired to V_{RT} to disable temperature qualification of all charging

4011fb

APPLICATIONS INFORMATION

operations. However, this practice is not recommended for NiMH cells charged well above or below their 1C rate, because fast charge termination based solely on voltage inflection may not be adequate to protect the battery from a severe overcharge. A resistor between 10k and 20k may be used to connect V_{TEMP} to V_{RT} if the pause function is still desired.

INTV_{DD} Regulator Output

If BGATE is left open, the INTV_{DD} pin of the LTC4011 can be used as an additional source of regulated voltage in the host system any time READY is active. Switching loads on INTV_{DD} may reduce the accuracy of internal analog circuits used to monitor and terminate fast charging. In addition, DC current drawn from the INTV_{DD} pin can greatly increase internal power dissipation at elevated V_{CC} voltages. A minimum ceramic bypass capacitor of 0.1 μ F is recommended.

Calculating Average Power Dissipation

The user should ensure that the maximum rated IC junction temperature is not exceeded under all operating conditions. The thermal resistance of the LTC4011 package (θ_{JA}) is 38°C/W, provided the exposed metal pad is properly soldered to the PCB. The actual thermal resistance in the application will depend on the amount of PCB copper to which the package is soldered. Feedthrough vias directly below the package that connect to inner copper layers are helpful in lowering thermal resistance. The following formula may be used to estimate the maximum average power dissipation P_D (in watts) of the LTC4011 under normal operating conditions.

$$P_D = V_{CC}(9mA + I_{DD} + I_{VRT} + 615k(Q_{TGATE} + Q_{BGATE})) \\ - 3I_{VRT} - 3.85I_{DD} + 60n \left(\frac{V_{CC} - V_{LED}}{R_{LED} + 30} \right)^2$$

where:

I_{DD} = Average external INTV_{DD} load current, if any

I_{VRT} = Load current drawn by the external thermistor network from V_{RT} , if any

Q_{TGATE} = Gate charge of external P-channel MOSFET in coulombs

Q_{BGATE} = Gate charge of external N-channel MOSFET (if used) in coulombs

V_{LED} = Maximum external LED forward voltage

R_{LED} = External LED current-limiting resistor used in the application

n = Number of LEDs driven by the LTC4011

Sample Applications

Figures 6 through 9 detail sample charger applications of various complexities. Combined with the Typical Application on the first page of this data sheet, these Figures demonstrate some of the proper configurations of the LTC4011. MOSFET body diodes are shown in these figures strictly for reference only.

Figure 6 shows a minimum application, which might be encountered in low cost NiCd fast charge applications. FET-based PowerPath control allows for maximum input voltage range from the DC adapter. The LTC4011 uses $-\Delta V$ to terminate the fast charge state, as no external temperature information is available. Nonsynchronous PWM switching is employed to reduce external component cost. A single LED indicates charging status.

A 3A NiMH application of medium complexity is shown in Figure 7. PowerPath control that is completely FET-based allows for both minimum input voltage overhead and minimum switchover loss when operating from the battery.

P-channel MOSFET Q4 functions as a switch to connect the battery to the system load whenever the DC input adapter is removed. If the maximum battery voltage is less than the maximum rated V_{GS} of Q4, diode D1 and resistor R5 are not required. Otherwise choose the Zener voltage of D1 to be less than the maximum rated V_{GS} of Q4. R5 provides a bias current of $(V_{BAT} - V_{ZENER})/(R5 + 20k)$ for D1 when the input adapter is removed. Choose R5 to make this current, which is drawn from the battery, just large enough to develop the desired V_{GS} across D1.

Precharge, fast charge and top-off states are indicated by external LEDs. The V_{TEMP} thermistor network allows the LTC4011 to accurately terminate fast charge under a variety of applied charge rates. Use of a synchronous PWM topology improves efficiency and lowers power dissipation.

APPLICATIONS INFORMATION

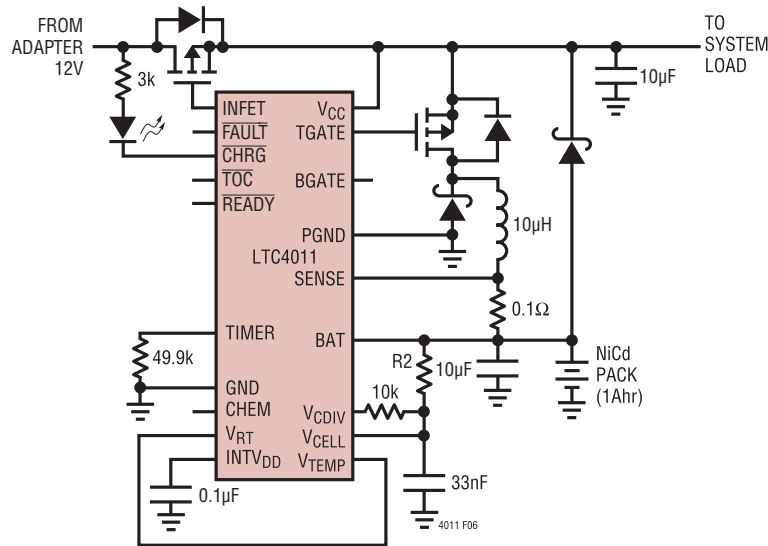

Figure 6. Minimum 1A LTC4011 Application

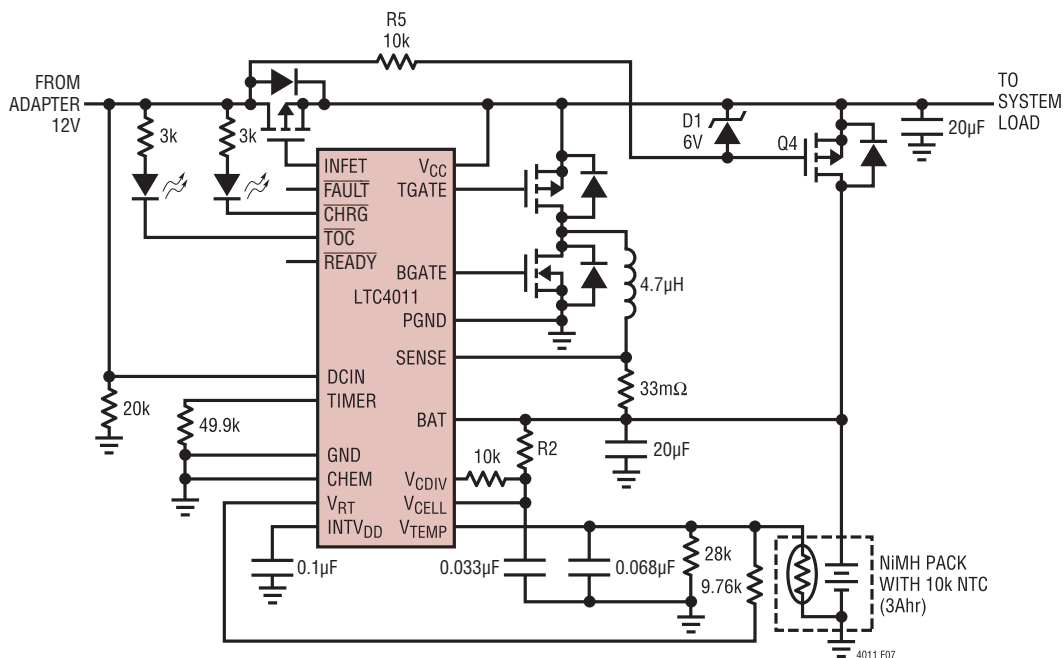

Figure 7. 3A NiMH Charger with Full PowerPath Control

A full-featured 2A LTC4011 application is shown in Figure 8. FET-based PowerPath allows for maximum input voltage range from the DC adapter. The inherent voltage ratings of the V_{CELL} , V_{CDIV} , SENSE and BAT pins allow charging of one to sixteen series nickel cells in this application, governed only by the V_{CC} overhead limits previously discussed. The application includes all average cell voltage

and battery temperature sensing circuitry required for the LTC4011 to utilize its full range of charge qualification, safety monitoring and fast charge termination features. LED D1 indicates valid DC input voltage and installed battery, while LEDs D2 and D3 indicate charging. LED D4 indicates fault conditions. The grounded CHEM pin selects the NiMH charge termination parameter set.

APPLICATIONS INFORMATION

Unlike all of the other applications discussed so far, the battery continues to power the system during charging. The MCU could be powered directly from the battery or from any type of post regulator operating from the battery. In this configuration, the LTC4011 relies expressly on the ability of the host MCU to know when load transients will be encountered. The MCU should then pause charging (and thus $-\Delta V$ processing) during those events to avoid premature fast charge termination. If the MPU cannot reliably perform this function, full PowerPath control *should* be implemented. In most applications, there should not be an external load on the battery during charge. Excessive battery load current variations, such as those generated by a post-regulating PWM, can generate sufficient voltage noise to cause the LTC4011 to prematurely terminate a charge cycle and/or prematurely restart a fast charge. In this case, it may be necessary to inhibit the LTC4011 after charging is complete until external gas gauge circuitry indicates that recharging is necessary. Shutdown power is applied to the LTC4011 through the body diode of Q2 in this application.

Waveforms

Sample waveforms for a standalone application during a typical charge cycle are shown in Figure 10. Note that these waveforms are not to scale and do not represent the complete range of possible activity. The figure is simply intended to allow better conceptual understanding and to highlight the relative behavior of certain signals generated by the LTC4011 during a typical charge cycle.

Initially, the LTC4011 is in low power shutdown as the system operates from a heavily discharged battery. A DC adapter is then connected such that V_{CC} rises above 4.25V and is 500mV above BAT. The $\overline{\text{READY}}$ output is asserted when the LTC4011 completes charge qualification.

When the LTC4011 determines charging should begin, it starts a precharge cycle because V_{CELL} is less than 900mV. As long as the temperature remains within prescribed limits, the LTC4011 charges (TGATE switching), applying limited current to the battery with the PWM in order to bring the average cell voltage to 900mV.

When the precharge state timer expires, the LTC4011 begins fast charge if V_{CELL} is greater than 900mV. The

PWM, charge timer and internal termination control are suspended if pause is asserted ($V_{\text{TEMP}} < 200\text{mV}$), but all status outputs continue to indicate charging is in progress. The fast charge state continues until the selected voltage or temperature termination criteria are met. Figure 10 suggests termination based on $\Delta T/\Delta t$, which for NiMH would be an increase greater than 1°C per minute.

Because NiMH charging terminated due to $\Delta T/\Delta t$ and the fast charge cycle had lasted more than $t_{\text{MAX}}/12$ minutes, the LTC4011 begins a top-off charge with a current of $I_{\text{PROG}}/10$. Top-off is an internally timed charge of $t_{\text{MAX}}/3$ minutes with the $\overline{\text{CHRG}}$ and $\overline{\text{TOC}}$ outputs continuously asserted.

Finally, the LTC4011 enters the automatic recharge state where the $\overline{\text{CHRG}}$ and $\overline{\text{TOC}}$ outputs are deasserted. The PWM is disabled but V_{CDIV} remains asserted to monitor V_{CELL} . The charge timer will be reset and fast charging will resume if V_{CELL} drops below 1.325V. The LTC4011 enters shutdown when the DC adapter is removed, minimizing current draw from the battery in the absence of an input power source.

While not a part of the sample waveforms of Figure 10, temperature qualification is an ongoing part of the charging process, if an external thermistor network is detected by the LTC4011. Should prescribed temperature limits be exceeded during any particular charging state, charging would be suspended until the sensed temperature returned to an acceptable range.

Battery-Controlled Charging

Because of the programming arrangement of the LTC4011, it may be possible to configure it for battery-controlled charging. In this case, the battery pack is designed to provide customized information to an LTC4011-based charger, allowing a single design to service a wide range of application batteries. Assume the charger is designed to provide a maximum charge current of 800mA ($R_{\text{SENSE}} = 125\text{m}\Omega$). Figure 11 shows a 4-cell NiCd battery pack for which 800mA represents a 0.75C rate. When connected to the charger, this pack would provide battery temperature information and correctly configure both fast charge termination parameters and time limits for the internal NiCd cells.

APPLICATIONS INFORMATION

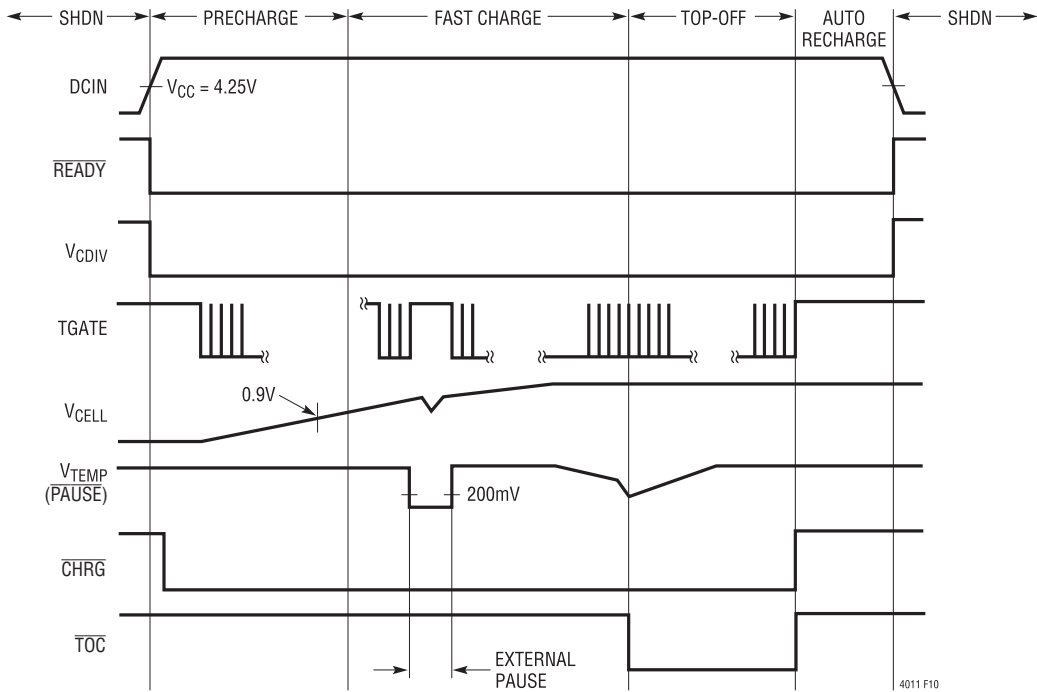

Figure 10. Charging Waveforms Example

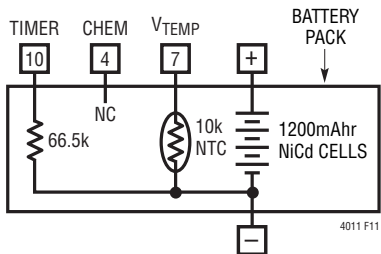

Figure 11. NiCd Battery Pack with Time Limit Control

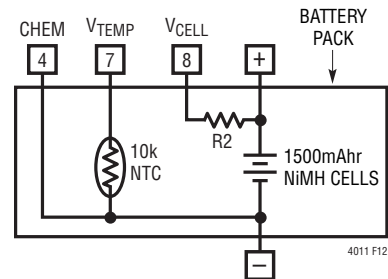

Figure 12. NiMH Battery Pack Indicating Number of Cells

A second possibility is to configure an LTC4011-based charger to accept battery packs with varying numbers of cells. By including R2 of the average cell voltage divider network shown in Figure 3, battery-based programming of the number of series-stacked cells could be realized without defeating LTC4011 detection of battery insertion or removal. Figure 12 shows a 2-cell NiMH battery pack that programs the correct number of series cells when it is connected to the charger, along with indicating chemistry and providing temperature information.

Any of these battery pack charge control concepts could be combined in a variety of ways to service custom application needs. Charging parallel cells is not recommended.

PCB Layout Considerations

To prevent magnetic and electrical field radiation and high frequency resonant problems, proper layout of the components connected to the LTC4011 is essential. Refer to Figure 13. For maximum efficiency, the switch node rise and fall times should be minimized. The following PCB design priority list will help ensure proper topology. Layout the PCB using this specific order.

1. Input capacitors should be placed as close as possible to switching FET supply and ground connections with the shortest copper traces possible. The switching FETs must be on the same layer of copper as the input

APPLICATIONS INFORMATION

- capacitors. Vias should not be used to make these connections.
- Place the LTC4011 close to the switching FET gate terminals, keeping the connecting traces short to produce clean drive signals. This rule also applies to IC supply and ground pins that connect to the switching FET source pins. The IC can be placed on the opposite side of the PCB from the switching FETs.
 - Place the inductor input as close as possible to the drain of the switching FETs. Minimize the surface area of the switch node. Make the trace width the minimum needed to support the programmed charge current. Use no copper fills or pours. Avoid running the connection on multiple copper layers in parallel. Minimize capacitance from the switch node to any other trace or plane.
 - Place the charge current sense resistor immediately adjacent to the inductor output, and orient it such that current sense traces to the LTC4011 are short. These feedback traces need to be run together as a single pair with the smallest spacing possible on any given layer on which they are routed. Locate any filter component on these traces next to the LTC4011, and not at the sense resistor location.
 - Place output capacitors adjacent to the sense resistor output and ground.
 - Output capacitor ground connections must feed into the same copper that connects to the input capacitor ground before tying back into system ground.
 - Connection of switching ground to system ground, or any internal ground plane should be single-point. If the system has an internal system ground plane, a good way to do this is to cluster vias into a single star point to make the connection.
 - Route analog ground as a trace tied back to the LTC4011 GND pin before connecting to any other ground. Avoid using the system ground plane. A useful CAD technique is to make analog ground a separate ground net and use a 0Ω resistor to connect analog ground to system ground.
 - A good rule of thumb for via count in a given high current path is to use 0.5A per via. Be consistent when applying this rule.
 - If possible, place all the parts listed above on the same PCB layer.
 - Copper fills or pours are good for all power connections except as noted above in Rule 3. Copper planes on multiple layers can also be used in parallel. This helps with thermal management and lowers trace inductance, which further improves EMI performance.
 - For best current programming accuracy, provide a Kelvin connection from R_{SENSE} to SENSE and BAT. See Figure 14 for an example.
 - It is important to minimize parasitic capacitance on the TIMER, SENSE and BAT pins. The traces connecting these pins to their respective resistors should be as short as possible.

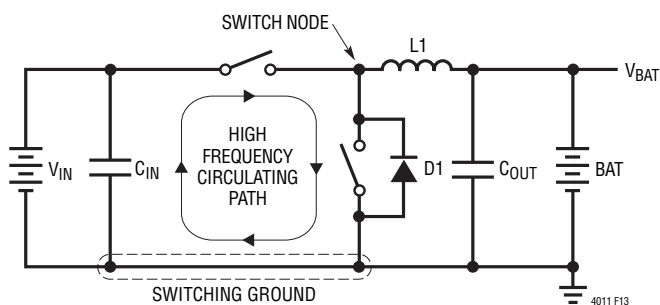

Figure 13. High Speed Switching Path

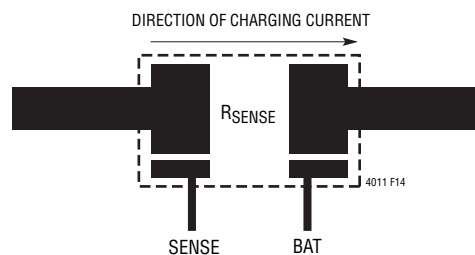

Figure 14. Kelvin Sensing of Charge Current

REVISION HISTORY (Revision history begins at Rev B)

REV	DATE	DESCRIPTION	PAGE NUMBER
B	01/10	Changes to Typical Application	1
		Updated Order Information Section	2
		Changes to Electrical Characteristics	2, 3, 4
		Changes to Operation Section	12, 13, 14
		Changes to Applications Information	15, 16, 19, 21, 22
		Changes to Figures 6, 7, 8, 9	19, 20

RELATED PARTS

PART NUMBER	DESCRIPTION	COMMENTS
LT [®] 1510	Constant-Voltage/Constant-Current Battery Charger	Up to 1.5A Charge Current for Li-Ion, NiCd and NiMH Batteries
LT1511	3A Constant-Voltage/Constant-Current Battery Charger	High Efficiency, Minimum External Components to Fast Charge Lithium, NiMH and NiCd Batteries
LT1513	SEPIC Constant- or Programmable-Current/Constant-Voltage Battery Charger	Charger Input Voltage May be Higher, Equal to or Lower than Battery Voltage, 500kHz Switching Frequency
LTC1760	Smart Battery System Manager	Autonomous Power Management and Battery Charging for Two Smart Batteries, SMBus Rev 1.1 Compliant
LTC1960	Dual Battery Charger/Selector with SPI	11-Bit V-DAC, 0.8% Voltage Accuracy, 10-Bit I-DAC, 5% Current Accuracy
LTC4008	High Efficiency, Programmable Voltage/Current Battery Charger	Constant-Current/Constant-Voltage Switching Regulator, Resistor Voltage/Current Programming, AC Adapter Current Limit and Thermistor Sensor and Indicator Outputs
LTC4010	High Efficiency Standalone Nickel Battery Charger	Complete NiMH/NiCd Charger in a Small 16-Pin Package, Constant-Current Switching Regulator
LTC4060	Standalone Linear NiMH/NiCd Fast Charger	Complete NiMH/NiCd Charger in a Small Leaded or Leadless 16-Pin Package, No Sense Resistor or Blocking Diode Required
LTC4100	Smart Battery Charger Controller	Level 2 Charger Operates with or without MCU Host, SMBus Rev. 1.1 Compliant
LTC4150	Coulomb Counter/Battery Gas Gauge	High Side Sense of Charge Quantity and Polarity in a 10-Pin MSOP
LTC4411	2.6A Low Loss Ideal Diode	No External MOSFET, Automatic Switching Between DC Sources, Simplified, 140mΩ On Resistance, ThinSOT™ Package
LTC4412/ LTC4412HV	Low Loss PowerPath Controllers	Very Low Loss Replacement for Power Supply ORing Diodes Using Minimal External Components, $3V \leq V_{IN} \leq 28V$, ($3V \leq V_{IN} \leq 36V$ for HV)
LTC4413	Dual 2.6A, 2.5V to 5.5V, Ideal Diodes	Low Loss Replacement for ORing Diodes, 100mΩ On Resistance

ThinSOT is a trademark of Linear Technology Corporation.