

# TDK-Lambda PFE-SA, PFE500-F & PFE1000-FA

## 300-1008W AC-DC Power Module

### Features

- ◆ Low profile, small size
- ◆ 100°C baseplate temperature
- ◆ High power density
- ◆ High Efficiency
- ◆ Suitable for conduction cooling
- ◆ Power Factor Corrected (PFC)



### Key Market Segments & Applications



### Specifications

Model		PFE300SA PFE500SA	PFE700SA	PFE500F	PFE1000FA
AC Input	VAC	85 to 265VAC, 47-63Hz (up to 440Hz) (4)			
Input Current (115 / 230VAC)	A	3.2 / 1.6	7.0 / 3.4	6.8 / 3.4	10.8 / 5.3
Model dependant	A	5.2 / 2.5	7.0 / 3.4	100/200VAC	10.8 / 5.3
Inrush Current (115 / 230VAC) (1)	A	23 / 46A peak			
Power Factor	-	0.95 minimum, meets EN61000-3-2			
Output Voltage Setpoint Accuracy	-	±2%	±1V	±2%	±2%
Ripple and Noise (1)	-	1%	4V	1%	1%
Over Current Protection	%	105 - 140% (Automatic Recovery)			105 - 140% Manual reset
Over Voltage Protection	-	125 - 145%	60 - 69.6V	125 - 145%	125 - 145%
Series Operation	-	Yes			
Parallel Operation	-	No	Yes (Droop mode)	Yes (Single wire)	Yes (Single wire)
Power On Signal (ENA)	-	Open collector (10mA sink current). Low (on) when output is present			
Auxiliary Supply	-	None	None	10 - 14V, 20mA	10 - 14V, 20mA
Remote On/Off (Opto isolated)	-	None	None	High = On	High = On
Overtemperature Protection	-	Yes			
Operating Baseplate Temp.	°C	-40 to +100°C (2)			
Storage Temperature	°C	-40 to +100°C			
Humidity (non condensing)	-	Operating: 20 - 95%RH, Non Operating: 10 - 95%RH			
Cooling	-	Conduction			
Withstand Voltage (1 min) (3)	-	Input to Output 3kVAC, Input to Baseplate 2.5kVAC, Output to Baseplate 1.5kVDC			
Isolation Resistance	-	Output to baseplate: 100M Ohm at 500VDC, 25°C ambient, 70%RH			
Vibration (non operating)	-	10-55Hz (1 min sweep), constant amplitude 0.825mm (max 49m/s <sup>2</sup> ), X, Y, Z 1 hour each			
Shock	-	196.1m/s <sup>2</sup>			
Safety Certifications	-	IEC/UL/CSA/EN62368-1, 60950-1, CE Mark			
Weight	g	200		300	420
Size (WxHxL)	mm	61 x 12.7 x 116.8mm		70 x 12.7 x 122mm	100 x 13.4 x 160mm
	in	2.4 x 0.5 x 4.6"		2.76 x 0.5 x 4.8"	3.94 x 0.53 x 6.3"
Warranty	yrs	5 years		2 years	5 years

Notes: (Consult Installation Manual for detailed specifications, test methods and application notes)

- 1) External components are required, consult Application Notes
- 2) PFE500SA-12, PFE500F-12: -40 to 85°C. See instruction manuals for derating curves  
PFE1000FA, PFE1000F48 & PFE1000FA48: -40 to 85°C below 170VAC input voltage.  
See instruction manuals for derating curves
- 3) PFE500F, PFE1000FA: 500VDC Output to baseplate
- 4) Reduced PFC above 63Hz. Contact technical support for 440Hz operation.

# TDK-Lambda PFE-SA, PFE500-F & PFE1000-FA

## Specifications

Model	Output Voltage (V)	Adjust. Range (V)	Maximum Current (A)	Maximum Wattage (W)	Load Reg. (mV)	Line Reg. (mV)	Efficiency typ (5)
PFE300SA-12	12	9.6 - 14.4	25	300	48	48	84 / 86
PFE500SA-12	12	9.6 - 14.4	33	396	48	48	84 / 86
PFE500F-12	12	9.6 - 14.4	42	504	48	48	81 / 83
PFE1000FA-12	12	9.6 - 14.4	60	720	48	48	84.5 / 87
PFE300SA-28	28	22.4 - 33.6	10.8	302	56	56	87.5 / 89.5
PFE500SA-28	28	22.4 - 33.6	18	504	56	56	88 / 90
PFE500F-28	28	22.4 - 33.6	18	504	56	56	84 / 86
PFE1000FA-28	28	22.4 - 33.6	36	1008	56	56	87 / 89.5
PFE300SA-48	48	38.4 - 57.6	6.3	302	96	96	88 / 90.5
PFE500SA-48	48	38.4 - 57.6	10.5	504	96	96	90 / 91
PFE500F-48	48	38.4 - 57.6	10.5	504	96	96	84 / 86
PFE1000FA-48	48	38.4 - 57.6	21	1008	96	96	88 / 90.5
PFE700SA-48	51	None	14	714	50 - 57V (6)		90 / 92

(5) 115 / 230VAC (100/230VAC for PFE500F)

(6) Total regulation range

## PFE500SA Outline Drawing

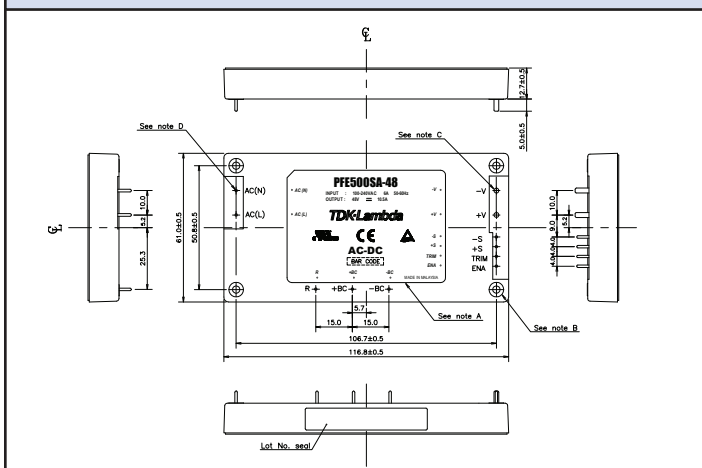

## PFE500F Outline Drawing

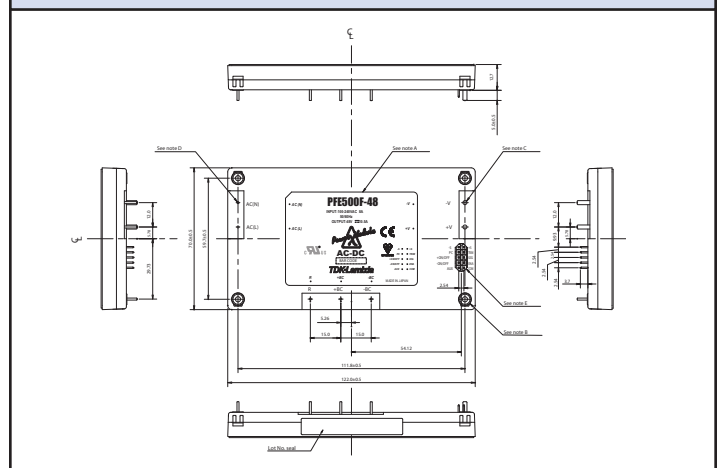

## PFE500SA Basic connection

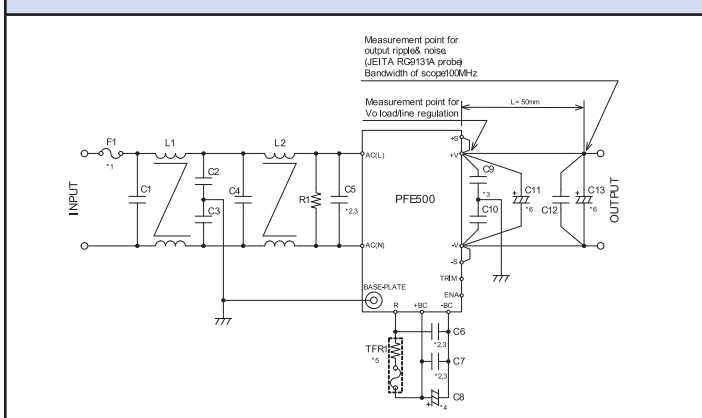

## Heatsink Table

Heatsink	Size (mm)	PFE Module
HAF-10L	116.8 x 25.4 x 61	PFE300/500SA
HAF-15L	116.8 x 38.1 x 61	PFE300/500SA
HAF-15T	116.8 x 38.1 x 61	PFE300/500SA
HAL-F12T	122 x 35 x 69.9	PFE500F
HAM-F10T	160 x 33.4 x 100	PFE1000FA

## Options

Suffix	Description
Blank	M3 tapped mounting inserts (4)
/T	3.3mm non-threaded inserts (4)

For additional information, please visit  
<https://product.tdk.com/en/power/>

