

BYZ50A22 ... BYZ50A47 | BYZ50K22 ... BYZ50K47
Press-Fit Diodes – Protectifiers®
Einpress-Dioden – Protectifiers®

$I_{FAV} = 50 \text{ A}$ $V_{WM} = 17.8 \dots 38.1 \text{ V}$
 $V_F < 1.1 \text{ V}$ $V_{BR \text{ Min}} = 19.8 \dots 42.3 \text{ V}$
 $T_{jmax} = 200^\circ\text{C}$ $I_{FSM} = 400/450 \text{ A}$

Version 2018-01-08

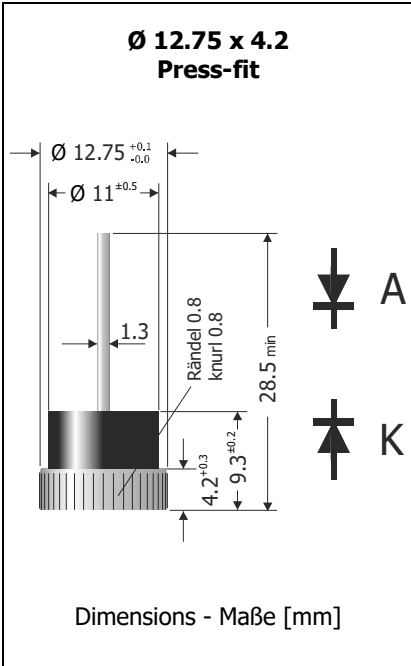

Typical Applications

On-board alternators
 Load dump protection
 Commercial grade ¹⁾

Features

TVS (suppressor) characteristic
 High junction temperature
 Press-fit assembly into aluminum plate
 Two polarity versions:
 A = Anode to lead wire
 K = Cathode to lead wire
 Compliant to RoHS, REACH,
 Conflict Minerals ¹⁾

Mechanical Data ¹⁾

Packed in cardboard trays 300
 Weight approx. 10 g
 Case material UL 94V-0
 Solder & assembly conditions 260°C/10s
 MSL N/A



Typische Anwendungen

Bordnetz-Generatoren
 "Load dump"-Schutz
 Standardausführung ¹⁾

Besonderheiten

TVS-(Begrenzer-)Charakteristik
 Hohe Sperrschichttemperatur
 Einpressmontage in Alu-Kühlblech
 Zwei Polaritäten:
 A = Anode am Anschlussdraht
 K = Kathode am Anschlussdraht
 Konform zu RoHS, REACH,
 Konfliktmineralien ¹⁾

Mechanische Daten ¹⁾

Verpackt in Einlegekartons
 Gewicht ca.
 Gehäusematerial
 Löt- und Einbaubedingungen

Maximum ratings ²⁾

Grenzwerte ²⁾

Max. average forward current – Dauergrenzstrom	$T_C = 150^\circ\text{C}$ ³⁾	I_{FAV}	50 A
Repetitive peak forward current – Periodischer Spitzenstrom	$f > 15 \text{ Hz}$ $T_C = 150^\circ\text{C}$ ³⁾	I_{FRM}	80 A
Peak forward surge current Stoßstrom in Fluss-Richtung	Half sine-wave 50 Hz (10 ms) Sinus-Halbwellen 60 Hz (8.3 ms)	I_{FSM}	400 A 450 A
Rating for fusing – Grenzlastintegral	$t < 10 \text{ ms}$	i^2t	800 A ² s
Junction temperature – Sperrschichttemperatur Storage temperature – Lagerungstemperatur		T_j T_s	-50...+200°C -50...+200°C
Peak junction temperature in case of load dump Spitzenperrschichttemperatur im "Load dump" Fall	$t < 400 \text{ ms}$	T_{JM}	+215°C
Maximum pressing force – Maximaler Einpressdruck		F_{pM}	4 kN

Characteristics ($T_j = 25^\circ\text{C}$)

Kennwerte ($T_j = 25^\circ\text{C}$)

Type / Typ		Breakdown voltage Abbruchspannung $I_T = 100 \text{ mA}$		Reverse voltage Sperrspannung $I_R = 5 \mu\text{A}$	Max. clamping voltage Max. Begrenzerspannung at / bei $I_{pp}, t_p = 1 \text{ ms}$	
Wire to / Draht an		$V_{BRmin} \text{ [V]}$	$V_{BRmax} \text{ [V]}$	$V_R \text{ [V]}$	$V_C \text{ [V]}$	$I_{pp} \text{ [A]}$
Anode	Cathode					
BYZ50A22	BYZ50K22	19.8	24.2	> 17.8	31.9	235
BYZ50A33	BYZ50K33	29.7	36.3	> 26.8	47.7	157
BYZ50A39	BYZ50K39	35.1	42.9	> 31.6	56.4	133
BYZ50A47	BYZ50K47	42.3	51.7	> 38.1	67.8	111

1 Please note the [detailed information on our website](#) or at the beginning of the data book
 Bitte beachten Sie die [detaillierten Hinweise auf unserer Internetseite](#) bzw. am Anfang des Datenbuches
 2 $T_A = 25^\circ\text{C}$ unless otherwise specified – $T_A = 25^\circ\text{C}$ wenn nicht anders angegeben
 3 Temperature measured at the metallic base – Temperatur am Metallsockel gemessen

Characteristics
Kennwerte

Forward voltage Durchlass-Spannung	$T_j = 25^\circ\text{C}$ $I_F = 50\text{ A}$	V_F	< 1.1 V
Typical junction capacitance Typische Sperrschichtkapazität		$V_R = 4\text{ V}$	C_j 430 pF
Reverse recovery time Sperrverzug	$I_F = 0.5\text{ A}$ through/über $I_R = 1\text{ A}$ to $I_R = 0.25\text{ A}$	t_{rr}	typ. 1500 ns
Thermal resistance junction to case Wärmewiderstand Sperrschicht – Gehäuse		R_{thc}	< 0.6 K/W ¹⁾

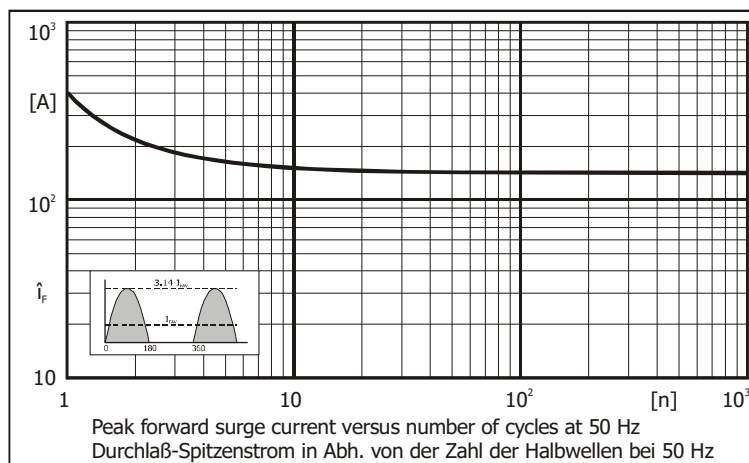
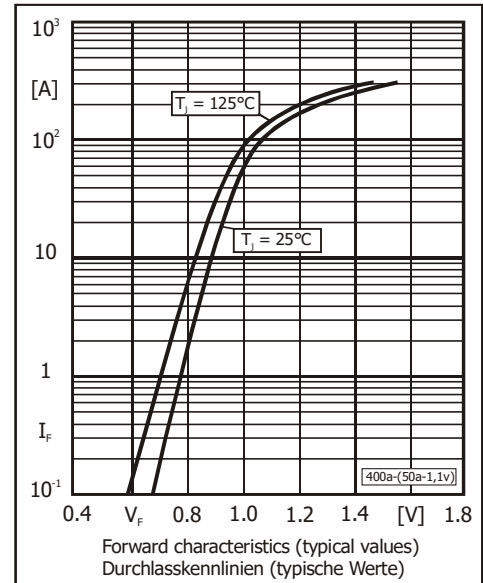
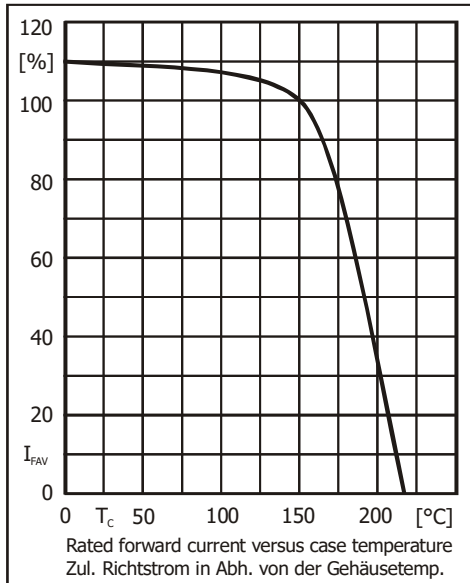

Disclaimer: See data book page 2 or [website](#)
Haftungsausschluss: Siehe Datenbuch Seite 2 oder [Internet](#)

1 Temperature measured at the metallic base – Temperatur am Metallsockel gemessen