

DIN-Power D032-FC-B-modul



Image is for illustration purposes only. Please refer to product description.

Part number	09 04 032 3215
Specification	DIN-Power D032-FC-B-modul
HARTING eCatalogue	https://harting.com/09040323215

Identification

Category	Connectors
Series	DIN 41612
Identification	Type D
Element	Female connector

Version

Termination method	Crimp termination
Connection type	PCB to cable
Number of contacts	32
Coding	Hole coding Coding with loss of contacts
PCB fixing	With fixing flange
Details	Please order crimp contacts separately.

Technical characteristics

Contact rows	2
Contact spacing (termination side)	5.08 mm
Contact spacing (mating side)	5.08 mm
Rated current	Rated current measured at 20 °C, see derating curve for details
Clearance distance	≥1.6 mm
Creepage distance	≥3 mm
Insulation resistance	>10 ¹² Ω
Contact resistance	≤20 mΩ



Pushing Performance
Since 1945

Technical characteristics

Limiting temperature	-55 ... +125 °C
Insertion force	≤40 N
Withdrawal force	≤40 N
Test voltage $U_{r.m.s.}$	1.55 kV (contact-contact) 1.55 kV (contact-ground)
Isolation group	IIIa ($175 \leq CTI < 400$)
Hot plugging	No

Material properties

Material (insert)	Thermoplastic resin, glass-fibre filled
Colour (insert)	RAL 7032 (pebble grey)
Material flammability class acc. to UL 94	V-0
RoHS	compliant
ELV status	compliant
China RoHS	e
REACH Annex XVII substances	Not contained
REACH ANNEX XIV substances	Not contained
REACH SVHC substances	Not contained

Specifications and approvals

Specifications	IEC 60603-2
UL / CSA	UL 1977 ECBT2.E102079 CSA-C22.2 No. 182.3 ECBT8.E102079
Railway classification	F1/I2 acc. to NFF 16-101/102

Commercial data

Packaging size	60
Net weight	14 g
Country of origin	Germany
European customs tariff number	85366990
GTIN	5713140008229
eCl@ss	27460201 PCB connector (board connector)
ETIM	EC002637
UNSPSC 24.0	39121415

Current carrying capacity

The current carrying capacity of the connectors is limited by the thermal load capability of the contact element material including the connections and the insulating parts. The derating curve is therefore valid for currents which flow constantly (non-intermittent) through each contact element of the connector evenly, without exceeding the allowed maximum temperature.

Measuring and testing techniques acc. to IEC 60512-5-2

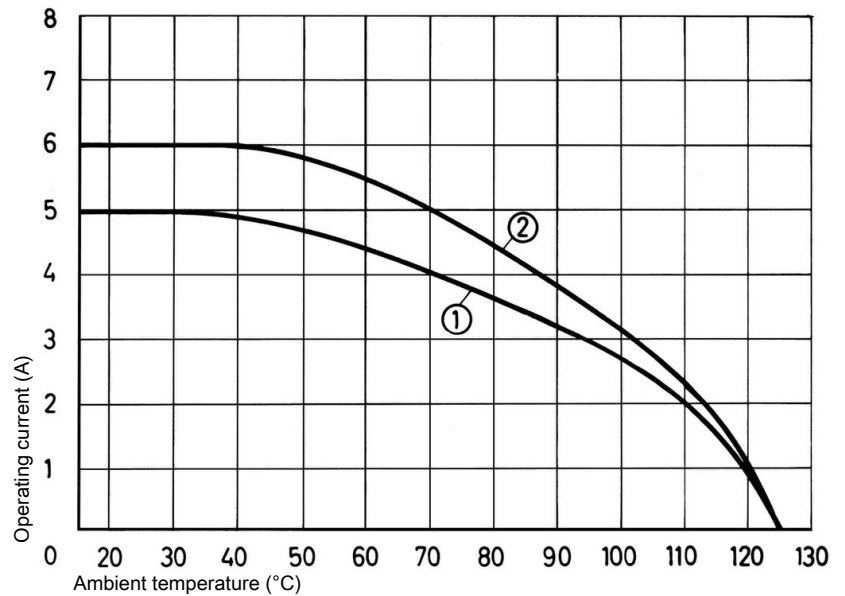

- ① with shell housing
- ② Without shell housing

Hole coding

(without loss of contact)

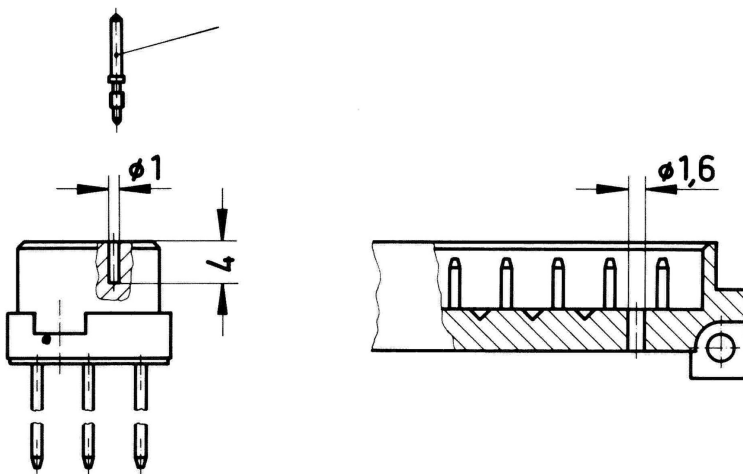

To avoid cross-plugging of adjacent connectors a coding system is required.

Drill out the male connector at pre-centered point according to the sketch. Use the setting tool 09 99 000 0103 to insert the coding pin 09 06 000 9950 into the existing hole in the female connector.

Coding with loss of contacts

To avoid cross-plugging of adjacent connectors a coding system is required.

The coding is achieved by means of a code pin which is inserted into the selected chamber of the female connector (the contact cavity must be filled with a female contact!).

The opposite male contact must be removed with the help of the specially designed tool. It's recommended to use at least 3 pins.

Coding pin 09 04 000 9908

Removal tool for male contacts 09 99 000 0038

Installation of crimp contacts

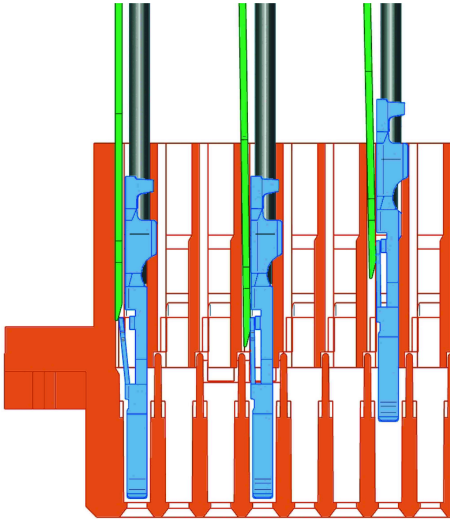

Fitting the crimp contacts:

After crimping the wires onto the contacts with the help of a crimping tool or an automatic crimping machine the contacts should be correctly oriented and inserted into the cavities of the connector moulding in the required configuration. They snap into position and are firmly held in place. A light pull on the wire assures the correct tensile strength of the contact. When using stranded wires with a gauge below 0.37 mm^2 an insertion tool is necessary. Insertion tool part number: 09 99 000 0100

Insertion tool part number: 09 99 000 0088

Removing the crimp contacts:

The removal tool is inserted into a slot on the side of the respective crimp cavity. This action compresses the contact retaining spring therefore the contact can then be easily withdrawn using a light pull on the wire. This action will cause no damage to the contact / wire which can be repositioned / refitted as necessary. The drawing demonstrates the crimp removal procedure (max. 5x).

Removal tool part number: 09 99 000 0087

Mating conditions

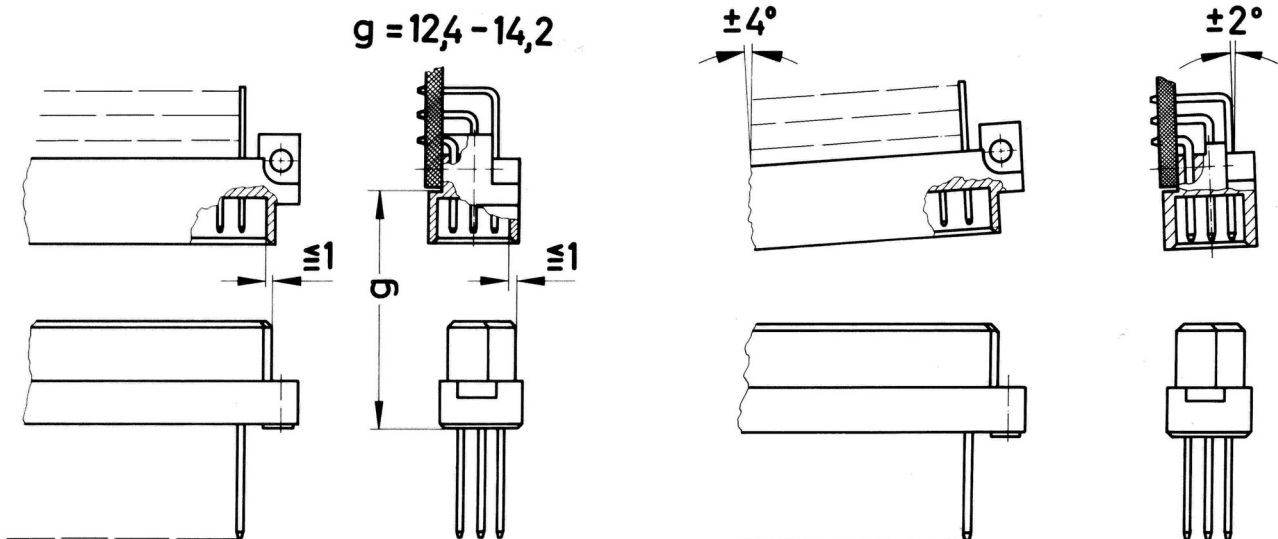

To ensure reliable connections and prevent unnecessary damage, please refer to the application data diagrams. These recommendations are set out in IEC 60603-2. The connectors should not be coupled and decoupled under electrical load.