

**SECTION A-A**

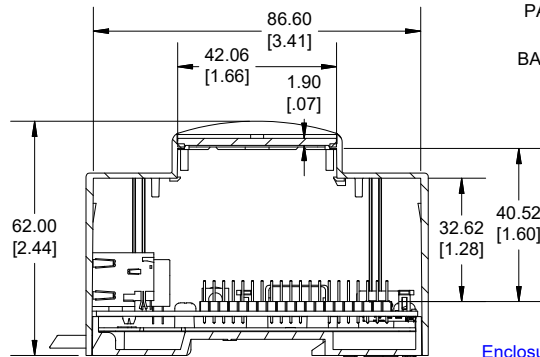

**SECTION B-B**

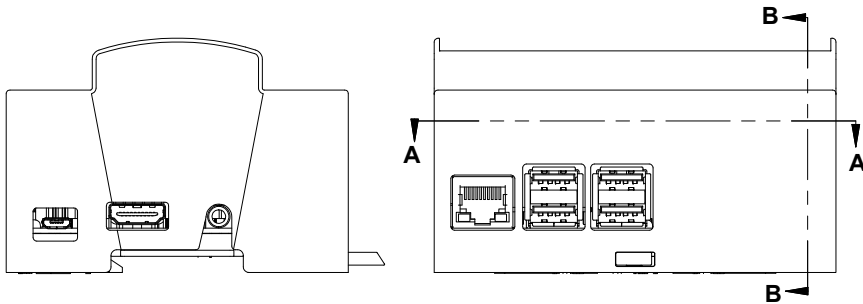
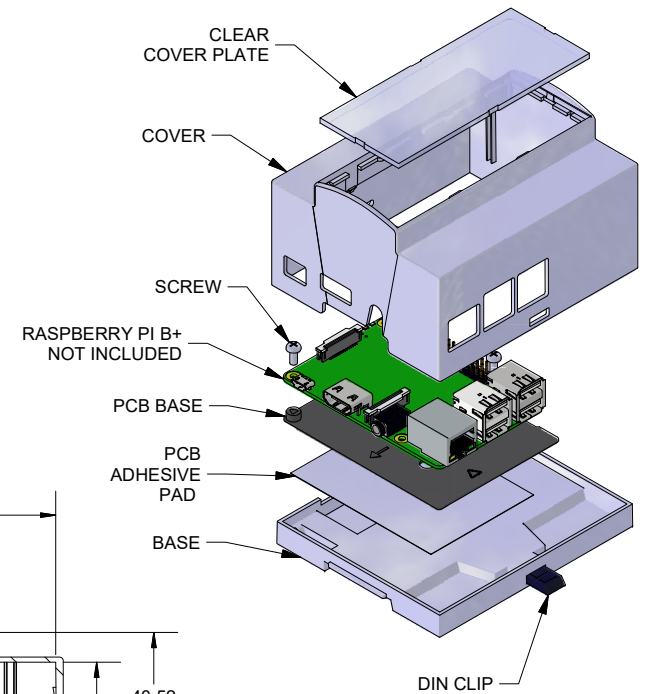

Enclosures can be Factory Modified (Milling, Drilling, Printing etc.)  
 Contact Factory ([modshop@hammfg.com](mailto:modshop@hammfg.com)) for quotes  
 Solid models of this enclosure available in .stp or .x\_t  
 (Part number and text placement/orientation on our products are subject to change,  
 we do not recommend using them as a locating reference for modification purposes)

NOTE	
Purchased enclosure includes base, cover, cover plate, PC holding board, PCB stick pad, screws and din clip.	
Enclosure is made from PC ABS, din clip made from PPO.	
Enclosure made to use with the Raspberry PI B+ development board	
Recommended PCB screw torque -- 28.0-35.5 ozf-in (20-25 cN-m)	

PART NUMBERS	
1597KIT	
Development board enclosure grey	1597KIT6MPIB
ACCESSORIES	
P.C. Board Self Tapping Screw	1593ATS50 (Pkg 50)
[#4 X 1/4" (6.4mm) Plated]	1593ATS100 (Pkg 100)
DIN CLIP	1597DINCLIPXT

**HAMMOND  
MANUFACTURING®**  
**1597KIT6MPIB**  
[www.hammondmfg.com](http://www.hammondmfg.com)

Dimensions:  
 mm  
 [inches]