

R3G280-RU26-81

EC centrifugal fan - RadiCal

backward-curved, single-intake

for rail applications



ebm-papst Mulfingen GmbH & Co. KG

Bachmühle 2 · D-74673 Mulfingen

Phone +49 7938 81-0

Fax +49 7938 81-110

info1@de.ebmpapst.com

www.ebmpapst.com

Limited partnership · Headquarters Mulfingen

Amtsgericht (court of registration) Stuttgart · HRA 590344

General partner Elektrobau Mulfingen GmbH · Headquarters Mulfingen

Amtsgericht (court of registration) Stuttgart · HRB 590142

Nominal data

Type	R3G280-RU26-81	
Motor	M3G084-CF	
Nominal voltage	VDC	26
Nominal voltage range	VDC	16 .. 32
Method of obtaining data		fa
Speed (rpm)	min ⁻¹	2350
Power consumption	W	252
Current draw	A	10.5
Min. ambient temperature	°C	-40
Max. ambient temperature	°C	70

ml = Max. load · me = Max. efficiency · fa = Free air · cs = Customer specification · ce = Customer equipment
Subject to change



Technical description

Weight	3.06 kg
Size	280 mm
Motor size	84
Rotor surface	Painted black
Electronics housing material	Die-cast aluminum, painted black
Impeller material	PA plastic UL94 V0
Number of blades	6
Direction of rotation	Clockwise, viewed toward rotor
Degree of protection	Motor IP24 KM, electronics IP6K9K (mating connector installed)
Insulation class	"B"
Moisture (F) / Environmental (H) protection class	H3
Max. permitted ambient temp. for motor (transport/storage)	+80 °C
Min. permitted ambient temp. for motor (transport/storage)	-40 °C
Installation position	Any
Condensation drainage holes	None
Cooling hole/opening	On rotor side
Mode	S1
Motor bearing	Ball bearing; (sealed)
Technical features	<ul style="list-style-type: none"> - Lowering input - Error output (high-side switch) - INVLIN (inverse linear control input) - Power limiter - Load dump (58 V) - Motor current limitation - Soft start - Control input 0-10 VDC / PWM - Temperature derating - Overvoltage detection - Thermal overload protection for electronics - Line undervoltage detection - Reverse polarity protection
EMC regulations	According to EN 50121-3-2
Electrical hookup	Standby current less than 500 µA
With cable	Lateral
Protection class assignment	<p>III; Requires supply with safety extra-low voltage SELV.</p> <p>This component for installation may have several local protection classes. This information relates to this component's basic design.</p> <p>The final protection class is based on the component's intended installation and connection.</p>
Conformity with standards	EN 15085-1, CPC3; EN 45545-2, HL3; EN 50155; EN 61373, Cat. 1B
Approval	EAC

EC centrifugal fan - RadiCal

backward-curved, single-intake
for rail applications

Product drawing

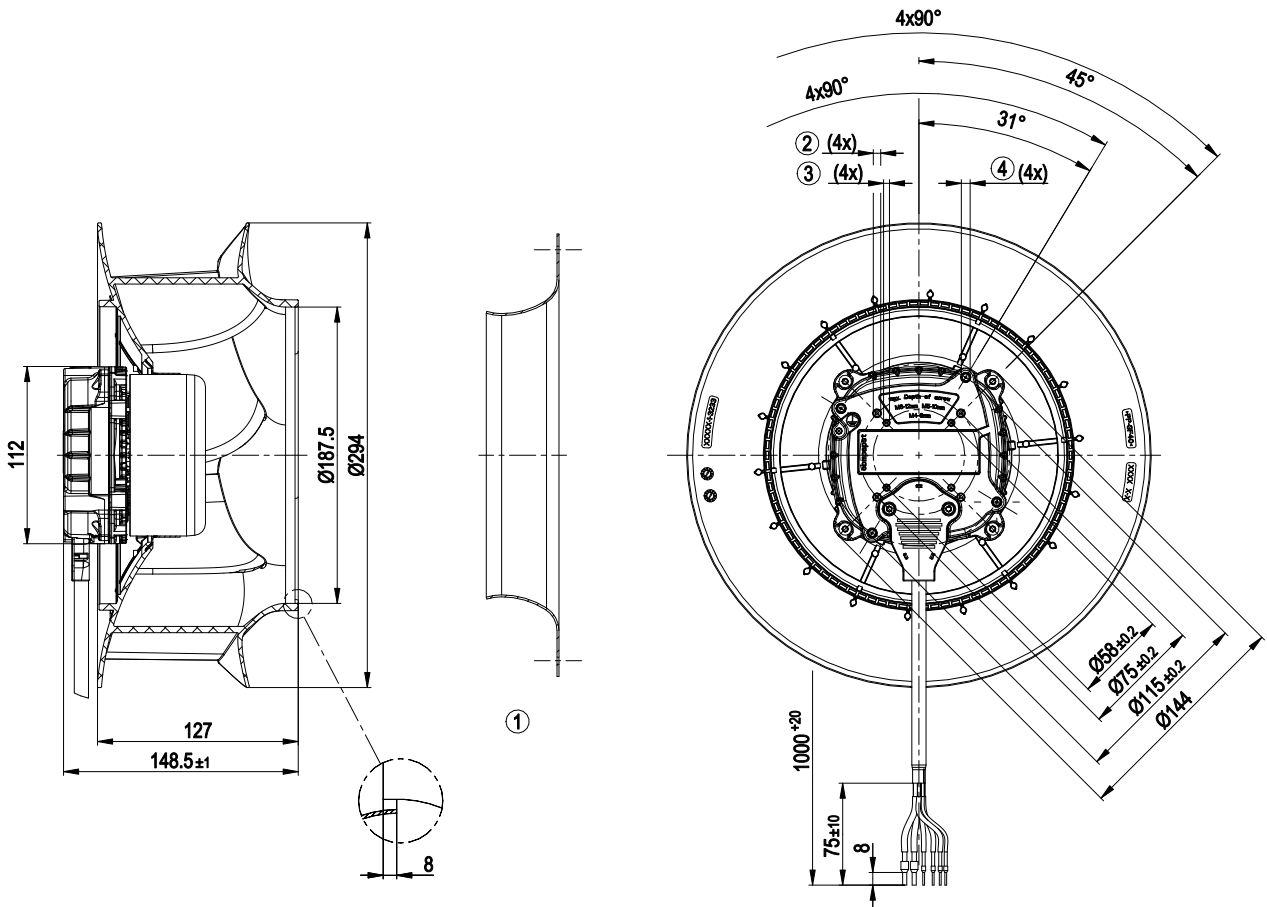

- | | |
|---|---|
| 1 | Accessory part: inlet ring 28000-2-4013 not included in scope of delivery. |
| 2 | Max. clearance for screw 10 mm, tapping hole ready for self-tapping M5 screw |
| 3 | Max. clearance for screw 8 mm, tapping hole ready for self-tapping M4 screw |
| 4 | Max. clearance for screw 12 mm, tapping hole ready for self-tapping M6 screw |
| 5 | Cable (railway) 2x 2.5 mm ² , 4x 1.0 mm ² , 6x crimped ferrules |



EC centrifugal fan - RadiCal

backward-curved, single-intake

for rail applications

Accessory part

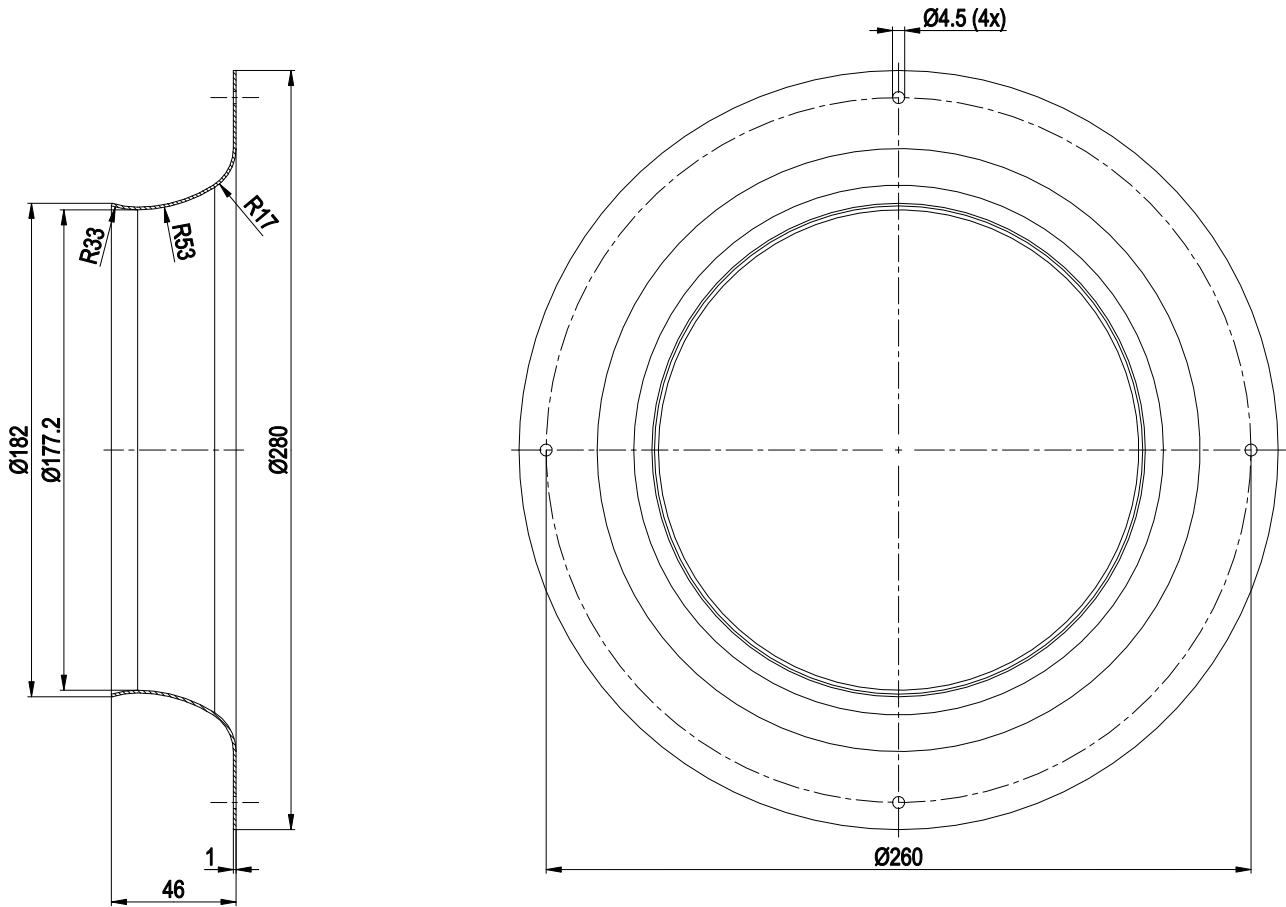

Inlet ring 28000-2-4013



EC centrifugal fan - RadiCal

backward-curved, single-intake

for rail applications

Connection diagram

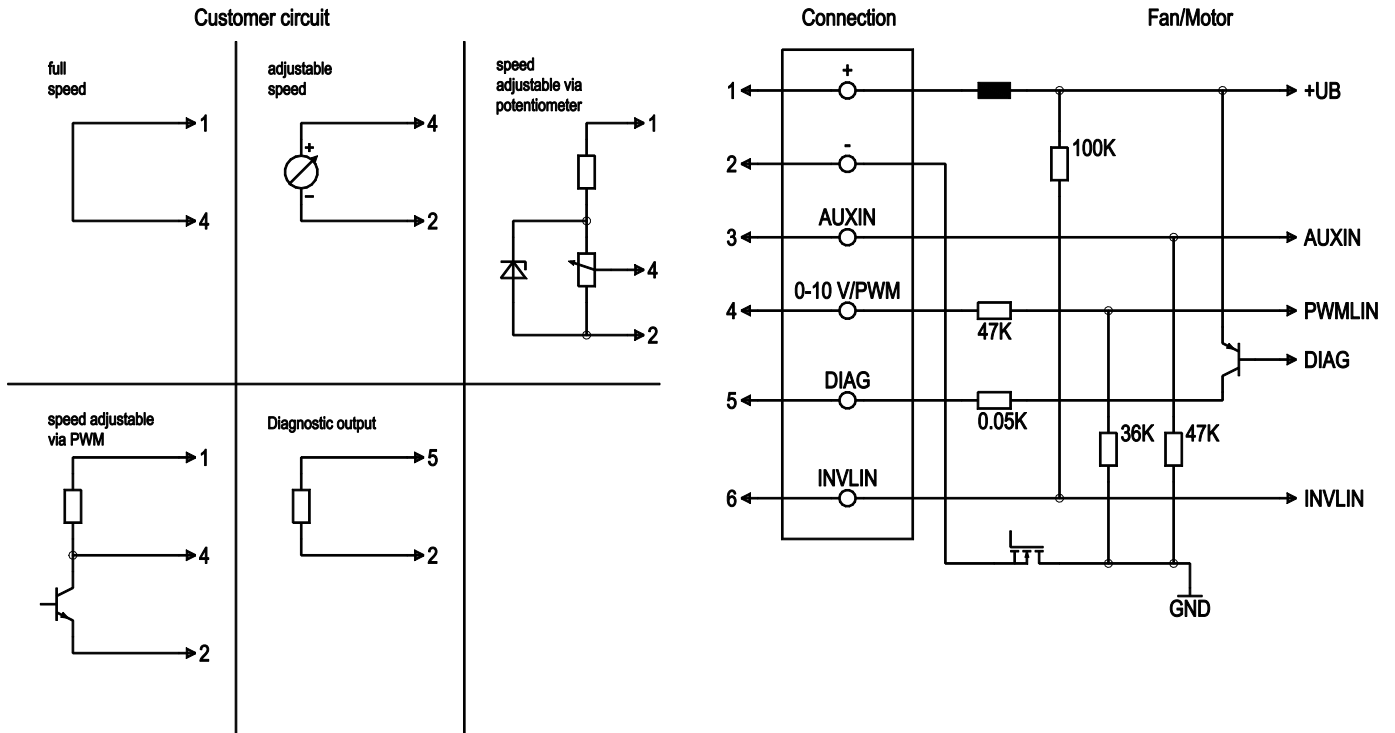

No.	Conn.	Designation	Color	Function/assignment
	1	+	black	Power supply, see nameplate for voltage range
	2	-	brown	Power supply, see nameplate for voltage range
	3	AUXIN	blue	Digital input: when active (> 4 V), value of PWM signal is halved
	4	0-10 V / PWM	yellow	Control input: $R_i > 47\text{ k}\Omega$ 0-10 V (typ. < 1 V -> n=0; 1.5 V -> n=min; > 10 V -> n=max) PWM (amplitude 10 V; 1-50 kHz; typ. < 5 % -> n=0; 15% -> n=min; > 100% -> n=max)
	5	DIAG	white	Diagnostic output: Open collector, $I_{\text{source max}} = 20\text{ mA}$, Fan OK -> low; fan error -> high
	6	INVLIN	orange	Control input, inverse linear



Curves: Air performance

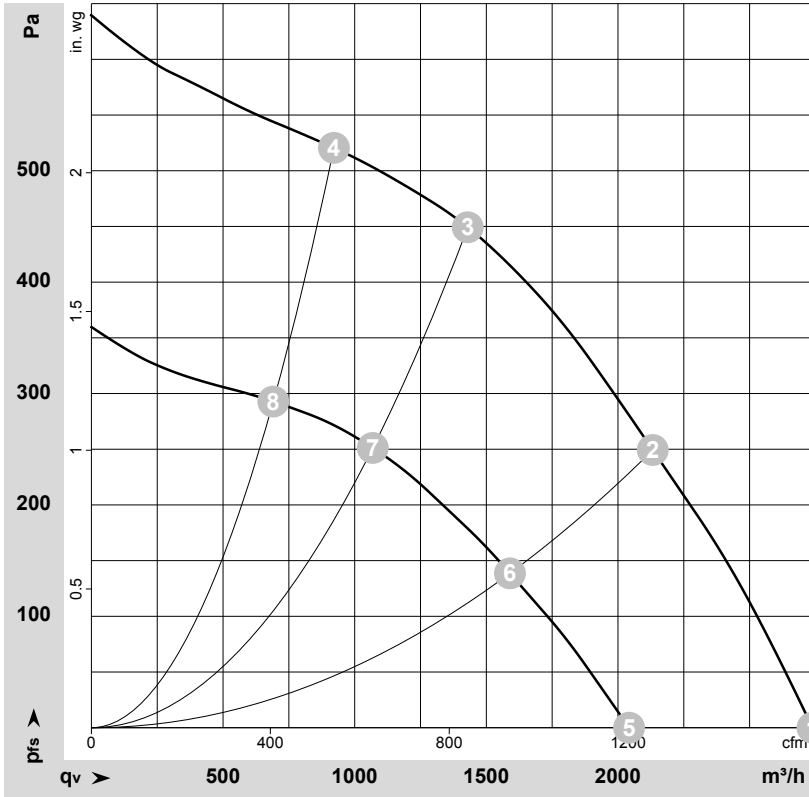

$\rho = 1.15 \text{ kg/m}^3 \pm 2 \%$

Measurement: LU-160664-1
Measurement: LU-160865-1

Air performance measured according to ISO 5801 installation category A. For detailed information on the measurement setup, contact ebm-papst. Intake sound level: Sound power level according to ISO 13347 / sound pressure level measured at 1 m distance from fan axis. The values given are valid under the specified measuring conditions and may vary due to conditions of installation. For deviations from the standard configuration, the parameters have to be checked on the installed unit.

Measured values

	U	n	P _{ed}	I	LpA _{in}	LwA _{in}	q _v	P _{fs}	q _v	P _{fs}
	V	min ⁻¹	W	A	dB(A)	dB(A)	m ³ /h	Pa	cfm	in. wg
1	24-32	2350	252	10.50*	72	80	2740	0	1610	0.00
2	24-32	2280	298	12.40*	69	75	2130	250	1255	1.00
3	24-32	2265	304	12.60*	67	73	1430	450	840	1.81
4	24-32	2305	280	11.70*	68	74	920	520	540	2.09
5	16	1745	107	6.70			2040	0	1200	0.00
6	16	1715	124	7.77			1590	139	935	0.56
7	16	1700	133	8.33			1070	251	630	1.01
8	16	1730	119	7.48			690	293	405	1.18

U = Voltage · n = Speed (rpm) · P_{ed} = Power consumption · I = Current draw · * = Current measured at nominal voltage · LpA_{in} = Sound pressure level intake side · LwA_{in} = Sound power level intake side
q_v = Air flow · P_{fs} = Pressure increase

