

DATASHEET

Type	Whip Antenna
Frequencies	AMPS (824-894 MHz) ISM (868 MHz) GSM (900 MHz) DCS (1800 MHz) PCS (1900 MHz) 3G (UMTS 2.1 GHz) WIFI / BLUETOOTH (2.4 GHz)
Mounting	Body Mount
Part No.	2J120BF
Revision	00



1. SPECIFICATION

1.1. Electrical Specifications

Frequencies	AMPS (824-894 MHz) ISM (868 MHz) GSM (900 MHz) DCS (1800 MHz) PCS (1900 MHz) 3G (UMTS 2.1 GHz) WIFI / BLUETOOTH (2.4 GHz)
Impedance	50 Ohms
Polarization	VERTICAL
Gain	0dBi
VSWR	<2:1
Power handling	100W
Operating temperature	-40°C to +85°C

1.2. Connection Specifications

Cable and connector: Upon request
Cable length: min. 2.5 m

1.3. Mechanical Specifications and Dimensions

1.3.1. Mounting Type

- Body Mount

1.3.2. Body mount

Max. dimensions: 29mm x 76mm
Weight: 140 g 'weight with 2.5m cable'
Colour: Black (for different colours please ask our sales team)

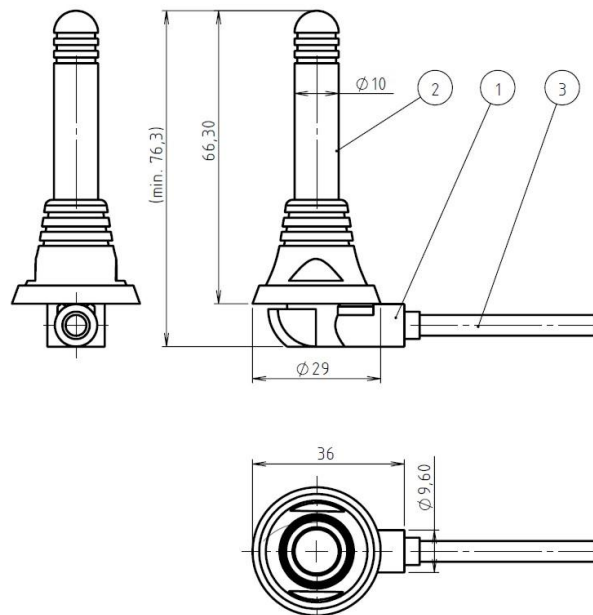

2. MEASUREMENT

3D radiation pattern for 868MHz

Freq = 0.898GHz Az= 45 EL= 45

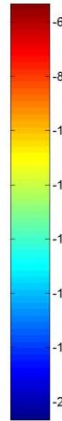
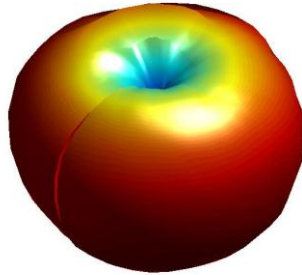

Measured with 2.5m cable length

3D plane radiation for 898MHz

Freq = 0.898GHz

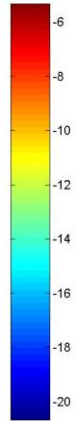
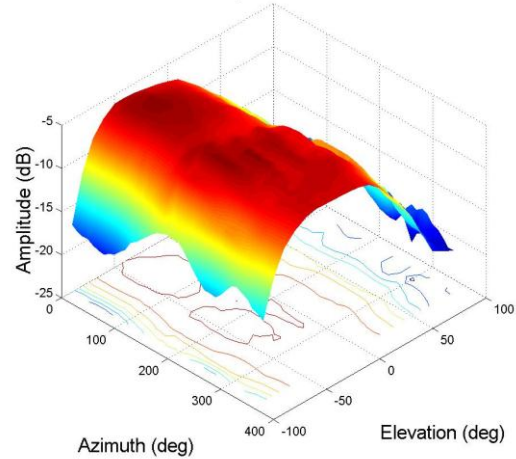

Tested with 2.5m cable length

VSWR (Quad Band)

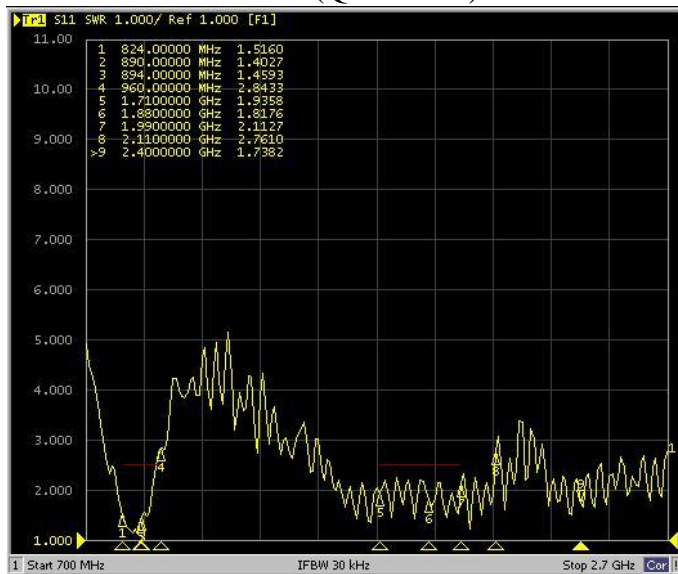

Tested with 2.5m cable length

Log Mag (Quad Band)

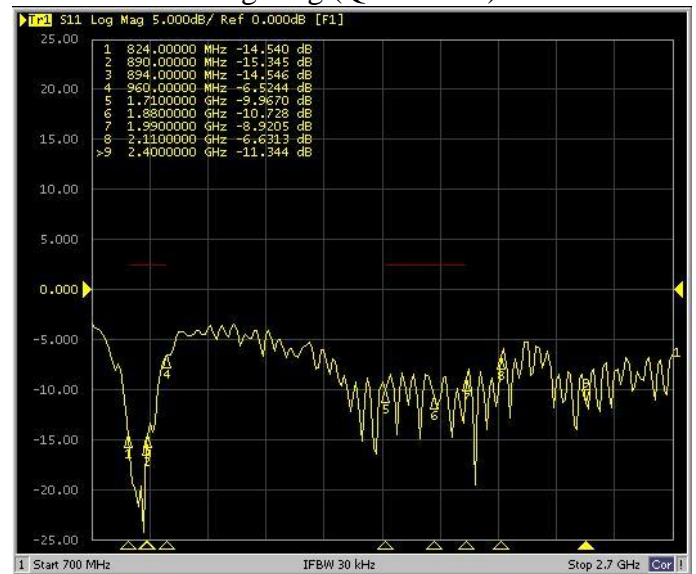

Tested with 2.5m cable length