

## M12 transf. 10/100BASE-T d STR with PoE



Image is for illustration purposes only. Please refer to product description.

Part number	21 03 381 2411
Specification	M12 transf. 10/100BASE-T d STR with PoE
HARTING eCatalogue	<a href="https://b2b.harting.com/21033812411">https://b2b.harting.com/21033812411</a>

### Identification

Category	Connectors
Series	Circular connectors M12
Identification	Magnetics
Element	PCB adapter
Specification	with integrated transformer Straight Power over Ethernet (PoE+)

### Version

Termination method	Reflow soldering termination (SMT)
Gender	Female
Shielding	Shielded
Number of contacts	4
Coding	D-coding
Details	Order housings separately
Pack contents	60 pieces in a tray

### Technical characteristics

Rated current	3 A
Rated voltage	57 V
Rated impulse voltage	1.5 kV
Pollution degree	3
Transmission characteristics	Cat. 5 Class D up to 100 MHz



Pushing Performance  
 Since 1945

## Technical characteristics

Data rate	10 Mbit/s 100 Mbit/s
Insulation resistance	$>10^8 \Omega$
Contact resistance	$\leq 10 \text{ m}\Omega$
Limiting temperature	-40 ... +85 °C (during reflow soldering max. +245)
Insertion force	10 N
Withdrawal force	15 N
Mating cycles	$\geq 100$
Degree of protection acc. to IEC 60529	IP65 / IP67 mated condition
Isolation group	IIIa ( $175 \leq \text{CTI} < 400$ )
Process Sensitivity Level (PSL)	R7 acc. to ECA/IPC/JEDEC J-STD-075

## Material properties

Material (insert)	Liquid crystal polymer (LCP)
Colour (insert)	Black
Material (contacts)	Brass
Surface (contacts)	Au over Ni Mating side
Material flammability class acc. to UL 94	V-0
RoHS	compliant with exemption
RoHS exemptions	6(c): Copper alloy containing up to 4 % lead by weight
ELV status	compliant with exemption
China RoHS	50
REACH Annex XVII substances	Not contained
REACH ANNEX XIV substances	Not contained
REACH SVHC substances	Yes
REACH SVHC substances	Lead
ECHA SCIP number	0d7d3693-d625-47ab-934a-d241bf72c86e
California Proposition 65 substances	Yes
California Proposition 65 substances	Lead Nickel Naphthalene
Fire protection on railway vehicles	EN 45545-2 (2020-08)
Requirement set with Hazard Levels	R26

## Specifications and approvals

Specifications	IEC 61076-2-101
----------------	-----------------

## Commercial data

Packaging size	60
Net weight	0.1 g
Country of origin	China
European customs tariff number	85366990
GTIN	5713140228832
ETIM	EC002637
eCl@ss	27460201 PCB connector (board connector)

## Panel cut out

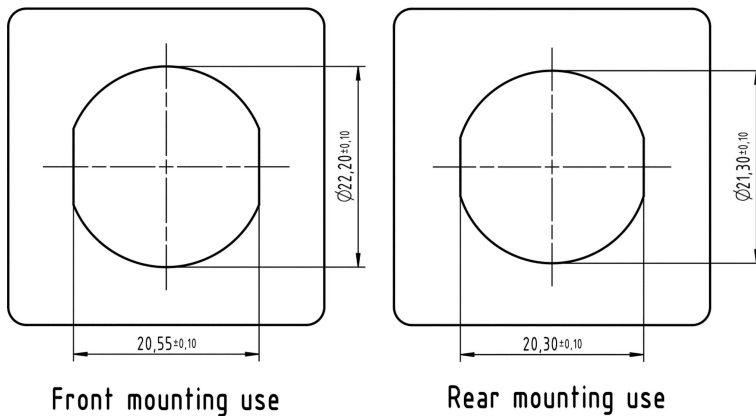

## General information

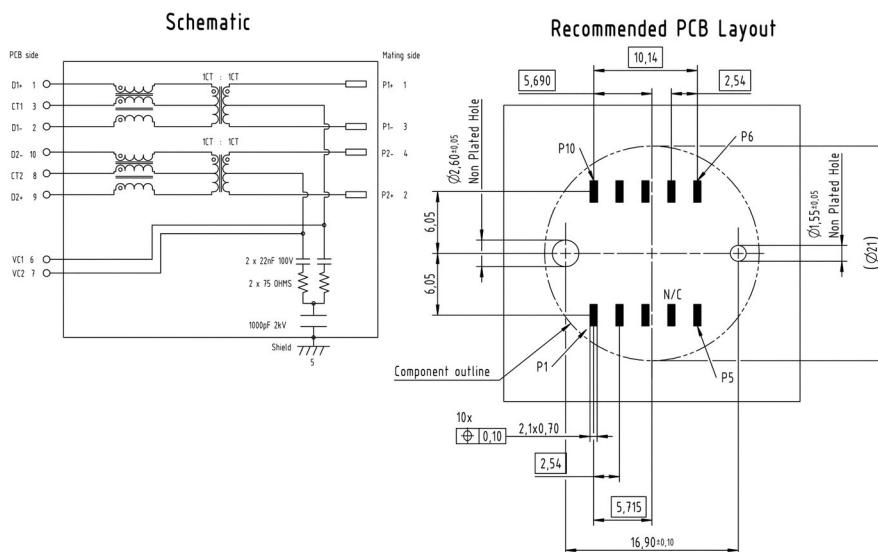

Electrical Characteristics @+25°C unless otherwise noted  
 Meets IEEE802.3 specification  
 RoHS compliant

Parameter	Specification/ Limit Values
Operating Temperature	-40°C - +85°C
Turn Ratio (+/- 2%)	1CT - 1CT
Current Capacity Pins 1-B/ VC1-VC4	750mA DC
OCL	min 350µH @ 100KHz , 100mV with 8mA bias current
Isolation (Input- Output)	2.25kV VDC , for 60sec. min f ≤ 100MHz
Insertion Loss	1.3 dB
Return Loss	9 dB
Crosstalk	30 dB
CMRR	30 dB
CDMR	30 dB

NOTE: 1. f is the frequency in MHz  
 2. The Product has been tested for DC isolation. HARTING assumes no liability or obligation for AC isolation testing.

### Tape layout & packaging

