

Display Elektronik GmbH

# DATA SHEET

*TFT MODULE*

**DEM 800320A3 TMH-PW-N  
(A-TOUCH)**

**4,6" TFT + TP**

Product Specification

Ver.: 2

08.03.2023

**Revision History**

<b>Revision</b>	<b>Date</b>	<b>Originator</b>	<b>Detail</b>	<b>Remarks</b>
0	12.12.2023	LL	Initial Release	
1	18.12.2023	LL	Modify Optical Characteristics	P7
2	08.03.2024	LL	Modify Module Parameter Modify Absolute Maximum Ratings Modify AC electrical characteristics Modify Outline Drawing(B)	P4 P4 P12 P27

**Table of Contents**

No.	Item	Page
1.	General Description.....	4
2.	Module Parameter.....	4
3.	Absolute Maximum Ratings.....	4
4.	DC Characteristics .....	5
5.	Backlight Characteristic.....	5
5.1.	Backlight Characteristics .....	5
5.2.	Backlighting circuit.....	5
6.	Touch Screen Panel Specifications .....	6
7.	Optical Characteristics .....	7
7.1.	Optical Characteristics .....	7
7.2.	Definition of Response Time .....	7
7.3.	Definition of Contrast Ratio .....	8
7.4.	Definition of Viewing Angles .....	8
7.5.	Definition of Color Appearance.....	9
7.6.	Definition of Surface Luminance, Uniformity and Transmittance .....	9
8.	Block Diagram and Power Supply.....	10
9.	Interface Pins Definition .....	11
10.	AC electrical characteristics .....	12
10.1.	Parallel 24-bit RGB Mode.....	12
10.2.	Input Clock and Data Timing Diagram.....	12
10.3.	Power ON/OFF Sequence .....	13
11.	Quality Assurance .....	14
11.1.	Purpose.....	14
11.2.	Standard for Quality Test .....	14
11.3.	Nonconforming Analysis & Disposition.....	14
11.4.	Agreement Items.....	14
11.5.	Standard of the Product Visual Inspection .....	14
11.6.	Inspection Specification.....	15
11.7.	Classification of Defects .....	19
11.8.	Identification/marketing criteria.....	19
11.9.	Packing .....	19
12.	Reliability Specification.....	20
13.	Precautions and Warranty .....	21
13.1.	Safety .....	21
13.2.	Handling .....	21
13.3.	Storage .....	21
13.4.	13.4 Metal Pin (Apply to Products with Metal Pins).....	21
13.5.	Operation.....	22
13.6.	Static Electricity .....	22
13.7.	Limited Warranty .....	22
14.	Outline Drawing.....	23

**1. General Description**

The specification is a transmissive type color active matrix liquid crystal display (LCD) which uses amorphous thin film transistor (TFT) as switching devices. This product is composed of a TFT-LCD panel, driver Ics, a touch panel and a backlight unit.

**2. Module Parameter**

Features	Details	Unit
Display Size(Diagonal)	4.6"	
LCD type	TN TFT	
Display Mode	Normally White/Transmissive	
Resolution	800 RGB x 320	Pixels
View Direction	12 O'clock	Best Image
Gray Scale Inversion Direction	6 O'clock	
Module Outline	120.7 (H) x 57.08(V) x 4.35(T) (Note1 )	mm
Active Area	108 (H) x 43.2(V)	mm
Pixel Size	135 (H) x 135(V)	um
Pixel Arrangement	R.G.B Stripe	
Driver IC	ST5625CA&ST5091CA	
Display Colors	16.7M	
Interface	24-bit RGB interface	
With or Without Touch Panel	With	
Operating Temperature	-20~70	°C
Storage Temperature	-30~80	°C
Weight	TBD	g

Note 1: Exclusive hooks, posts, FFC/FPC tail etc.

**3. Absolute Maximum Ratings**

V<sub>SS</sub>=0V, Ta=25°C

Item	Symbol	Min.	Max.	Unit
Supply Voltage	VDD	-0.5	5.0	V
Storage temperature	T <sub>STG</sub>	-30	+80	°C
Operating temperature	T <sub>OP</sub>	-20	+70	°C

Note 1: If Ta below 50°C, the maximal humidity is 90%RH, if Ta over 50°C, absolute humidity should be less than 60%RH.

Note 2: The response time will be extremely slow when the operating temperature is around -10°C, and the back ground will become darker at high temperature operating.

4. DC Characteristics

Item	Symbol	Min.	Typ.	Max.	Unit	
Supply Voltage	VDD	2.7	3.3	3.6	V	
Logic Low input voltage	V <sub>IL</sub>	0	-	0.3*VDD	V	
Logic High input voltage	V <sub>IH</sub>	0.7*VDD	-	VDD	V	
Logic Low output voltage	V <sub>OL</sub>	-	-	GND+0.4	V	
Logic High output voltage	V <sub>OH</sub>	VDD-0.4	-	-	V	
Current Consumption All Black	Logic Analog	I <sub>CC+</sub> I <sub>IN</sub>	-	TBD	-	mA

5. Backlight Characteristic

5.1. Backlight Characteristics

Item	Symbol	Condition	Min.	Typ.	Max.	Unit
Forward Voltage	V <sub>F</sub>	T <sub>a</sub> =25 °C, I <sub>F</sub> =20mA/LED	16.8	19.2	20.4	V
Forward Current	I <sub>F</sub>	T <sub>a</sub> =25 °C, V <sub>F</sub> =3.2V	-	60	-	mA
Power dissipation	P <sub>D</sub>		-	1152	-	mW
LED Life Time(25 °C)	-	-	20000	30000	-	Hr
Uniformity	Avg		-	80	-	%
Drive method	<b>Constant current</b>					
LED Configuration	18 White LEDs (6 LEDs in one string and 3 groups in parallel)					

Note: LED life time defined as follows: The final brightness is at 70% of original brightness.  
 The environmental conducted under ambient air flow, at T<sub>a</sub>=25±2 °C,60%RH±5%, I<sub>F</sub>=20mA/ LED.

5.2. Backlighting circuit

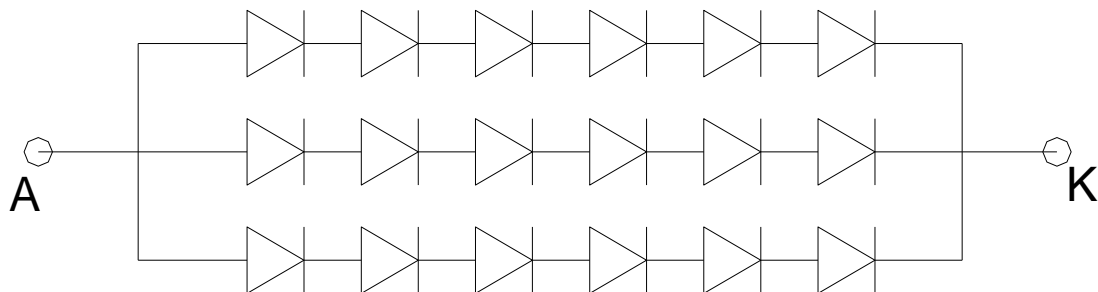

6. Touch Screen Panel Specifications

6.1 Electrical Characteristics

Item	Min.	Typ.	Max.	Unit	Note
Linearity	-1.5		1.5	%	Analog X and Y directions
Terminal resistance	300		1350	$\Omega$	X (Glass side)
	100		450	$\Omega$	Y (Film side)
Insulation resistance	(20)	-	-	M $\Omega$	
Voltage	-	-	5	V	DC
Chattering	-	-	15	ms	

Caution (1): Do not operate it with a thing except a polyacetal pen (tip R0.8mm or less) or a finger nail, especially those with hard or sharp tips such as a ball point pen or a mechanical pencil.

Caution (2): RTP operation must be followed the parameter condition.

Caution (3): If ask for use glare ITO film , it's will has newton issue

6.2 Mechanical & Reliability Characteristics

Item	Min.	Typ.	Max.	Unit	Note
Activation force	(20)	-	100	g	(1)
Durability-surface scratching	Write 20,000	-	-	characters	(2)
Durability-surface pitting	1,000,000	-	-	touches	(3)
Surface hardness	3	-	-	H	

Note (1) Stylus pen Input: R0.8mm polyacetal pen or Finger nail

Note (2) Measurement for Surface area

- Force: 150-250gf
- Speed: 60mm/sec
- Stylus: R0.8 polyacetal pen or Finger nail

Note (3) Pit 1,000,000 times on the Film with a R3.75 silicon rubber.

- Force: Force: 2.45N
- Speed: 3times/sec

7. Optical Characteristics

7.1. Optical Characteristics

Ta=25°C, VDD=3.3V

	Item	Symbol	Condition	Specification			Unit	
				Min.	Typ.	Max.		
Backlight On (Transmissive Mode)	Luminance on TFT ( $I_f = 20\text{mA/LED}$ )	Lv	Normally viewing angle $\theta_x = \phi_y = 0^\circ$	320	400	-	cd/m <sup>2</sup>	
	Contrast ratio(See 7.3)	CR		-	(350)	-		
	Response time (See 7.2)	Tr+Tf		-	20	-	ms	
	Chromaticity Transmissive (See 7.5)	Red	X <sub>R</sub>	Center CR≥10	-	TBD	-	
			Y <sub>R</sub>		-	TBD	-	
		Green	X <sub>G</sub>		-	TBD	-	
			Y <sub>G</sub>		-	TBD	-	
		Blue	X <sub>B</sub>		-	TBD	-	
			Y <sub>B</sub>		-	TBD	-	
	White	X <sub>W</sub>	-	TBD	-			
Y <sub>W</sub>		-	TBD	-				
Viewing Angle (See 6.4)	Horizontal	$\theta_{x+}$	Center CR≥10	60	65	-	Deg.	
		$\theta_{x-}$		60	65	-		
	Vertical	$\phi_{y+}$		45	50	-		
		$\phi_{y-}$		55	60	-		
NTSC Ratio(Gamut)				-	50.4	-	%	

7.2. Definition of Response Time

7.2.1. Normally Black Type (Negative)

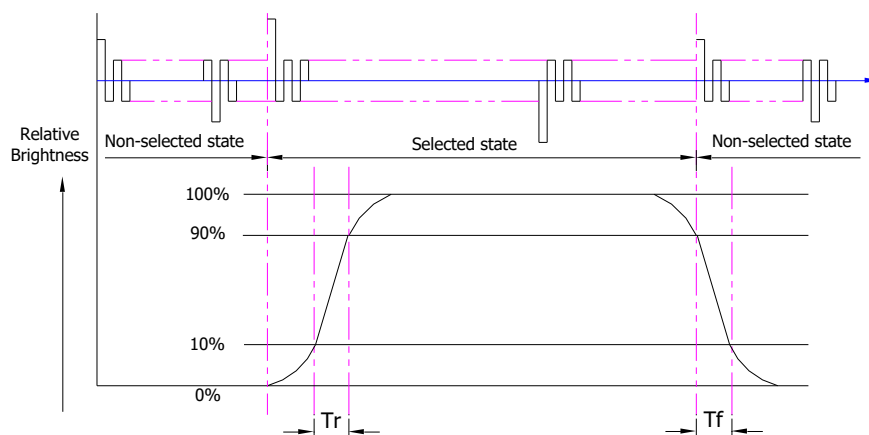

Tr is the time it takes to change from non-selected state with relative luminance 10% to selected state with relative luminance 90%;

Tf is the time it takes to change from selected state with relative luminance 90% to non-selected state with relative luminance 10%

Note: Measuring machine: LCD-5100

**7.2.2. Normally White Type (Positive)**

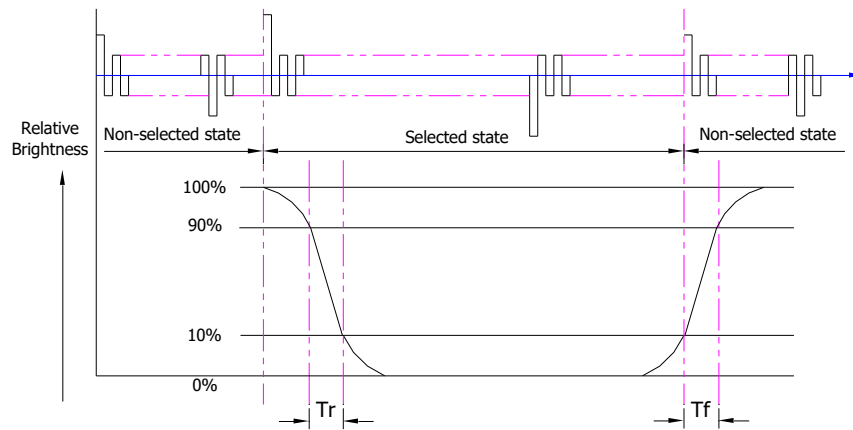

Tr is the time it takes to change from non-selected stage with relative luminance 90% to selected state with relative luminance 10%;

Tf is the time it takes to change from selected state with relative luminance 10% to non-selected state with relative luminance 90%;

Note: Measuring machine: LCD-5100 or EQUI

**7.3. Definition of Contrast Ratio**

Contrast is measured perpendicular to display surface in reflective and transmissive mode.

The measurement condition is:

Measuring Equipment	Eldim or Equivalent
Measuring Point Diameter	3mm//1mm
Measuring Point Location	Active Area centre point
Test pattern	A: All Pixels white
	B: All Pixel black
Contrast setting	Maximum

Definitions: CR (Contrast) = Luminance of White Pixel / Luminance of Black Pixel

**7.4. Definition of Viewing Angles**

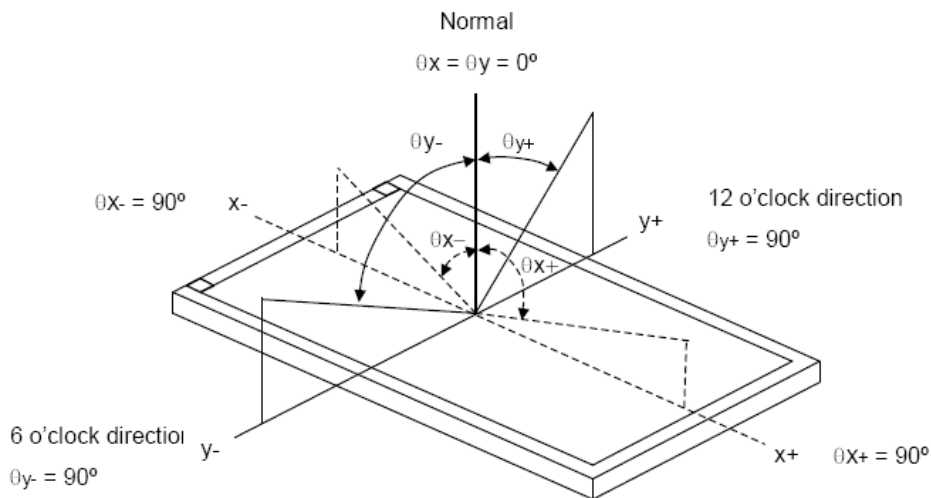

Measuring machine: LCD-5100 or EQUI



**7.5. Definition of Color Appearance**

R,G,B and W are defined by (x, y) on the IE chromaticity diagram

NTSC=area of RGB triangle/area of NTSC triangleX100%

Measuring picture: Red, Green, Blue and White (Measuring machine: BM-7)

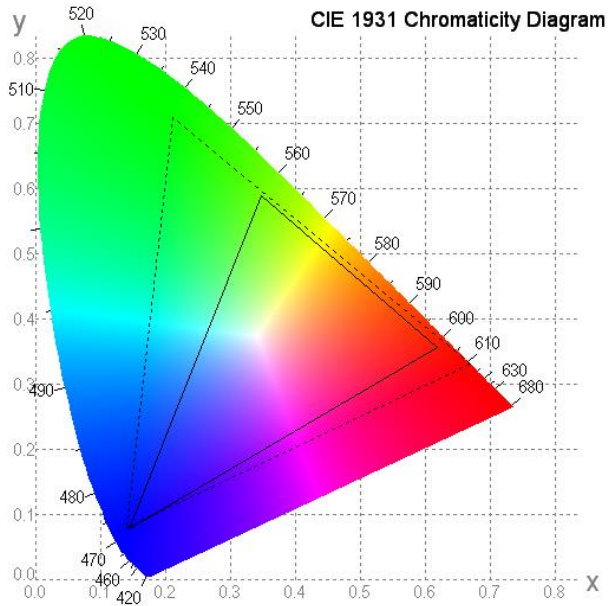

**7.6. Definition of Surface Luminance, Uniformity and Transmittance**

Using the transmissive mode measurement approach, measure the white screen luminance of the display panel and backlight.

7.6.1. Surface Luminance:  $L_v = \text{average} (L_{P1}:L_{P9})$

7.6.2. Uniformity =  $\text{Minimal} (L_{P1}:L_{P9}) / \text{Maximal} (L_{P1}:L_{P9}) * 100\%$

7.6.3. Transmittance =  $L_v \text{ on LCD} / L_v \text{ on Backlight} * 100\%$

Note: Measuring machine: BM-7

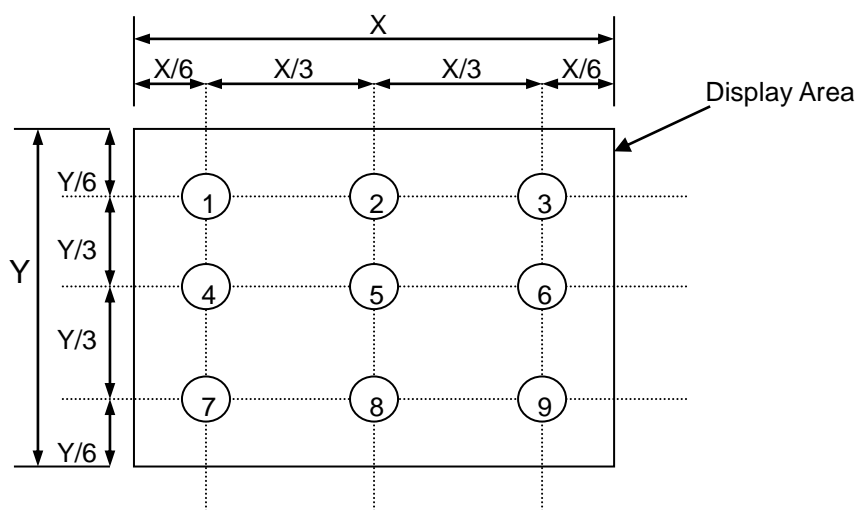

### 8. Block Diagram and Power Supply

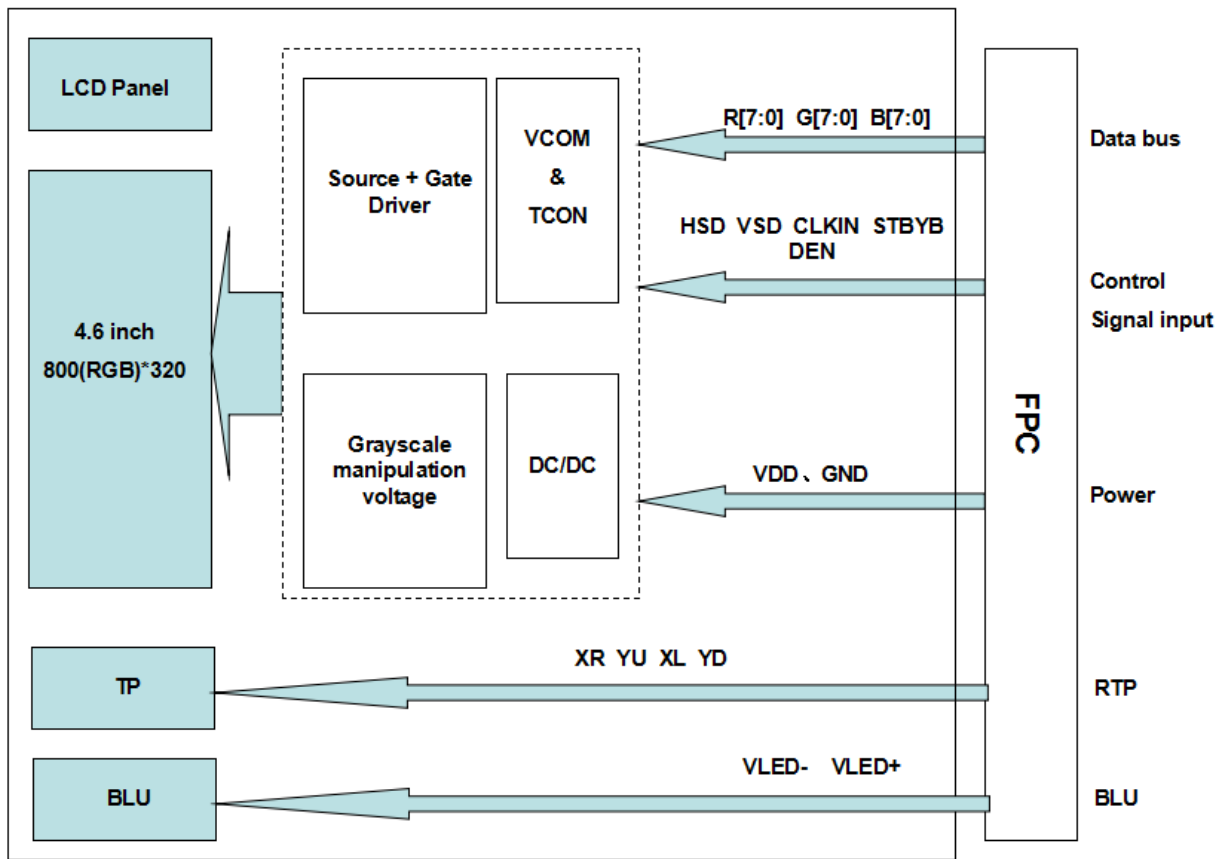

## 9. Interface Pins Definition

No.	Symbol	Function	Remark
1	VLED-	LED Input Terminal(Cathode)	
2	VLED+	LED Input Terminal(Anode)	
3	GND	Power voltage	
4	VDD	Power voltage	
5	R0	Red data(LSB)	
6	R1	Red data	
7	R2	Red data	
8	R3	Red data	
9	R4	Red data	
10	R5	Red data	
11	R6	Red data	
12	R7	Red data(MSB)	
13	G0	Green data(LSB)	
14	G1	Green data	
15	G2	Green data	
16	G3	Green data	
17	G4	Green data	
18	G5	Green data	
19	G6	Green data	
20	G7	Green data(MSB)	
21	B0	Blue data(LSB)	
22	B1	Blue data	
23	B2	Blue data	
24	B3	Blue data	
25	B4	Blue data	
26	B5	Blue data	
27	B6	Blue data	
28	B7	Blue data(MSB)	
29	GND	Ground	
30	CLKIN	Clock for input data. Data latched at rising edge of this signal	
31	STBYB	Display on/off	
32	HSD	Horizontal sync signal	
33	VSD	Vertical sync signal	
34	DEN	Data enable. (In SYNC mode this pin should not be used.)	
35	NC	No connection	
36	GND	Ground	
37	XR	Touch panel terminal.	
38	YD	Touch panel terminal.	
39	XL	Touch panel terminal.	
40	YU	Touch panel terminal.	

10. AC electrical characteristics

Parameter	Symbol	Min	Typ.	Max.	Unit	Conditions
VDD Power on Slew Rate	$T_{POR}$	-	-	20	ms	From 0V to 90% VDD
RSTB pulse width	$T_{RST}$	50	-	-	us	Clkin=50MHz
CLKIN cycle time	$T_{cph}$	20	-	-	ns	
CLKIN pulse duty	$T_{cwh}$	40	50	60	%	
VSD setup time	$T_{vst}$	8	-	-	ns	
VSD hold time	$T_{vhd}$	8	-	-	ns	
HSD setup time	$T_{hst}$	8	-	-	ns	
HSD hold time	$T_{hhd}$	8	-	-	ns	
Data setup time	$T_{dsu}$	8	-	-	ns	D[7:0], D1[7:0], D2[7:0] to clkin
Date hold time	$T_{dhd}$	8	-	-	ns	D[7:0], D1[7:0], D2[7:0] to clkin
DE setup time	$T_{esu}$	8	-	-	ns	
DE hold time	$T_{ehd}$	8	-	-	ns	
Output stable time	$T_{sst}$	-	-	6	us	10% to 90% target voltage. CL=120pF, R=10Kohm

10.1.Parallel 24-bit RGB Mode

Parameter	Symbol	Min	Typ.	Max.	Unit	Conditions
CLKIN Frequency	$F_{clk}$	-	40	50	MHz	VDD=2.7V~3.6V
CLKIN Cycle Time	$T_{clk}$	20	25	-	ns	
CLKIN Pulse Duty	$T_{cwh}$	40	50	60	%	Tclk
Time from HSD to Source Output	$T_{hso}$	-	64	-	CLKIN	
Time from HSD to LD	$T_{hld}$	-	64	-	CLKIN	
Time from HSD to STV	$T_{hstv}$	-	2	-	CLKIN	
Time from HSD to CKV	$T_{hckv}$	-	20	-	CLKIN	
Time from HSD to OEV	$T_{hoev}$	-	4	-	CLKIN	
LD pulse width	$T_{wld}$	-	10	-	CLKIN	
CKV pulse width	$T_{wckv}$	-	66	-	CLKIN	
OEV pulse width	$T_{woev}$	-	74	-	CLKIN	

10.2.Input Clock and Data Timing Diagram

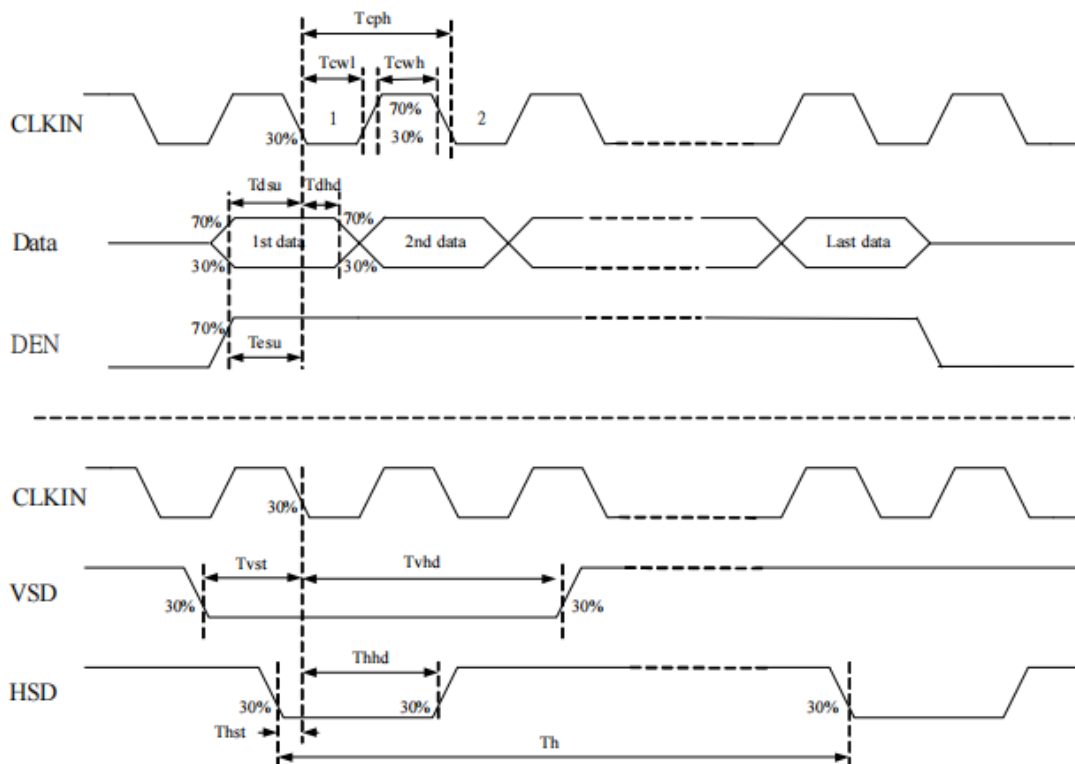

10.3. Power ON/OFF Sequence

In order to prevent IC from power on reset fail, the rising time (TPOR) of the digital power supply VDD should be maintained within the given specifications. Refer to "AC Characteristics" for more detail on timing.

Power-On/Off Timing Sequence

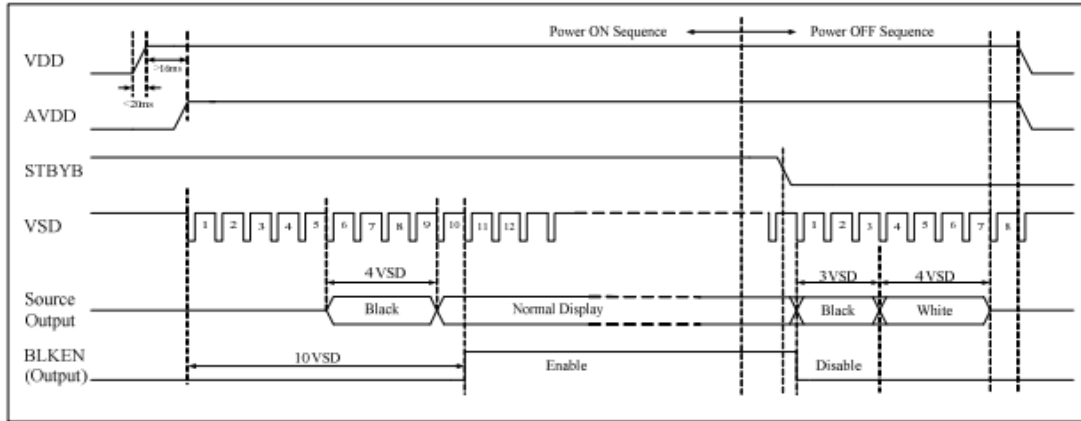

Standby Mode Sequence

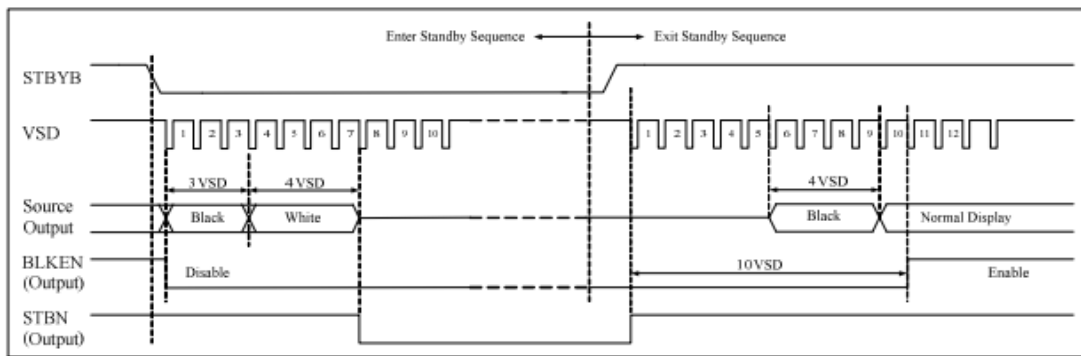

## **11. Quality Assurance**

### **11.1 Purpose**

This standard for Quality Assurance assures the quality of LCD module products supplied to customer.

### **11.2 Standard for Quality Test**

#### 11.2.1 Sampling Plan:

GB2828.1-2012

Single sampling, normal inspection

#### 11.2.2 Sampling Criteria:

Visual inspection: AQL 1.5

Electrical functional: AQL 0.65.

#### 11.2.3 Reliability Test:

Detailed requirement refer to Reliability Test Specification.

### **11.3 Nonconforming Analysis & Disposition**

#### 11.3.1 Nonconforming analysis:

11.3.1.1 Customer should provide overall information of non-conforming sample for their complaints.

11.3.1.2 After receipt of detailed information from customer, the analysis of nonconforming parts usually should be finished in one week.

11.3.1.3 If cannot finish the analysis on time, customer will be notified with the progress status.

#### 11.3.2 Disposition of nonconforming:

11.3.2.1 Non-conforming product over PPM level will be replaced.

11.3.2.2 The cause of non-conformance will be analyzed. Corrective action will be discussed and implemented.

### **11.4 Agreement Items**

Shall negotiate with customer if the following situation occurs:

11.4.1 There is any discrepancy in standard of quality assurance.

11.4.2 Additional requirement to be added in product specification.

11.4.3 Any other special problem.

### **11.5 Standard of the Product Visual Inspection**

#### 11.5.1 Appearance inspection:

11.5.1.1 The inspection must be under illumination about 1000 – 1500 lx, and the distance of view must be at 30cm ± 2cm.

11.5.1.2 The viewing angle should be 45° from the vertical line without reflection light or follows customer's viewing angle specifications.

11.5.1.3 Definition of area: A Zone: Active Area, B Zone: Viewing Area,

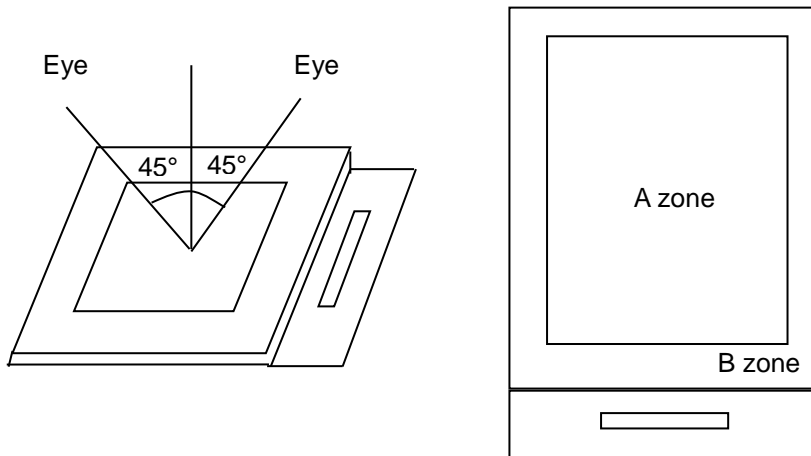

11.5.2 Basic principle:

11.5.2.1 A set of sample to indicate the limit of acceptable quality level must be discussed by both us and customer when there is any dispute happened.

11.5.2.2 New item must be added on time when it is necessary.

**11.6 Inspection Specification**

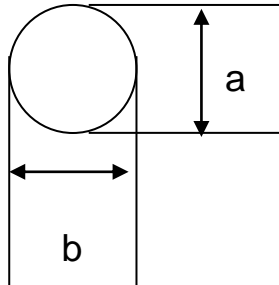
No.	Item	Criteria (Unit: mm)																		
01	Black / White spot Foreign material (Round type) Pinholes Stain Particles inside cell. (Minor defect)	 <table border="1" data-bbox="909 1048 1412 1393"> <thead> <tr> <th>Size</th> <th>Area</th> <th>Acc. Qty</th> </tr> </thead> <tbody> <tr> <td><math>\phi \leq 0.10</math></td> <td></td> <td>Ignore</td> </tr> <tr> <td><math>0.10 &lt; \phi \leq 0.15</math></td> <td></td> <td>2</td> </tr> <tr> <td><math>0.15 &lt; \phi \leq 0.25</math></td> <td></td> <td>1</td> </tr> <tr> <td><math>0.25 &lt; \phi</math></td> <td></td> <td>0</td> </tr> <tr> <td>Total</td> <td></td> <td>2 no include <math>\phi \leq 0.10</math></td> </tr> </tbody> </table> <p><math>\phi = (a + b) / 2</math> Distance between 2 defects should more than 5mm apart.</p>	Size	Area	Acc. Qty	$\phi \leq 0.10$		Ignore	$0.10 < \phi \leq 0.15$		2	$0.15 < \phi \leq 0.25$		1	$0.25 < \phi$		0	Total		2 no include $\phi \leq 0.10$
Size	Area	Acc. Qty																		
$\phi \leq 0.10$		Ignore																		
$0.10 < \phi \leq 0.15$		2																		
$0.15 < \phi \leq 0.25$		1																		
$0.25 < \phi$		0																		
Total		2 no include $\phi \leq 0.10$																		
02	Electrical Defect (Minor defect)	<table border="1" data-bbox="534 1518 1359 1733"> <thead> <tr> <th></th> <th>Display Area</th> <th>Total</th> <th rowspan="3">Note1</th> </tr> </thead> <tbody> <tr> <td>Bright dot</td> <td>0</td> <td>0</td> </tr> <tr> <td>Dark dot</td> <td><math>N \leq 2</math></td> <td><math>N \leq 2</math></td> </tr> <tr> <td>Total dot</td> <td><math>N \leq 2</math></td> <td><math>N \leq 2</math></td> <td></td> </tr> <tr> <td>Mura</td> <td colspan="2">Not visible through 5% ND filters.</td> <td>Note 2</td> </tr> </tbody> </table> <p>Remark: 1. Bright dot caused by scratch and foreign object accords to item 1.</p>		Display Area	Total	Note1	Bright dot	0	0	Dark dot	$N \leq 2$	$N \leq 2$	Total dot	$N \leq 2$	$N \leq 2$		Mura	Not visible through 5% ND filters.		Note 2
	Display Area	Total	Note1																	
Bright dot	0	0																		
Dark dot	$N \leq 2$	$N \leq 2$																		
Total dot	$N \leq 2$	$N \leq 2$																		
Mura	Not visible through 5% ND filters.		Note 2																	

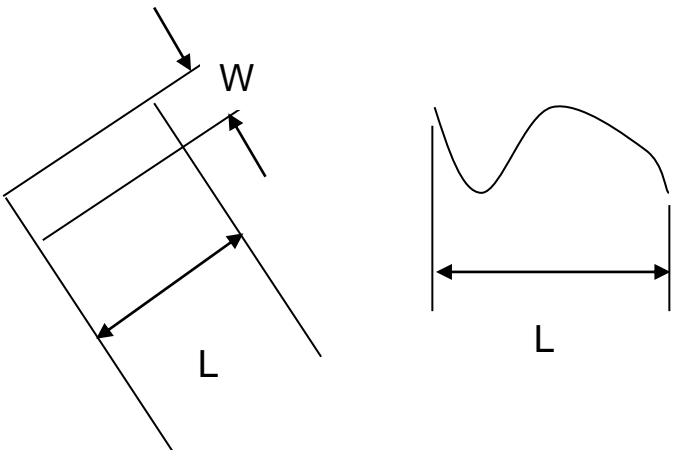
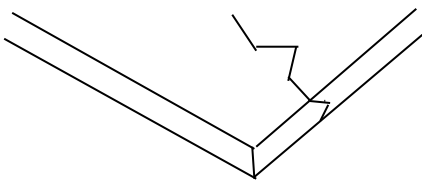
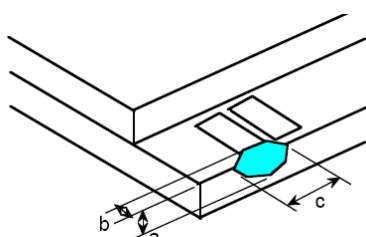
<p>03</p>	<p>Black and White line Scratch Foreign material (Line type) (Minor defect)</p>	 <table border="1" data-bbox="598 761 1220 1019"> <thead> <tr> <th>Length</th> <th>Width</th> <th>Acc. Qty</th> </tr> </thead> <tbody> <tr> <td>/</td> <td><math>W \leq 0.1</math></td> <td>Ignore</td> </tr> <tr> <td><math>L \leq 2.5</math></td> <td><math>0.1 &lt; W \leq 0.2</math></td> <td>3</td> </tr> <tr> <td><math>L &gt; 2.5</math></td> <td><math>0.2 &lt; W</math></td> <td>0</td> </tr> <tr> <td colspan="2">Total</td> <td>3</td> </tr> </tbody> </table> <p>Distance between 2 defects should more than 3mm apart. Scratches not viewable through the back of the display are acceptable.</p>	Length	Width	Acc. Qty	/	$W \leq 0.1$	Ignore	$L \leq 2.5$	$0.1 < W \leq 0.2$	3	$L > 2.5$	$0.2 < W$	0	Total		3
Length	Width	Acc. Qty															
/	$W \leq 0.1$	Ignore															
$L \leq 2.5$	$0.1 < W \leq 0.2$	3															
$L > 2.5$	$0.2 < W$	0															
Total		3															
<p>04</p>	<p>Glass Crack (Minor defect)</p>	 <p>Crack is potential to enlarge, any type is not allowed.</p>															
<p>05</p>	<p>Glass Chipping Pad Area: (Minor defect)</p> 	<table border="1" data-bbox="861 1635 1332 1803"> <thead> <tr> <th>Length and Width</th> <th>Acc. Qty</th> </tr> </thead> <tbody> <tr> <td><math>c &gt; 3.0, b &lt; 1.0</math></td> <td>1</td> </tr> <tr> <td><math>c &lt; 3.0, b &lt; 1.0</math></td> <td>3</td> </tr> <tr> <td colspan="2"><math>a &lt; \text{Glass Thickness}</math></td> </tr> </tbody> </table>	Length and Width	Acc. Qty	$c > 3.0, b < 1.0$	1	$c < 3.0, b < 1.0$	3	$a < \text{Glass Thickness}$								
Length and Width	Acc. Qty																
$c > 3.0, b < 1.0$	1																
$c < 3.0, b < 1.0$	3																
$a < \text{Glass Thickness}$																	

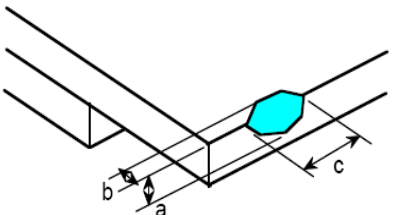
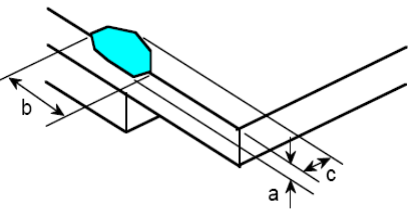
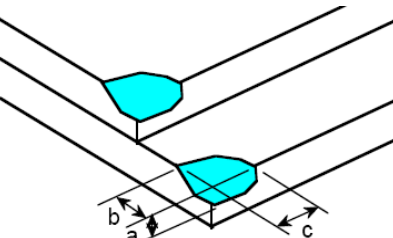
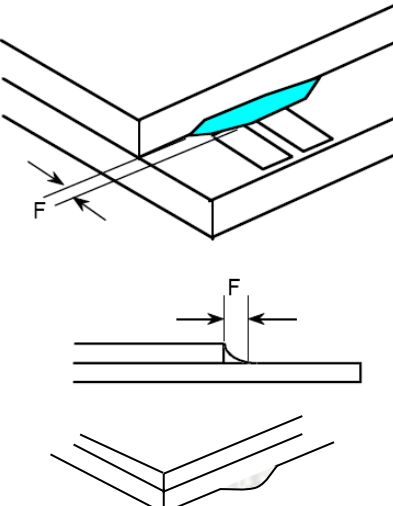

<p>06</p>	<p>Glass Chipping Rear of Pad Area: (Minor defect)</p> 	<table border="1"> <thead> <tr> <th>Length and Width</th> <th>Acc. Qty</th> </tr> </thead> <tbody> <tr> <td><math>c &gt; 3.0, b &lt; 1.0</math></td> <td>1</td> </tr> <tr> <td><math>c &lt; 3.0, b &lt; 1.0</math></td> <td>2</td> </tr> <tr> <td><math>c &lt; 3.0, b &lt; 0.5</math></td> <td>4</td> </tr> <tr> <td colspan="2" style="text-align: center;"><math>a &lt; \text{Glass Thickness}</math></td> </tr> </tbody> </table>	Length and Width	Acc. Qty	$c > 3.0, b < 1.0$	1	$c < 3.0, b < 1.0$	2	$c < 3.0, b < 0.5$	4	$a < \text{Glass Thickness}$	
Length and Width	Acc. Qty											
$c > 3.0, b < 1.0$	1											
$c < 3.0, b < 1.0$	2											
$c < 3.0, b < 0.5$	4											
$a < \text{Glass Thickness}$												
<p>07</p>	<p>Glass Chipping Except Pad Area: (Minor defect)</p> 	<table border="1"> <thead> <tr> <th>Length and Width</th> <th>Acc. Qty</th> </tr> </thead> <tbody> <tr> <td><math>c &gt; 3.0, b &lt; 1.0</math></td> <td>1</td> </tr> <tr> <td><math>c &lt; 3.0, b &lt; 1.0</math></td> <td>2</td> </tr> <tr> <td><math>c &lt; 3.0, b &lt; 0.5</math></td> <td>4</td> </tr> <tr> <td colspan="2" style="text-align: center;"><math>a &lt; \text{Glass Thickness}</math></td> </tr> </tbody> </table>	Length and Width	Acc. Qty	$c > 3.0, b < 1.0$	1	$c < 3.0, b < 1.0$	2	$c < 3.0, b < 0.5$	4	$a < \text{Glass Thickness}$	
Length and Width	Acc. Qty											
$c > 3.0, b < 1.0$	1											
$c < 3.0, b < 1.0$	2											
$c < 3.0, b < 0.5$	4											
$a < \text{Glass Thickness}$												
<p>08</p>	<p>Glass Corner Chipping: (Minor defect)</p> 	<table border="1"> <thead> <tr> <th>Length and Width</th> <th>Acc. Qty</th> </tr> </thead> <tbody> <tr> <td><math>c &lt; 3.0, b &lt; 3.0</math></td> <td>Ignore</td> </tr> <tr> <td colspan="2" style="text-align: center;"><math>a &lt; \text{Glass Thickness}</math></td> </tr> </tbody> </table>	Length and Width	Acc. Qty	$c < 3.0, b < 3.0$	Ignore	$a < \text{Glass Thickness}$					
Length and Width	Acc. Qty											
$c < 3.0, b < 3.0$	Ignore											
$a < \text{Glass Thickness}$												
<p>9</p>	<p>Glass Burr: (Minor defect)</p> 	<table border="1"> <thead> <tr> <th>Length</th> <th>Acc. Qty</th> </tr> </thead> <tbody> <tr> <td><math>F &lt; 1.0</math></td> <td>Ignore</td> </tr> </tbody> </table> <p>Glass burr don't affect assemble and module dimension.</p>	Length	Acc. Qty	$F < 1.0$	Ignore						
Length	Acc. Qty											
$F < 1.0$	Ignore											

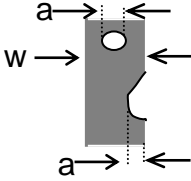
10	<p>FPC Defect: (Minor defect)</p> 	<p>10.1 Dent, pinhole width <math>a &lt; w/3</math>. (w: circuitry width.) 10.2 Open circuit is unacceptable. 10.3 No oxidation, contamination and distortion.</p>								
11	<p>Bubble on Polarizer (Minor defect)</p>	<table border="1"> <thead> <tr> <th>Diameter</th> <th>Acc. Qty</th> </tr> </thead> <tbody> <tr> <td><math>\varphi \leq 0.30</math></td> <td>Ignore</td> </tr> <tr> <td><math>0.30 &lt; \varphi \leq 0.50</math></td> <td><math>N \leq 2</math></td> </tr> <tr> <td><math>0.50 &lt; \varphi</math></td> <td><math>N = 0</math></td> </tr> </tbody> </table>	Diameter	Acc. Qty	$\varphi \leq 0.30$	Ignore	$0.30 < \varphi \leq 0.50$	$N \leq 2$	$0.50 < \varphi$	$N = 0$
Diameter	Acc. Qty									
$\varphi \leq 0.30$	Ignore									
$0.30 < \varphi \leq 0.50$	$N \leq 2$									
$0.50 < \varphi$	$N = 0$									
12	<p>Dent on Polarizer (Minor defect)</p>	<table border="1"> <thead> <tr> <th>Diameter</th> <th>Acc. Qty</th> </tr> </thead> <tbody> <tr> <td><math>\varphi \leq 0.25</math></td> <td>Ignore</td> </tr> <tr> <td><math>0.25 &lt; \varphi \leq 0.50</math></td> <td><math>N \leq 4</math></td> </tr> <tr> <td><math>0.50 &lt; \varphi</math></td> <td>None</td> </tr> </tbody> </table>	Diameter	Acc. Qty	$\varphi \leq 0.25$	Ignore	$0.25 < \varphi \leq 0.50$	$N \leq 4$	$0.50 < \varphi$	None
Diameter	Acc. Qty									
$\varphi \leq 0.25$	Ignore									
$0.25 < \varphi \leq 0.50$	$N \leq 4$									
$0.50 < \varphi$	None									
13	<p>Bezel</p>	<p>13.1 No rust, distortion on the Bezel. 13.2 No visible fingerprints, stains or other contamination.</p>								
14	<p>Touch Panel</p>	<p>D: Diameter W: width L: length 14.1 Spot: <math>D &lt; 0.25</math> is acceptable <math>0.25 \leq D \leq 0.4</math> 2dots are acceptable and the distance between defects should more than 10 mm. <math>D &gt; 0.4</math> is unacceptable 14.2 Dent: <math>D &gt; 0.40</math> is unacceptable 14.3 Scratch: <math>W \leq 0.03</math>, <math>L \leq 10</math> is acceptable, <math>0.03 &lt; W \leq 0.10</math>, <math>L \leq 10</math> is acceptable Distance between 2 defects should more than 10 mm. <math>W &gt; 0.10</math> is unacceptable.</p>								
15	<p>LCD Ripple</p>	<p>Touch the touch panel, cannot see the LCD ripple. Pen: R 0.8mm silicon rubber. Operation Force: TBD g</p>								
16	<p>PCB</p>	<p>16.1 No distortion or contamination on PCB terminals. 16.2 All components on PCB must same as documented on the BOM/component layout. 16.3 Follow IPC-A-600F.</p>								
17	<p>Soldering</p>	<p>Follow IPC-A-610C standard</p>								

18	Electrical Defect (Major defect)	<p>The below defects must be rejected.</p> <p>18.1 Missing vertical / horizontal segment,                  18.2 Abnormal Display.                  18.3 No function or no display.                  18.4 Current exceeds product specifications.                  18.5 LCD viewing angle defect.                  18.6 No Backlight.                  18.7 Dark Backlight.                  18.8 Touch Panel no function.</p>
----	-------------------------------------	---

Remark: LCD Panel Broken shall be rejected. Defect out of LCD viewing area is acceptable.

**11.7 Classification of Defects**

11.7.1 Visual defects (Except no / wrong label) are treated as minor defect and electrical defect is major.

11.7.2 Two minor defects are equal to one major in lot sampling inspection.

**11.8 Identification/marketing criteria**

Any unit with illegible / wrong /double or no marking/ label shall be rejected.

**11.9 Packing**

11.9.1 There should be no damage of the outside carton box, each packaging box should have one identical label.

11.9.2 Modules inside package box should have compliant mark.

11.9.3 All direct package materials shall offer ESD protection

**Note1:** Bright dot is defined as the defective area of the dot is larger than 50% of one sub-pixel area.

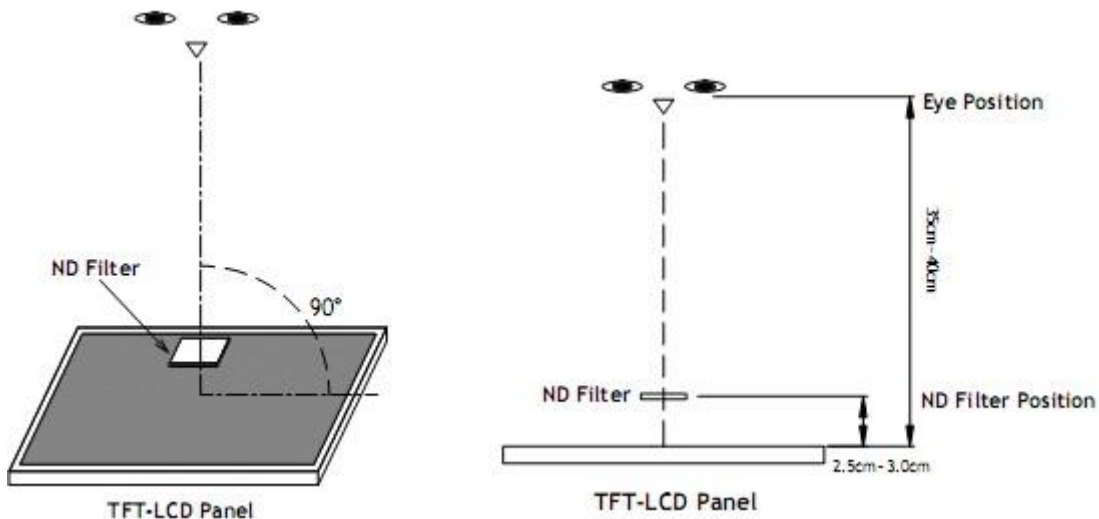

Bright dot: The bright dot size defect at black display pattern. It can be recognized by 2% transparency of filter when the distance between eyes and panel is 350mm ± 50mm.

Dark dot: Cyan, Magenta or Yellow dot size defect at white display pattern. It can be recognized by 5% transparency of filter when the distance between eyes and panel is 350mm ± 50mm.

**Note2:** Mura on display which appears darker / brighter against background brightness on parts of display area.

**12. Reliability Specification**

No	Item	Condition	Quantity	Criteria
1	High Temperature Operating	70°C, 96Hrs	2	GB/T2423.2-2008
2	Low Temperature Operating	-20°C, 96Hrs	2	GB/T2423.1-2008
3	High Humidity Operating	50°C, 90%RH, 96Hrs	2	GB/T2423.3-2016
4	High Temperature Storage	80°C, 96Hrs	2	GB/T2423.2-2008
5	Low Temperature Storage	-30°C, 96Hrs	2	GB/T2423.1-2008
6	Thermal Cycling Test	-20°C, 60min~70°C, 60min, 20 cycles.	2	GB/T2423.22-2012
7	Packing vibration	Frequency range:10Hz~50Hz Acceleration of gravity:5G X, Y, Z 30 min for each direction.	-	GB/T5170.14-2009
8	Electrical Static Discharge	Air: ±8KV 150pF/330 Ω 5 times Contact: ±4KV 150pF/330 Ω 5 times	2	GB/T17626.2-2018
9	Drop Test (Packaged)	Height:80 cm,1 corner, 3 edges, 6 surfaces.	-	GB/T2423.8-2018

Note1. No deflection cosmetic and operational function allowable.

Note2. Total current Consumption should be below double of initial value

**13. Precautions and Warranty**

**13.1.Safety**

- 13.1.1 The liquid crystal in the LCD is poisonous. Do not put it in your mouth. If the liquid crystal touches your skin or clothes, wash it off immediately using soap and water.
- 13.1.2 Since the liquid crystal cells are made of glass, do not apply strong impact on them. Handle with care.

**13.2.Handling**

- 13.2.1 Reverse and use within ratings in order to keep performance and prevent damage.
- 13.2.2 Do not wipe the polarizer with dry cloth, as it might cause scratch. If the surface of the LCD needs to be cleaned, wipe it swiftly with cotton or other soft cloth soaked with petroleum IPA, do not use other chemicals.

**13.3.Storage**

- 13.3.1. Do not store the LCD module beyond the specified temperature ranges.
- 13.3.2. Strong light exposure causes degradation of polarizer and color filter

**13.4.13.4 Metal Pin (Apply to Products with Metal Pins)**

13.4.1 Pins of LCD and Backlight

- 13.4.1.1 Solder tip can touch and press on the tip of Pin LEAD during the soldering

13.4.1.2 Recommended Soldering Conditions

Solder Type: Sn96.3~94-Ag3.3~4.3-Cu0.4~1.1

Maximum Solder Temperature: 370°C

Maximum Solder Time: 3s at the maximum temperature

Recommended Soldering Temp: 350±20°C

Typical Soldering Time: ≤3s

13.4.1.3 Solder Wetting

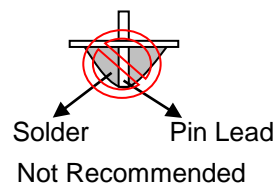
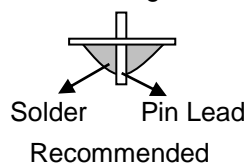

13.4.2 Pins of EL

- 13.4.2.1 Solder tip can touch and press on the tip of EL leads during soldering.
- 13.4.2.2 No Solder Paste on the soldering pad on the motherboard is recommended.

13.4.2.3 Recommended Soldering Conditions

Solder type: Nippon Alimit Leadfree SR-34, size 0.5mm

Recommended Solder Temperature: 270~290°C

Typical Soldering Time: ≤2s

Minimum solder distance from EL lamp (body):2.0mm

- 13.4.2.4 No horizontal press on the EL leads during soldering.

- 13.4.2.5 180° bend EL leads three times is not allowed.

13.4.2.6 Solder Wetting

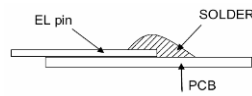

Recommended

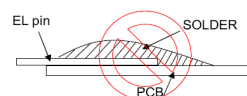

Not Recommended

13.4.2.7 The type of the solder iron:

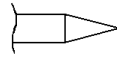

Recommended

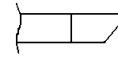

Not Recommended

13.4.2.8 Solder Pad

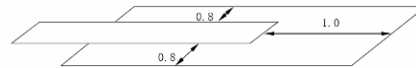

**13.5.Operation**

- 13.5.1. Do not drive LCD with DC voltage
- 13.5.2. Response time will increase below lower temperature
- 13.5.3. Display may change color with different temperature
- 13.5.4. Mechanical disturbance during operation, such as pressing on the display area, may cause the segments to appear “fractured”.
- 13.5.5. Do not connect or disconnect the LCM to or from the system when power is on.
- 13.5.6. Never use the LCM under abnormal condition of high temperature and high humidity.
- 13.5.7. Module has high frequency circuits. Sufficient suppression to the electromagnetic interface shall be done by system manufacturers. Grounding and shielding methods may be important to minimize the interference.
- 13.5.8. Do not display the fixed pattern for long time (we suggest the time not longer than one hour) because it may develop image sticking due to the TFT structure

**13.6.Static Electricity**

- 13.6.1 CMOS LSIs are equipped in this unit, so care must be taken to avoid the electro-static charge, by ground human body, etc.
- 13.6.2 The normal static prevention measures should be observed for work clothes and benches.
- 13.6.3 The module should be kept into anti-static bags or other containers resistant to static for storage.

**13.7.Limited Warranty**

- 13.7.1 Our warranty liability is limited to repair and/or replacement. We will not be responsible for any consequential loss.
- 13.7.2 If possible, we suggest customer to use up all modules in six months. If the module storage time over twelve months, we suggest that recheck it before the module be used.
- 13.7.3 After the product shipped, any product quality issues must be feedback within three months, otherwise, we will not be responsible for the subsequent or consequential events.

14. Outline Drawing

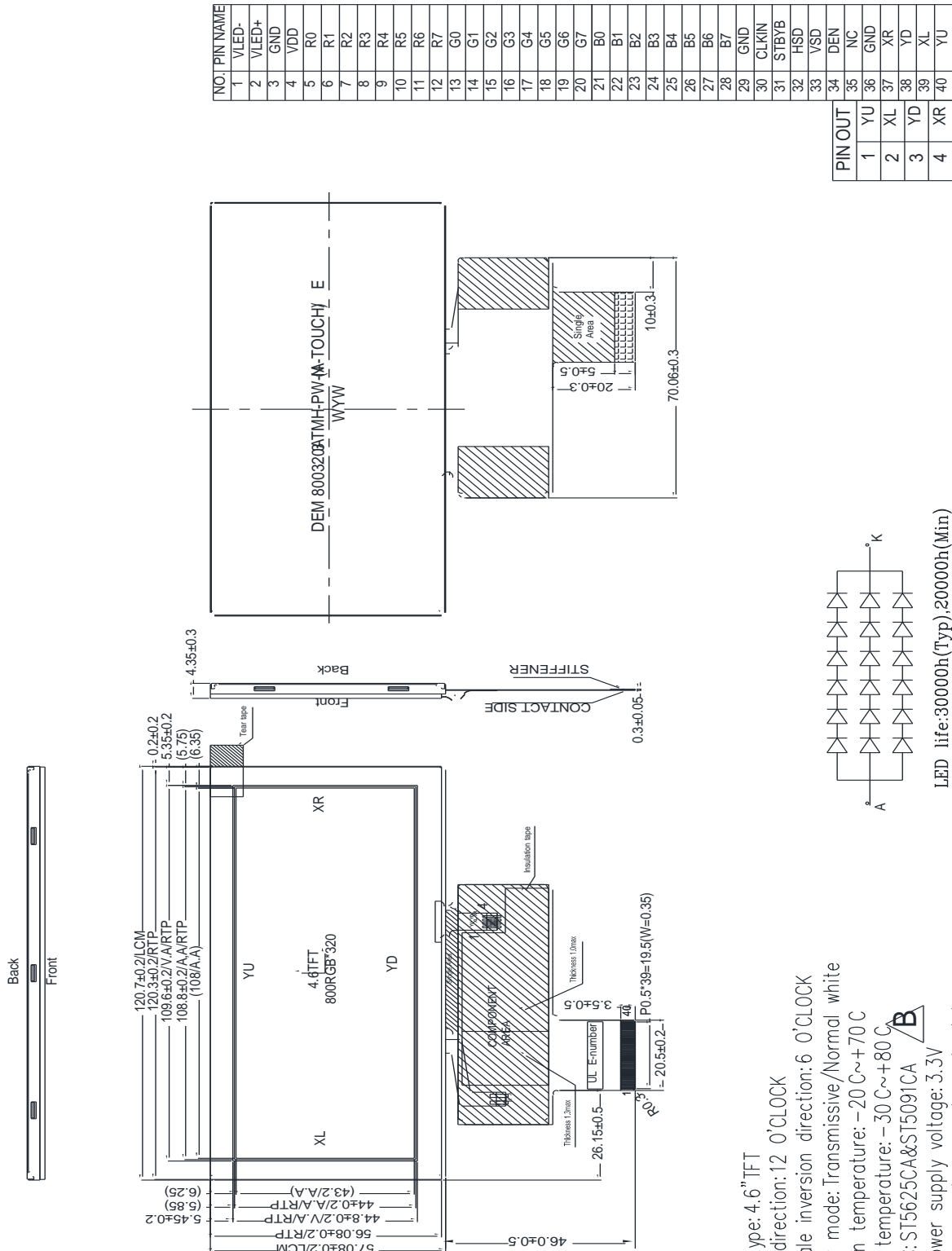

- NOTES:
1. Display type: 4.6" TFT
  2. Viewing direction: 12 O'CLOCK
  3. Gary scale inversion direction: 6 O'CLOCK
  4. Polarizer mode: Transmissive/Normal white
  5. Operation temperature: -20 C~+70 C
  6. Storage temperature: -30 C~+80 C
  7. Driver IC: ST5625CA&ST5091CA
  8. Logic power supply voltage: 3.3V
  9. Backlight: White/18 LEDs/19.2V(typ)/60mA  
Brightness: 400(TYP)cd/m<sup>2</sup>
  10. ROHS must be complied
  11. Unspecification tolerance are ±0.2