

WPEQ-257ACN

802.11ac/abgn Dual-Band
2T2R Half Mini PCIe Module



Next-Generation High Throughput Enterprise Networking Solution

The WPEQ-257ACN is powered by Qualcomm Atheros QCA9882 radio chip and features 2x2 11ac technology for higher throughput performance, reliability and range. It is designed to meet the demanding performance requirements of critical embedded applications.

The WPEQ-257ACN dramatically increase the overall throughput up to 867Mbps. Leveraging the revolutionary 11ac technology, PEQ-257ACN sets a new benchmark in throughput and range, making it ideal for consumer and enterprise applications, such as point of sale, gaming machine and medical equipment. The WPEQ-257ACN is backward compatible with 802.11a/b/g/n and fully supports industry standards compliant security.

Embedded Application :

Applications include medical devices, security systems, industrial, Point of Sale, digital signs, industrial tablet PC's, handheld devices, thin client devices, Gaming machine, medical equipment, Robotic ,warehouse,etc.

Key Feature :

- Qualcomm Atheros QCA9882
- Antenna: U.FL * 2 for 2T2R
- Data Rates: allows link speeds up to 867Mbps.
- Support Linux driver
- 802.11ac compliant & backward compatible with 802.11a/b/g/n

Specification :

Standards:	IEEE 802.11ac/a/b/g/n (2T2R)
Chipset:	Qualcomm Atheros QCA9882-BR4A
Data Rate:	802.11b: 11Mbps / 802.11a/g: 54Mbps / 802.11n: MCS0 ~ 15/ 802.11ac: MCS0 ~ 9
Operating Frequency:	IEEE 802.11 ac/a/b/g/n ISM Band, 2.412GHz ~ 2.472GHz, 5.180MHz ~ 5.825MHz *Subject to local regulations
Interface:	Mini PCI Express
Form Factor:	Half Mini PCI-e
Antenna:	2 x UFL connector for 2T2R
Modulation:	802.11b: DSSS (DBPSK, DQPSK, CCK) 802.11a/g: OFDM (BPSK, QPSK, 16-QAM, 64-QAM) 802.11n: OFDM (BPSK, QPSK, 16-QAM, 64-QAM) 802.11ac: OFDM (BPSK, QPSK, 16-QAM, 64-QAM, 256-QAM)
Power consumption	TX: 700mA / RX: 300mA
Operating Voltage:	DC 3.3V
Temperature Range:	-20°C to +60°C (Operating) / -30°C to +75°C (Storage)
Humidity (Non-Condensing)	Operating Humidity (non-condensing): 10% ~ 85% Storage Humidity (non-condensing): 5% ~ 90%
Dimension (in mm):	29.85 x 26.8 x 2.05 mm
Weight (g):	≤ 4.7g
Driver Support:	Linux
Security	64/128-bits WEP, WPA, WPA2, 802.1x

OUTPUT POWER & SENSITIVITY		
802.11b		
Data Rate	Tx \pm 2dBm	Rx Sensitivity
11Mbps	15dBm	\leq -76dBm

OUTPUT POWER & SENSITIVITY		
802.11g		
Data Rate	Tx \pm 2dBm	Rx Sensitivity
54Mbps	13dBm	\leq -65dBm

802.11n / 2.4GHz				
	Data Rate	Tx \pm 2dBm (1TX)	Tx \pm 2dBm (2TX)	Rx Sensitivity
HT20	MCS7	12dBm	15dBm	\leq - 64dBm
	MCS7	11dBm	14dBm	\leq - 61dBm
HT40	MCS7	11dBm	14dBm	\leq - 61dBm

802.11a		
Data Rate	Tx \pm 2dBm	Rx Sensitivity
54Mbps	12dBm	\leq -65dBm

802.11n / 5GHz				
	Data Rate	Tx \pm 2dBm (1TX)	Tx \pm 2dBm (2TX)	Rx Sensitivity
HT20	MCS7	11dBm	14dBm	\leq - 64dBm
	MCS7	10dBm	13dBm	\leq - 61dBm
HT40	MCS7	10dBm	13dBm	\leq - 61dBm

802.11ac				
	Data Rate	Tx \pm 2dBm (1TX)	Tx \pm 2dBm (2TX)	Rx Sensitivity
VHT80	MCS9	4dBm	7dBm	\leq - 51dBm
	MCS9	4dBm	7dBm	\leq - 51dBm

Block Diagram

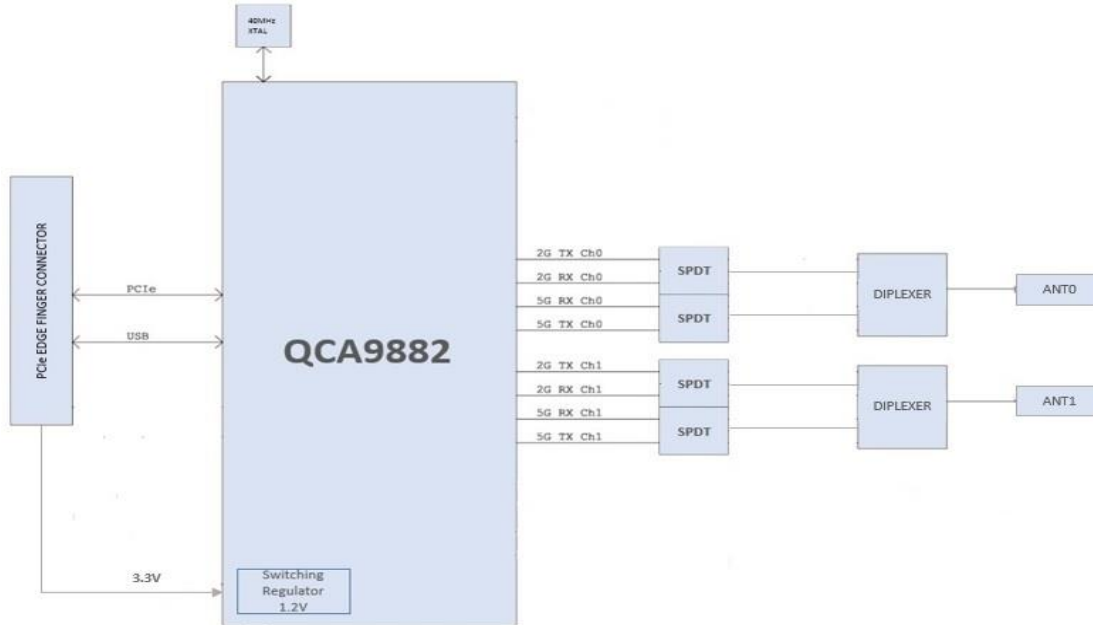

Mechanical Dimension (mm)

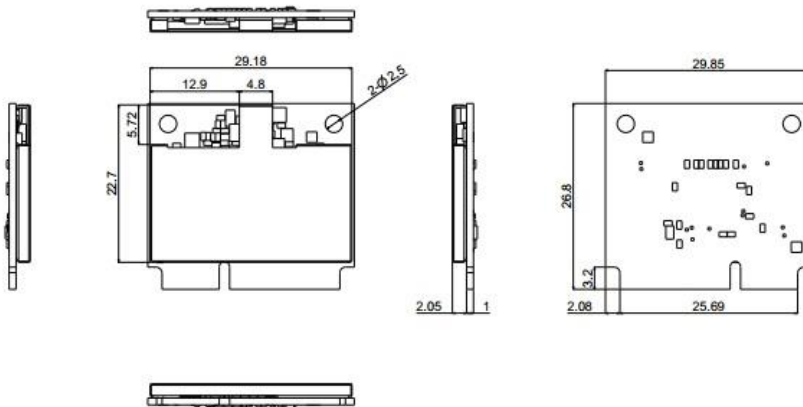

Pin Assignment

Pin#	Pin Name	Description	Pin#	Pin Name	Description
1	WAKE_L(NA)	Output and open Drain active Low signal. This signal is used to request that the system return from a sleep/suspended state to service a function initiated wake event.	2	+3.3V	+3.3V
3	No Connection	-	4	GND	GND
5	No Connection	-	6	No Connection	-
7	CLKREQ_L	Output for reference clock request signal	8	No Connection	-
9	GND	GND	10	No Connection	-
11	REFCLK-	Input signal for PCI Express differential reference clock (100 MHz)	12	No Connection	-
13	REFCLK+	Input signal for PCI Express differential reference clock (100 MHz)	14	No Connection	-
15	GND	GND	16	No Connection	-
17	No Connection	-	18	GND	GND
19	No Connection	-	20	W_DISABLE_L	Input and active low signal. This signal is used by the system to disable radio operation on add-in cards that implement radio frequency applications. When implemented, this signal requires a pull-up resistor on the card
21	GND	GND	22	PERST_L	Input signal for functional reset to the card

Pin Assignment

Pin#	Pin Name	Description	Pin#	Pin Name	Description
23	PERn0	PCI Express x1 data interface: one differential receive pair	24	+3.3V	+3.3V
25	PERp0	PCI Express x1 data interface: one differential receive pair	26	GND	GND
27	GND	GND	28	No Connection	-
29	GND	GND	30	No Connection	-
31	PETn0	PCI Express x1 data interface: one differential transmit pair	32	No Connection	-
33	PETp0	PCI Express x1 data interface: one differential transmit pair	34	GND	GND
35	GND	GND	36	No Connection	-
37	GND	GND	38	No Connection	-
39	No Connection	-	40	GND	GND
41	No Connection	-	42	No Connection	-
43	GND	GND	44	LED_WLAN_L (OPT)	Output and open drain active low signal. This signal is used to allow the PCI Express Mini Card add-in card to provide status indicators via LED devices that will be provided by the system
45	No Connection	-	46	No Connection	-
47	No Connection	-	48	No Connection	-
49	No Connection	-	50	GND	GND
51	No Connection	-	52	+3.3V	+3.3V
35	GND	GND	36	No Connection	-
37	GND	GND	38	No Connection	-
39	No Connection	-	40	GND	GND
41	No Connection	-	42	No Connection	-
43	GND	GND	44	LED_WLAN_L	Output and open drain active

				(OPT)	low signal. This signal is used to allow the PCI Express Mini Card add-in card to provide status indicators via LED devices that will be provided by the system
45	No Connection	-	46	No Connection	-
47	No Connection	-	48	No Connection	-
49	No Connection	-	50	GND	GND
51	No Connection	-	52	+3.3V	+3.3V

*NA→No active, OPT →Optional