

TOP VIEW

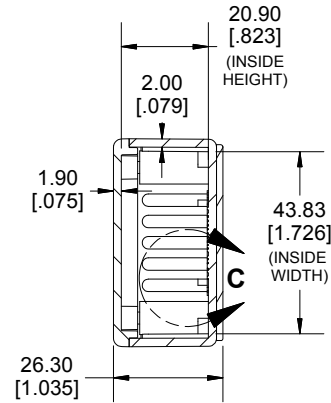

SECTION A-A

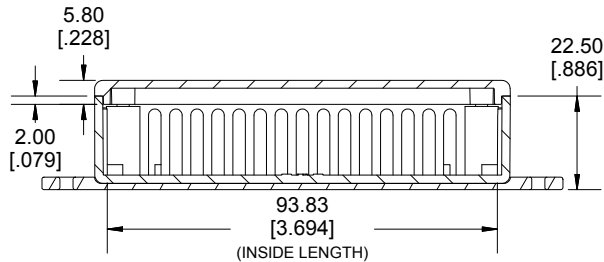
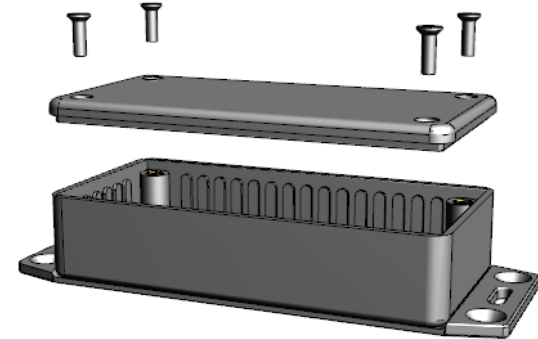

SECTION B-B  
SIDE VIEW

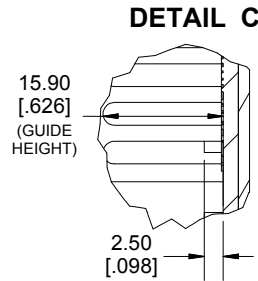

DETAIL C

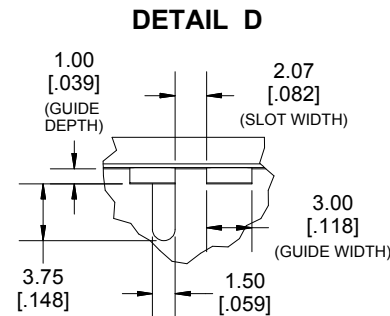

DETAIL D

Enclosures can be Factory Modified ( Milling, Drilling, Printing etc.)  
Contact Factory [mjm@hammondmfg.com](mailto:mjm@hammondmfg.com) for quotes  
Solid models of this enclosure available in STEP or IGES.

**NOTE**

Purchased assembly includes box, lid, 4 cover screws, and pre installed brass inserts.  
Enclosure made from FRABS

**Recommended Torque: 42-57 ozf.in (30-40 cN.m)**

**PART NUMBERS**

**1591A Enlosure**

Flame Retardant ABS Black	1591AF2BK
Flame Retardant ABS Grey	1591AF2GY

**Accessories**

Plated Cover screw M3 - 0.5 X 10mm (100Pkg)	1591MS100 (Silver)
	1591MS100BK (Black)
PC Board Card Adapters	1591Z6 (6Pkg)
	1591Z50 (50 Pkg)
	1591Z100 (100Pkg)
Nylon Belt / Pocket clip	1599CLIP (Black)
	1599CLIPGY (Grey)
Clear Lids - Flame Retardant Polycarbonate - Lid ONLY	1591AC

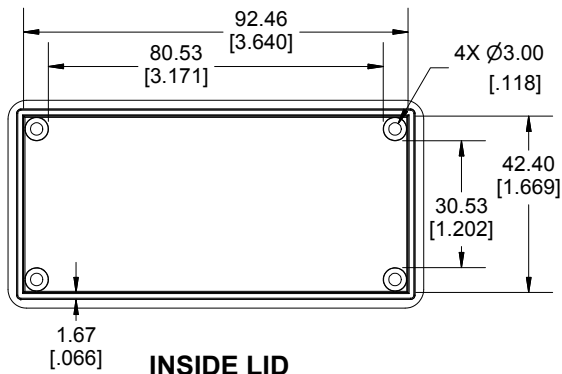

INSIDE LID

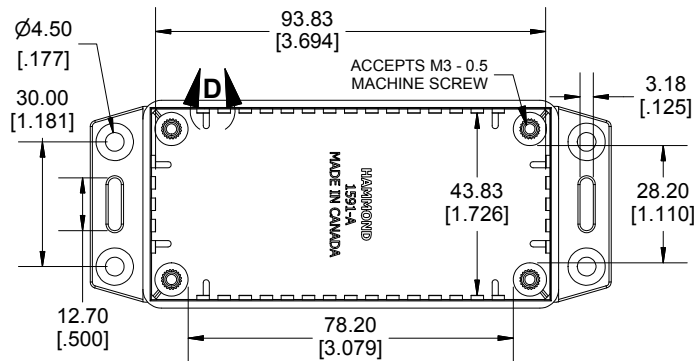

INSIDE BOX

Dimensions:  
mm  
[inches]

**HAMMOND  
MANUFACTURING®**  
**1591AF2**  
[www.hammondmfg.com](http://www.hammondmfg.com)