

[Products](#)[ioModule](#)[W5100S-io](#)

# W5100S-io

## Overview

W5100S-io is a compact size network module that includes a W5100S (TCP/IP hardwired chip and PHY embedded).It can be used as a component and no effort is required to interface W5100S. The W5100S-io an ideal option for users who want to develop their Internet enabling systems rapidly. W5100S-io is hardware compatible with W5500-io and W6100-io.

For the detailed information on implementation of Hardware TCP/IP, refer to the [W5100S Datasheet](#).

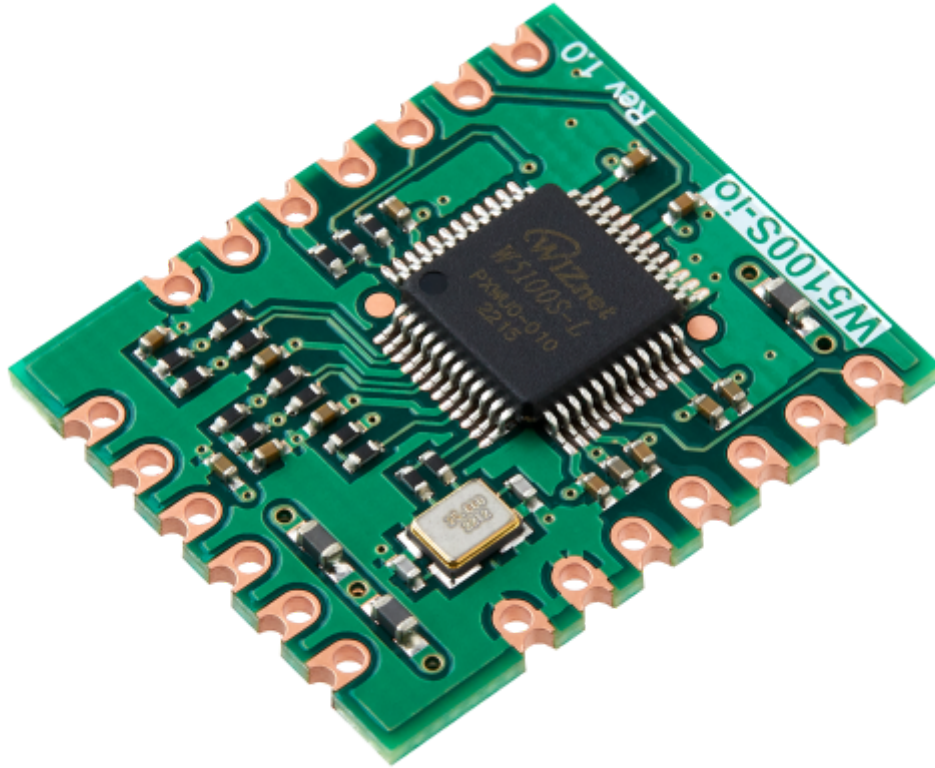

# Hardware Specification

## W5100S-io

- Plugin Network Module.
- Hardware compatible with W5500-io, W6100-io.

- Usable without H/W design for W5100S.
- Fast evaluation for W5100S & MCU in the target board.
- Support high speed SPI interface.
- Support power down mode and Wake-on-LAN function
- Very small form factor : 20mm x 24mm x 2.6mm

## Pin Out

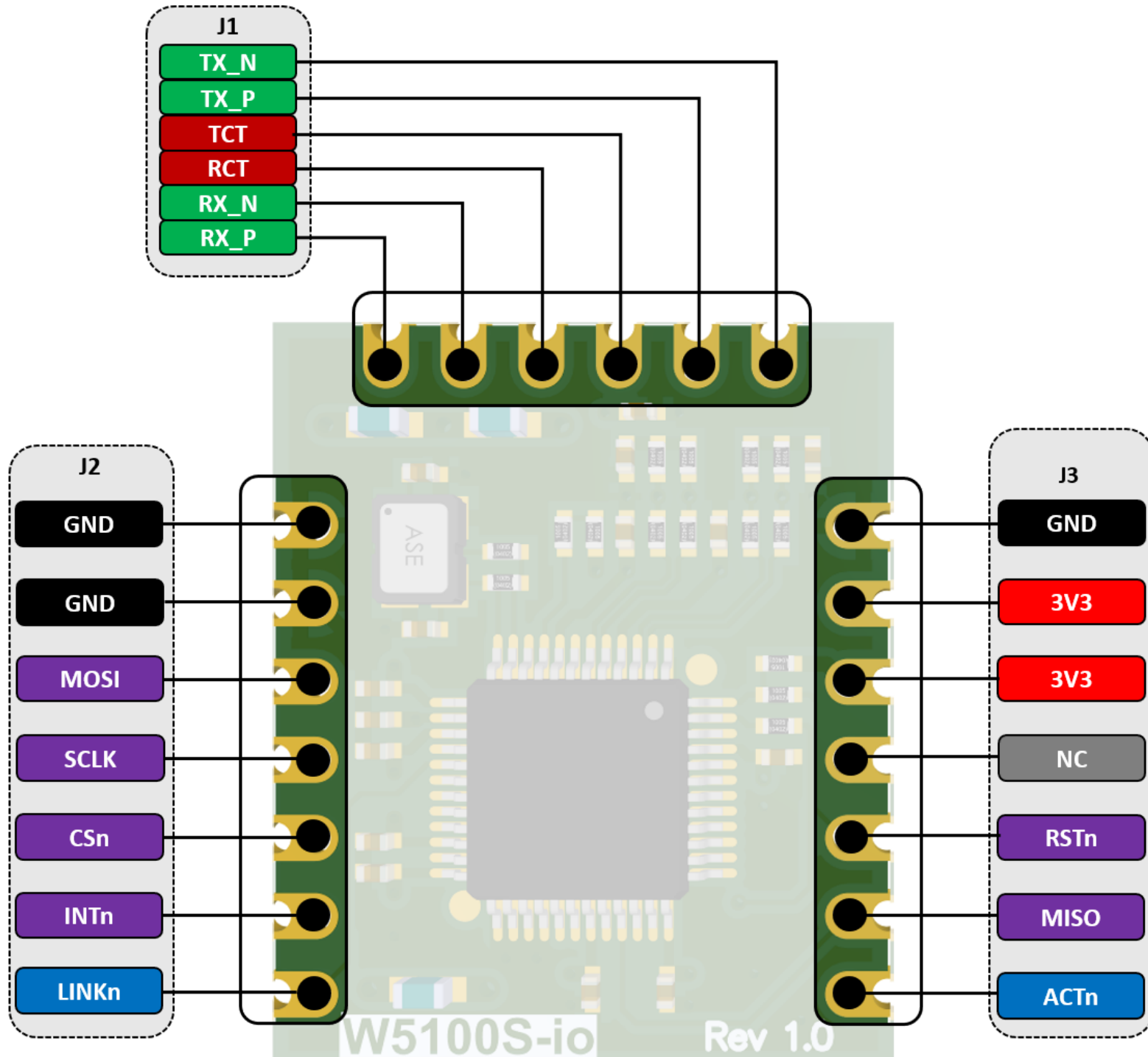

## Pin Description

Pin No.		Pin Type	Pin Name	Description
J1	1	I	RX_P	RX_P
⋮	2	I	RX_N	RX_N
⋮	3	P	RCT	<b>RX Center Tap</b> This pin should be connect with external pulse transformer's RCT pin
⋮	4	P	TCT	<b>TX Center Tap</b> This pin should be connect with external pulse transformer's TCT pin
⋮	5	O	TX_P	TX_P
⋮	6	O	TX_N	TX_N

Pin No.		Pin Type	Pin Name	Description
J2	1	P	GND	Ground
⋮	2	P	GND	Ground

Pin No.		Pin Type	Pin Name	Description
⋮	3	I	MOSI	<b>Master Out Slave In</b> This pin is used for SPI MOSI signal pin
⋮	4	I	SCLK	<b>SPI clock input</b>
⋮	5	I	CSn	<b>Chip select input</b>
⋮	6	O	INTn	<b>Interrupt output</b> Low: Interrupt asserted from W5100S High: No interrupt
⋮	7	O	LINK	<b>LINK status output</b> Low : Link High : Un Link

Pin No.		Pin Type	Pin Name	Description
J3	1	P	GND	<b>Ground</b>
⋮	2	P	3.3V	<b>Power</b> : 3.3V power supply
⋮	3	P	3.3V	<b>Power</b> : 3.3V power supply

Pin No.		Pin Type	Pin Name	Description
⋮	4	-	NC	<b>Not Connect</b>
⋮	5	I	RSTn	<b>Reset</b> : Low activity Hold at least 500us after asserted to LOW and keep HIGH until next Reset needed.
⋮	6	O	MISO	<b>SPI Master In Slave Out</b> This pin is used for SPI MISO signal pin
⋮	7	O	ACTn	<b>Active LED</b> Low: Carrier sense from the active PMD High: No carrier sense

-----

## Characteristic

### DC Characteristic

Symbol	Parameter	Pins	Min	Typ	Max	Unit
VDD	<b>Supply voltage</b>	3.3V	2.97	3.3	3.63	V
VIL	<b>High level input voltage</b>	ALL	2.0		5.5	V

<b>Symbol</b>	<b>Parameter</b>	<b>Pins</b>	<b>Min</b>	<b>Typ</b>	<b>Max</b>	<b>Unit</b>
<i>VIH</i>	<b>Low level input voltage</b>	ALL	-0.3		0.8	V
<i>VOL</i>	<b>Low level output voltage</b>	ALL			0.4	V
<i>VOH</i>	<b>High level output voltage</b>	ALL	2.4			V
<i>LOL</i>	<b>Low level output Current</b>	ALL	8.6	13.9	18.9	mA
<i>LOH</i>	<b>High level output Current</b>	ALL	12.5	26.9	47.1	mA
<i>IDD</i>	<b>Supply Current (Normal operation mode)</b>	3.3V		132		mA
<i>LOH</i>	<b>Supply Current (Power Down mode)</b>	3.3V		13		mA

## Power Dissipation

<b>Condition</b>	<b>Min</b>	<b>Typ</b>	<b>Max</b>	<b>Unit</b>
100M Link	-	93	110	mA
10M Link	-	93	210	mA



Condition	Min	Typ	Max	Unit
Un-Link (Auto-negotiation mode)	-	43	170	mA
Power Down mode	-	10	20	mA

## SPI Operations

As W5100S-io consists of W5100S and others, SPI operation of W5100S-io follows one of W5100S. For more information about SPI operation of W5100S-io, please refer to [W5100S Datasheet](#).

## Schematic & Artwork

### Module

- Revision 1.0 [W5100S-io V100 Schematic\(PDF\)](#)
- Revision 1.0 [W5100S-io V100 Schematic\(Altium\)](#)

### Reference Schematic

- Revision 1.0 [W5100s-io V100 Reference Schematic\(PDF\)](#)

# Part list

- Revision 1.0 [W5100S-io V100 Part list\(PDF\)](#)
- Revision 1.0 [W5100S-io V100 Part list\(Excel\)](#)

# Dimension

- W5100S-io V100 Dimension
  - 24mm x 20mm x 1.0mm ( PCB board size )
  - 24mm x 20mm x 2.6mm ( Included part size )

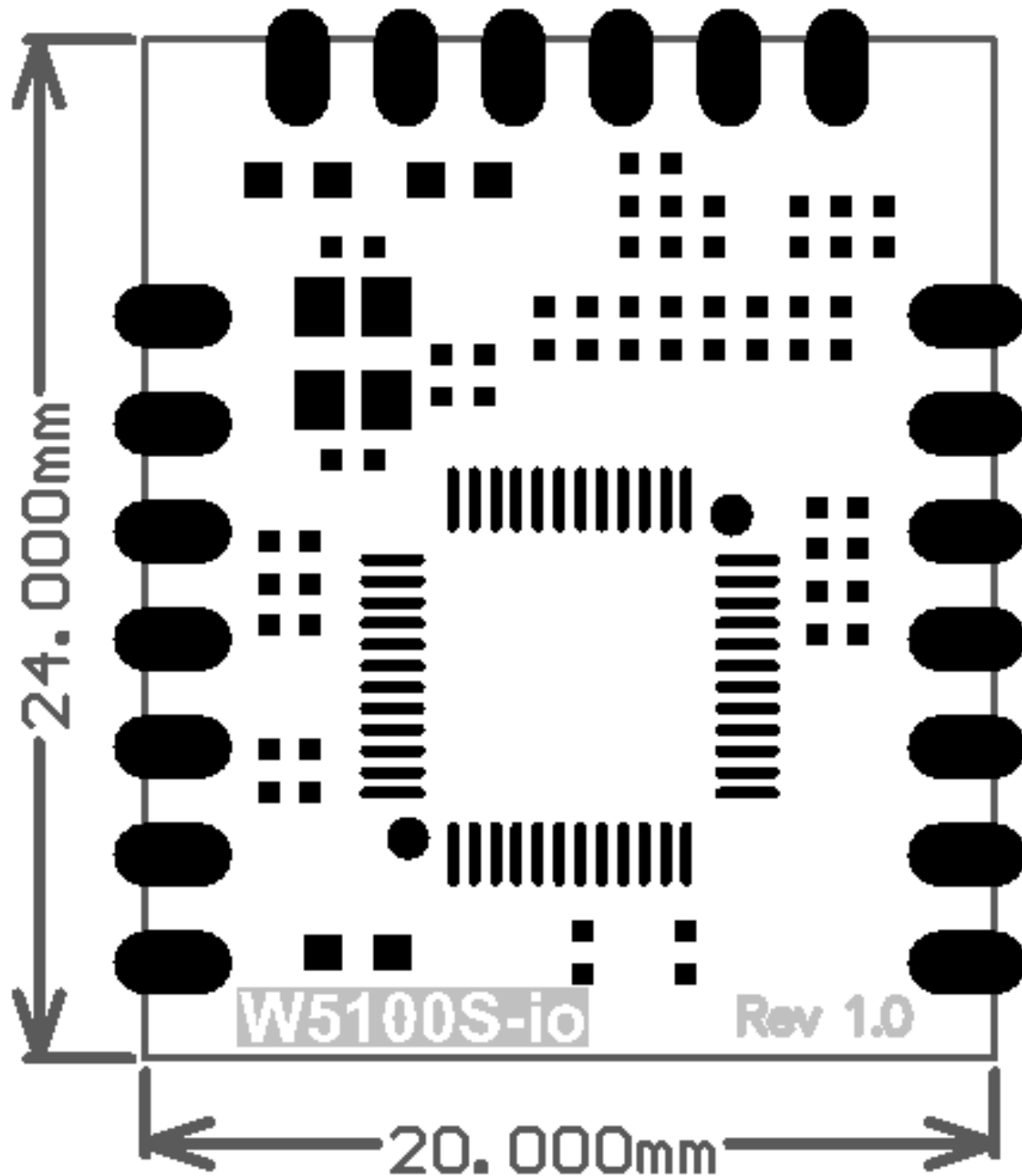

 [Edit this page](#)