



DATASHEET

Type	Whip Antenna
Frequencies	AMPS (824-894 MHz) ISM (868 MHz) GSM (900 MHz) DCS (1800 MHz) PCS (1900 MHz) 3G (UMTS 2.1 GHz) WIFI / BLUETOOTH (2.4 GHz)
Mounting	Body Mount
Part No.	2J121B
Revision	00



D. Noble

1. SPECIFICATION

1.1. Electrical Specifications

Frequencies	AMPS (824-894 MHz) ISM (868 MHz) GSM (900 MHz) DCS (1800 MHz) PCS (1900 MHz) 3G (UMTS 2.1 GHz) WIFI / BLUETOOTH (2.4 GHz)
Impedance	50 Ohms
Polarization	VERTICAL
Gain	3 - 4dBi
VSWR	<3:1
Power handling	100W
Operating temperature	-40°C to +85°C

1.2. Connection Specifications

Cable type: RG58
 Connector: Upon request
 Cable length: Upon request

1.3. Mechanical Specifications and Dimensions

1.3.1. Mounting Type

- Body Mount

1.3.2. Body mount

Max. dimensions: 29mm x 231mm (D x H)
 Weight: 115 g 'weight with 2m cable'
 Colour: Black (for different colours please ask our sales team)

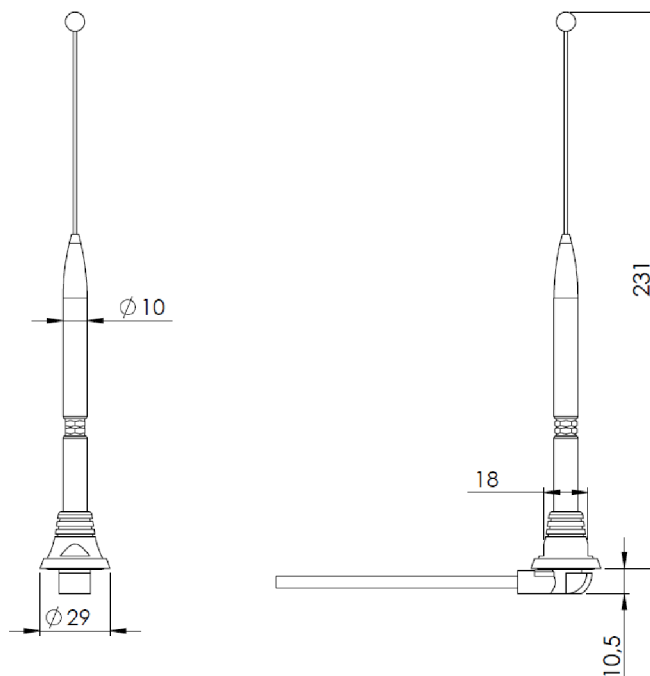

2. MEASUREMENT

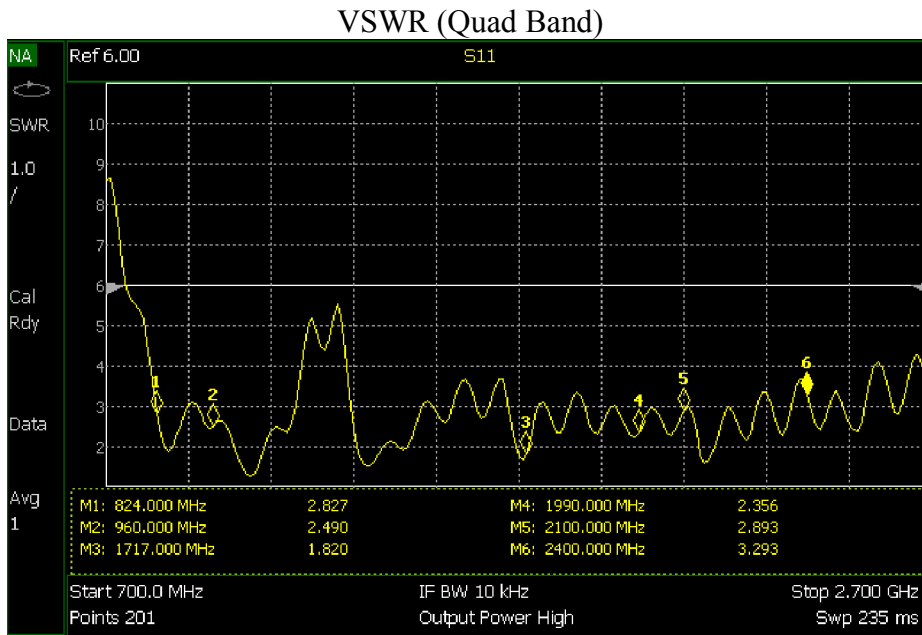

Tested with 1m cable length

3. PICTURES

