

ASSEMBLY - TOP

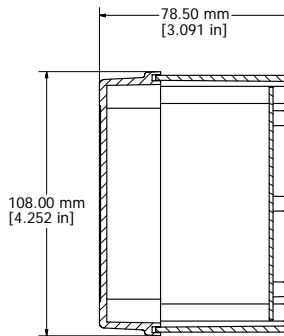

SECTION A-A

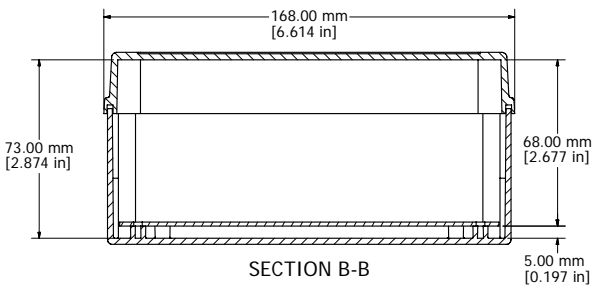

SECTION B-B

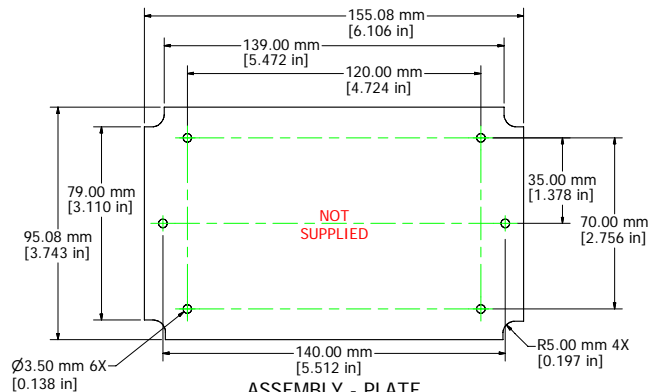

ASSEMBLY - PLATE

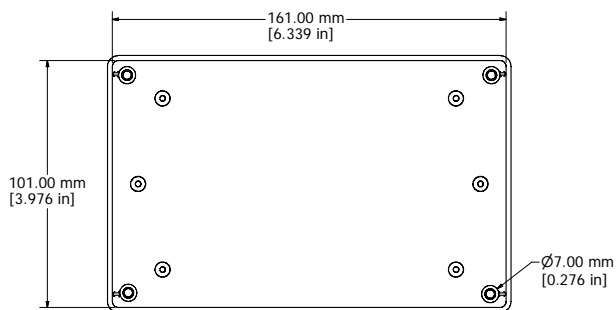

ASSEMBLY - INSIDE (BOX)

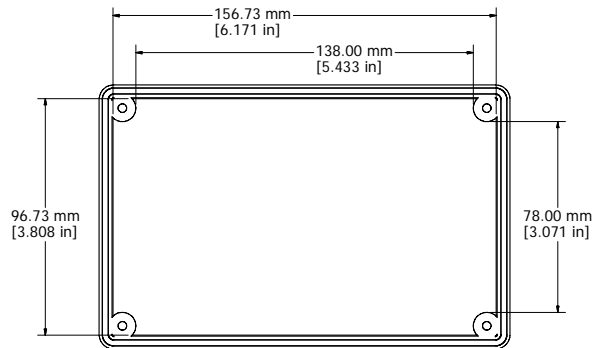

ASSEMBLY - INSIDE (LID)

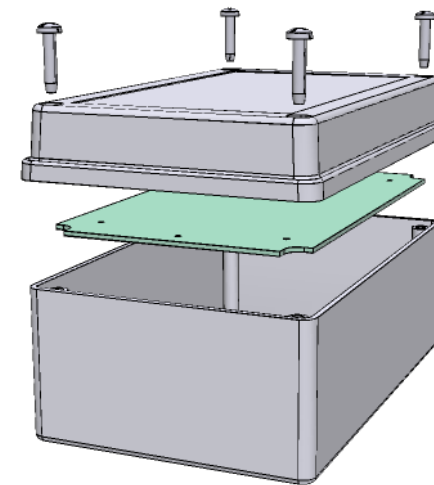

Note:

Enclosures can be Factory Modified (Milling, Drilling, Printing etc.)
 Contact Factory mjm@hammondmfg.com for quotes
 Solid models of this enclosure available in STEP or IGES Format.

RS5105S

Box Material: ABS (UL94-HB), Light Gray Color
 Lid Screws: M4 x 22 self tap, 304 Stainless
 Gasket: EDPM Cord.
 Circuit Board Screws, 4 Supplied (M3 self tap)
 Suggested Lid Screw Torque: 30 ozf-in (21 cN-m)



HAMMOND
 MANUFACTURING™

RS5305S

www.hammondmfg.com