

SEN6x – Datasheet

3rd Generation Environmental Sensor Node for Air Quality Applications



Highlights

- PM, RH&T, VOC, NO_x, CO₂/HCHO sensing platform
- Fast & easy integration
- 10 years dust-free – Patented Sheath Flow technology
- Fully calibrated digital output
- One driver for up to 9 data signals
- Integrated compensation algorithms
- Ready for California Title 24¹, RESET^{®2} and WELL Building Standard^{™3}

The SEN6x sensor module family is an air quality platform that combines critical parameters such as particulate matter, relative humidity, temperature, VOC, NO_x and either CO₂ or formaldehyde, all in one compact package. The modules are a result of Sensirion’s extensive experience in environmental sensing and offer the best possible performance for each parameter, a superior lifetime and an unrivaled form factor. The combination of all measurement parameters, together with all relevant algorithms in one device simplifies the integration, streamlines the supply chain, and allows for a fast time to market with the best performance.

Product Overview

Product Variant	Sensor Signals
SEN60	PM
SEN63C	PM, RH & T, CO ₂
SEN65	PM, RH & T, VOC, NO _x
SEN66	PM, RH & T, VOC, NO _x , CO ₂
SEN68	PM, RH & T, VOC, NO _x , HCHO

See full product list on page 42



Scan me to provide feedback

Functional Block Diagram

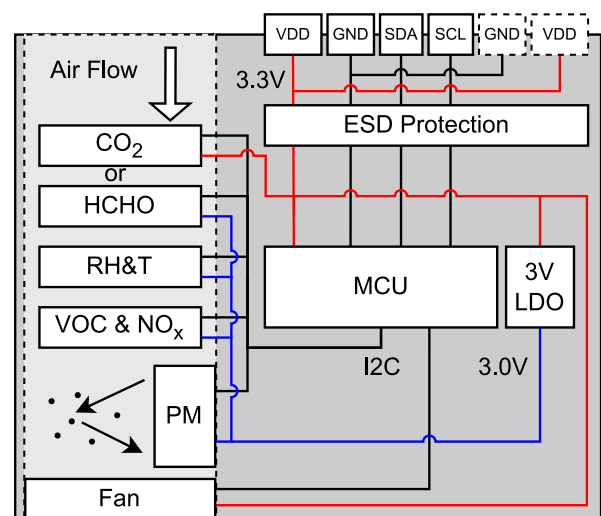

¹ 2022 California Building Energy Efficiency Standards for Residential and Nonresidential Buildings

² RESET Air Standard v2.0

³ WELL v2 pilot, Q4 2022

Contents

1	Disclaimer	4
2	Environmental Sensor Node Specifications	4
2.1	Sensor Module Specifications	4
2.2	Particulate Matter Specifications	5
2.2.1	Laser Safety	5
2.3	Temperature and Humidity Specifications	6
2.4	VOC and NO _x Specifications	7
2.5	CO ₂ Specifications	8
2.5.1	CO ₂ Specifications – SEN66	8
2.5.2	CO ₂ Specifications – SEN63C	8
2.6	Formaldehyde Specifications	9
2.7	Recommended and Absolute Maximum and Minimum Operating and Storage Conditions	10
2.7.1	SEN60	10
2.7.2	SEN63C, SEN65 and SEN66	11
2.7.3	SEN68	12
3	Electrical Specifications	13
3.1	Electrical Characteristics	13
3.2	Absolute Maximum Ratings	14
3.3	ESD / EMC Ratings	14
3.3.1	Immunity	14
3.3.2	Emission	14
4	Hardware Interface Description	15
4.1	I ² C Interface Circuit	15
5	Digital Interface Description	16
5.1	Operation Modes	16
5.2	Temperature Compensation with STAR Engine	16
5.3	I ² C Interface Settings	16
5.4	Power-Up and Communication Start	17
5.5	Data Type & Length	17
5.6	Command Sequence Types	18
5.7	I ² C Commands	19
5.7.1	Start Continuous Measurement	20
5.7.2	Stop Measurement	20
5.7.3	Get Data Ready	21
5.7.4	Read Measured Values SEN66	22
5.7.5	Read Number Concentration Values	23
5.7.6	Read Measured Raw Values SEN66	24
5.7.7	Start Fan Cleaning	24
5.7.8	Set Temperature Offset Parameters	25
5.7.9	Get VOC Algorithm Tuning Parameters	26

5.7.10 Set VOC Algorithm Tuning Parameters27

5.7.11 Get NO_x Algorithm Tuning Parameters28

5.7.12 Set NO_x Algorithm Tuning Parameters29

5.7.13 Set Temperature Acceleration Parameters30

5.7.14 Get VOC Algorithm State31

5.7.15 Set VOC Algorithm State32

5.7.16 Perform Forced CO₂ Recalibration.....32

5.7.17 Get CO₂ Sensor Automatic Self Calibration.....33

5.7.18 Set CO₂ Sensor Automatic Self Calibration33

5.7.19 Get Ambient Pressure34

5.7.20 Sets Ambient Pressure.....34

5.7.21 Get Sensor Altitude.....35

5.7.22 Set Sensor Altitude.....35

5.7.23 Activate SHT Heater.....36

5.7.24 Get Product Name.....36

5.7.25 Get Serial Number37

5.7.26 Get Version.....38

5.7.27 Read Device Status.....39

5.7.28 Read And Clear Device Status39

5.7.29 Device Reset40

5.8 Checksum Calculation (CRC).....40

6 Technical Drawing41

6.1 Package Outline.....41

6.2 Product Label.....42

7 Ordering Information.....43

8 Bibliography.....44

9 Revision History.....44

1 Disclaimer

This is a preliminary datasheet; all specifications are to be understood as target specifications and can change without notice.

2 Environmental Sensor Node Specifications

For section 2.1 to 2.6, default conditions of continuous measurement-mode, 25 °C, 50 %RH (relative humidity), 1013 mbar, and 3.3 V supply voltage apply, unless stated otherwise.

Different products within the SEN6x family offer different sensing capabilities. Specifications in the following only apply if the parameter is present in the selected product.

2.1 Sensor Module Specifications

Applies to: SEN60, SEN63C, SEN65, SEN66, SEN68

Parameter	Conditions	Value	Units
Sampling interval	-	1 ± 0.03	s
Sensor startup time (Time after power-on until I2C communication can be started)	-	100	ms
Lifetime ⁴	24 h/day operation ⁵	> 10 ⁶	years
Acoustic emission level	0.2 m	< 24	dB(A)
Long term acoustic emission level drift	0.2 m	+0.5	dB(A) / year
Weight	-	20 ± 10 %	g

Table 1. Sensor Module Specifications

⁴ Lifetime is based on mean-time-to-failure (MTTF) calculation. Lifetime might vary depending on different operating conditions. For more details refer to "Sensor Specification Statement – Rev.2" [4]

⁵ For an indoor air quality mission profile

⁶ Excluding formaldehyde specifications, formaldehyde lifetime limited to > 6 years

2.2 Particulate Matter Specifications

Applies to: SEN60, SEN63C, SEN65, SEN66, SEN68

Parameter	Conditions		Value	Units
Mass concentration specified range	-		0 to 1'000	µg/m ³
Mass concentration size range	PM1.0		0.3 to 1.0	µm
	PM2.5		0.3 to 2.5	µm
	PM4		0.3 to 4.0	µm
	PM10		0.3 to 10.0	µm
Mass concentration precision ^{7,10} for PM1 and PM2.5 ⁸	0 to 100 µg/m ³		±5 µg/m ³ AND 5 % m.v.	
	100 to 1000 µg/m ³		±10	% m.v.
Mass concentration precision ^{7,10} for PM4, PM10 ⁹	0 to 100 µg/m ³		±25	µg/m ³
	100 to 1000 µg/m ³		±25	% m.v.
Maximum long-term mass concentration precision limit drift ¹⁰	0 to 100 µg/m ³		±1.25	µg/m ³ / year
	100 to 1000 µg/m ³		±1.25	% m.v. / year
Typical start-up time ¹¹	-		30	s
Sensor output characteristics	PM2.5 mass concentration		Calibrated to TSI DustTrak™ DRX 8533 Ambient Mode	
Additional T-dependent mass precision limit drift ¹⁰	temperature difference to 25°C	typ.	±0.5	% m.v. / °C
Laser wavelength (IEC 60825-1:2014 and DIN EN 60825-1:2022 Class 1)		typ.	850	nm

Table 2. Particulate matter sensor specifications. ‘% m.v.’ means ‘% of measured value’.

2.2.1 Laser Safety

This product contains a Class 3R laser source. With its housing, it is a laser class 1 product according to IEC 60825-1:2014 and DIN EN 60825-1:2022. Do not open for servicing.

⁷ Also referred to as “between-parts variation” or “device-to-device variation”.

⁸ Verification Aerosol for PM2.5 is a 3% atomized KCl solution. Deviation to reference instrument is verified in end-tests for every sensor after calibration.

⁹ PM4 and PM10 output values are calculated based on distribution profile of all measured particles.

¹⁰ For more details refer to “Sensirion Environmental Node Sensor Specification Statement – Rev.2” [4]

¹¹ Time after starting continuous measurement-mode, until a stable measurement is obtained.

2.3 Temperature and Humidity Specifications

Applies to: SEN63C, SEN65, SEN66, SEN68

Parameter	Conditions	Value ¹²			Units
		Min	Typ.	Max	
Compensated outputs ¹³	-	Temperature			°C
		Relative Humidity			%RH
Accuracy temperature	@ 15-30 °C, 50 %RH		±0.45	±0.7	°C
Repeatability temperature	@ 25 °C, 50 %RH		0.1		°C
Response time temperature ¹⁴	@ 25 °C, 50 %RH, $\tau_{63\%}$		<60		s
Accuracy relative humidity	@ 25 °C, 30-70 %RH		±4.5	±6	%RH
Repeatability relative humidity	@ 25 °C, 50 %RH		±1		%RH
Response time relative humidity ¹⁵	@ 25 °C, 50 %RH, $\tau_{63\%}$		<20		s

Table 3. Temperature and humidity specifications

¹² For the definition of the typical and max. accuracy tolerance, please refer to the document “Sensirion Humidity Sensor Specification Statement” [5].

¹³ Self-heating of the module is compensated according to the application note “Temperature Acceleration and Compensation Instructions for SEN6x” [2].

¹⁴ For a step from 15°C to 25°C, for a bare module with default acceleration and offset parameters

¹⁵ For a step from 75%RH to 25%RH, for a bare module with default acceleration and offset parameters.

2.4 VOC and NO_x Specifications

Applies to: SEN65, SEN66, SEN68

Parameter	Comments	Values			Units	
		Min.	Typ. ¹⁶	Max.		
Output signals	VOC Index	1	–	500	VOC Index points	
	NO _x Index	1	–	500	NO _x Index points	
Device-to-device variation	VOC Index ¹⁷	–	<±15 <±15	–	VOC Index points or % VOC Index m.v. (the larger)	
	NO _x Index ¹⁷	–	<±50 <±50	–	NO _x Index points or % NO _x Index m.v. (the larger)	
Repeatability	VOC Index ¹⁷	–	<±5 <±5	–	VOC Index points or % VOC Index m.v. (the larger)	
	NO _x Index ¹⁷	–	<±10 <±10	–	NO _x Index points or % NO _x Index m.v. (the larger)	
Response time	Changing concentration from 5 to 10 ppm of ethanol, at sampling interval of 1 s	τ ₆₃	–	<10	–	s
		τ ₉₀	–	<30	–	s
Switch-on behavior	Time until reliably detecting events ¹⁸	–	<60	–	s	
	Time until specifications in this table are met	VOC Index	<1	–	h	
		NO _x Index	<6	–	h	

Table 4. VOC and NO_x sensing specifications in zero air (considered as clean air for indoor air quality applications). All concentrations refer to ethanol as test gas.

¹⁶ 95% of the sensors will be within the typical tolerance corresponding to 2σ assuming a normal distribution for ≥100 sensors.

¹⁷ Evaluated using the calibration and test sequence according to the application note “SGP40 – Quick Testing Guide” [6].

¹⁸ Signal change during 60s event of 5'000 to 10'000 ppb of ethanol or of 100 to 300 ppb of NO₂ is three times larger than raw signals drift, without this event during the same duration.

2.5 CO₂ Specifications

2.5.1 CO₂ Specifications – SEN66

Applies to: SEN66 only

Parameter	Conditions	Value	Units
CO ₂ output range ¹⁹	-	0 to 40'000	ppm
CO ₂ measurement accuracy ²⁰	400 ppm to 1'000 ppm	±(50 + 2.5 % of reading)	ppm
	1'001 ppm to 2'000 ppm	±(50 + 3 % of reading)	ppm
	2'001 ppm to 5'000 ppm	±(40 + 5 % of reading)	ppm
Repeatability	typ.	±10	ppm
Response time ²¹	$\tau_{63\%}$, typical, step change 400 – 2'000 ppm	60	s
Additional accuracy drift per year, starting after five years ²²	400 to 5000 ppm, typ.	±(5 + 0.5 % of reading)	ppm

Table 5. CO₂ specifications

2.5.2 CO₂ Specifications – SEN63C

Applies to: SEN63C only

Parameter	Conditions	Value	Units
CO ₂ output range	-	0 to 32'000	ppm
CO ₂ measurement accuracy ²³	400 ppm to 5'000 ppm	±(100 + 10 % of reading)	ppm
Response time ²⁴	$\tau_{63\%}$, typ.	20	s

Table 6. CO₂ specifications

¹⁹ Exposure to CO₂ concentrations smaller than 400 ppm can affect the accuracy of the sensor with ASC enabled.

²⁰ Deviation from a high-precision reference with gas mixtures having a ±2% tolerance. Rough handling, shipping and long-term drift can impact sensor accuracy. Accuracy can be restored by performing forced recalibration (FRC) or maintained by sensor operation with automatic self-calibration (ASC) enabled using default parameters and weekly exposure to air with CO₂ concentrations at 400 ppm.

²¹ Response time depends on design-in and environment of the sensor in the final application.

²² Deviation is additional to standard accuracy specifications and obtained either after performing FRC or in continuous sensor operation with ASC enabled using default parameters and weekly exposure to air with CO₂ concentrations at 400 ppm. Maximum additional accuracy drift per year starting after five years estimated from stress tests is ± (5 ppm + 2% of reading). Stronger drift may occur if the sensor is not handled according to its handling instructions.

²³ Accuracy is achieved after initial operation for 12h, followed by exposure to fresh air.

²⁴ Time for achieving 63% of a step change from 2000-400 ppm when operating the SEN63C in measurement mode. Response time depends on design-in and environment of the sensor in the final application.

2.6 Formaldehyde Specifications

Applies to: SEN68

Parameter	Conditions	Value	Units
Formaldehyde concentration measurement range	-	0 to 1000	ppb
Typical Accuracy	0 to 200 ppb HCHO in clean air	± 20 ppb or $\pm 20\%$ of measured value, whichever is larger	-
Accuracy in VOC background	100 ppb HCHO in background of 5 ppm of ethanol	+35 to -20	ppb
Cross-sensitivity to ethanol	Tested in 5 ppm ethanol	≤ 0.3	%
Resolution	-	0.1	ppb
Start-up time	Time until sensor output is within specifications	≤ 5	min
Lifetime	Standard conditions as defined in section 2	≥ 6	years

Table 7. Formaldehyde specifications

2.7 Recommended and Absolute Maximum and Minimum Operating and Storage Conditions

The SEN6x family contains different sensing components with different operating and storage ranges. Make sure to select the appropriate table for the selected product.

2.7.1 SEN60

Table 8 and Figure 1 show the recommended operating and storage conditions in which all the sensing components of the SEN60 show the best performance, as well as absolute maximum/minimum conditions which must not be exceeded.

Exposure to conditions outside the recommended range may temporarily reduce sensor performance (PM precision). Exposure to conditions outside the absolute maximum/minimum range may lead to permanent damage to the device.

The sensor must not be exposed towards condensing conditions at any time.

Condition	Parameter	Recommended		Short-Term Maximum/Minimum ²⁵		Unit
		Min.	Max.	Min.	Max.	
Operating conditions	Temperature	10	40	-10	60	°C
	Relative humidity	20	80	0	95 (non-condensing)	% RH
Storage conditions	Temperature	10	30	-40	70	°C
	Relative Humidity	20	60	0	95 (non-condensing)	% RH

Table 8. Recommended and absolute maximum/minimum operating and storage conditions for the SEN60

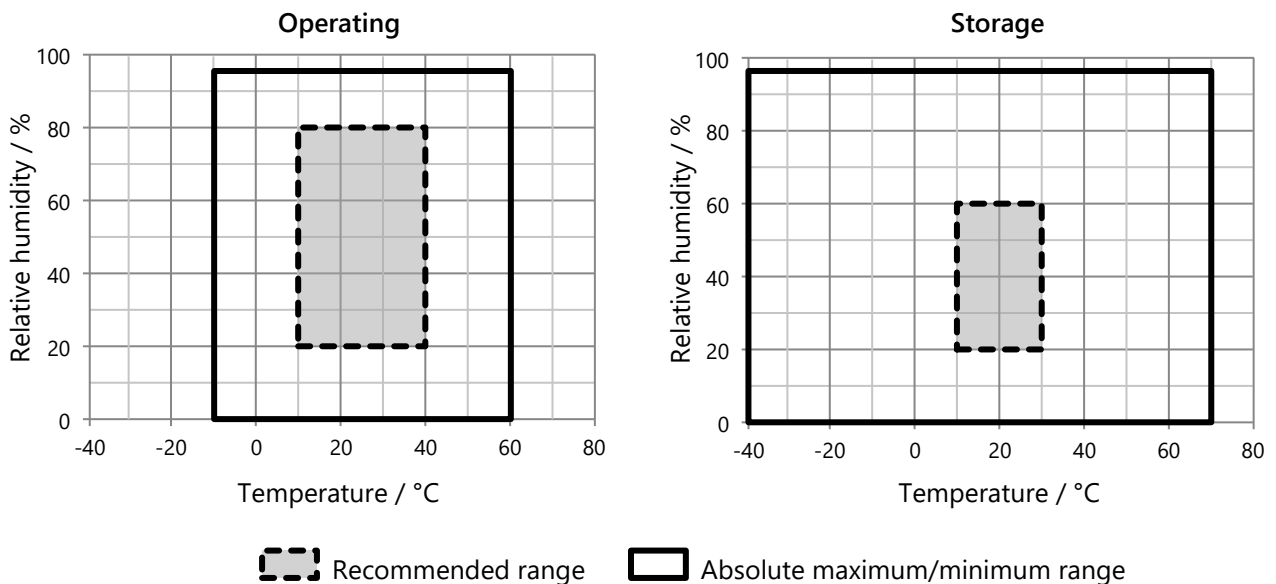

Figure 1. Recommended and absolute maximum/minimum operating and storage conditions for the SEN60

²⁵ Short-term storage refers to temporary conditions, e.g., transport.

2.7.2 SEN63C, SEN65 and SEN66

Table 9 and **Figure 2** show the recommended operating and storage conditions in which all the sensing components of the SEN63C, SEN65 and SEN66 show the best performance, as well as absolute maximum/minimum conditions which must not be exceeded. Gas sensing specifications are guaranteed only when the SEN63C, SEN65 and SEN66 are operated and stored under the recommended conditions given in **Table 9** and **Figure 2**.

Exposure to conditions outside the recommended range may temporarily reduce sensor performance (reversible RH drift, reduced RH, T, VOC, NO_x, CO₂, PM precision). Exposure to conditions outside the absolute maximum/minimum range may lead to permanently reduced sensor performance (VOC and NO_x sensitivity drift) or cause permanent damage to the device.

The sensor must not be exposed towards condensing conditions at any time.

Condition	Parameter	Recommended		Short Term- Maximum/Minimum ²⁶		Unit
		Min.	Max.	Min.	Max.	
Operating conditions	Temperature	10	40	-10	50	°C
	Relative humidity	20	80	0	90 (non-condensing)	% RH
Storage conditions	Temperature	10	30	-40	70	°C
	Relative Humidity	20	60	0	80 (non-condensing)	% RH

Table 9. Recommended and absolute maximum/minimum operating and storage conditions for the SEN63C, SEN65 and SEN66

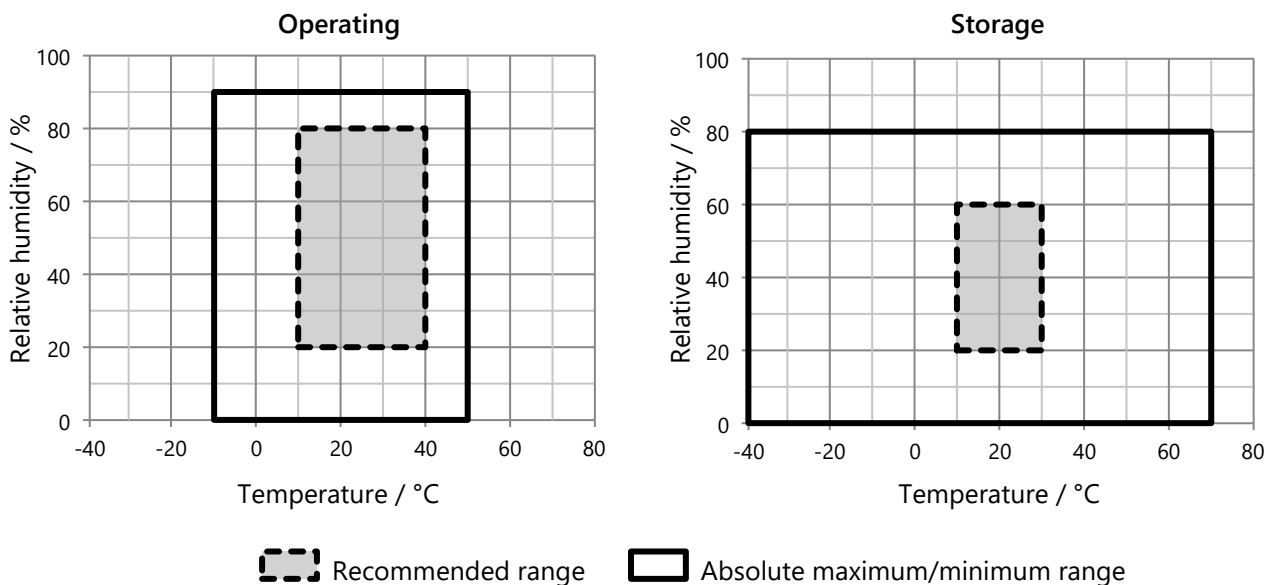

Figure 2. Recommended and absolute maximum/minimum operating and storage conditions for the SEN63, SEN65 and SEN66

²⁶ Short-term storage refers to temporary conditions, e.g., transport.

2.7.3 SEN68

Table 10 and Figure 3 show the recommended operating and storage conditions in which all the sensing components of the SEN68 show the best performance, as well as absolute maximum/minimum conditions which must not be exceeded. Gas sensing specifications are guaranteed only when the SEN68 is operated and stored under the recommended conditions given in Table 10 and Figure 3.

Exposure to conditions outside the recommended range may temporarily reduce sensor performance (reversible RH drift, reduced RH, T, VOC, NO_x, HCHO, PM precision). Exposure to conditions outside the absolute maximum/minimum range may lead to permanently reduced sensor performance (VOC, NO_x and HCHO sensitivity drift) or cause permanent damage to the device.

The sensor must not be exposed towards condensing conditions at any time.

Condition	Parameter	Recommended		Short-Term Maximum/Minimum ²⁷		Unit
		Min.	Max.	Min.	Max.	
Operating conditions	Temperature	10	40	0	50	°C
	Relative humidity	20	80	15	90 (non-condensing)	% RH
Storage conditions	Temperature	10	30	-20	70	°C
	Relative Humidity	30	60	10	80 (non-condensing)	% RH

Table 10. Recommended and absolute maximum/minimum operating and storage conditions for the SEN68

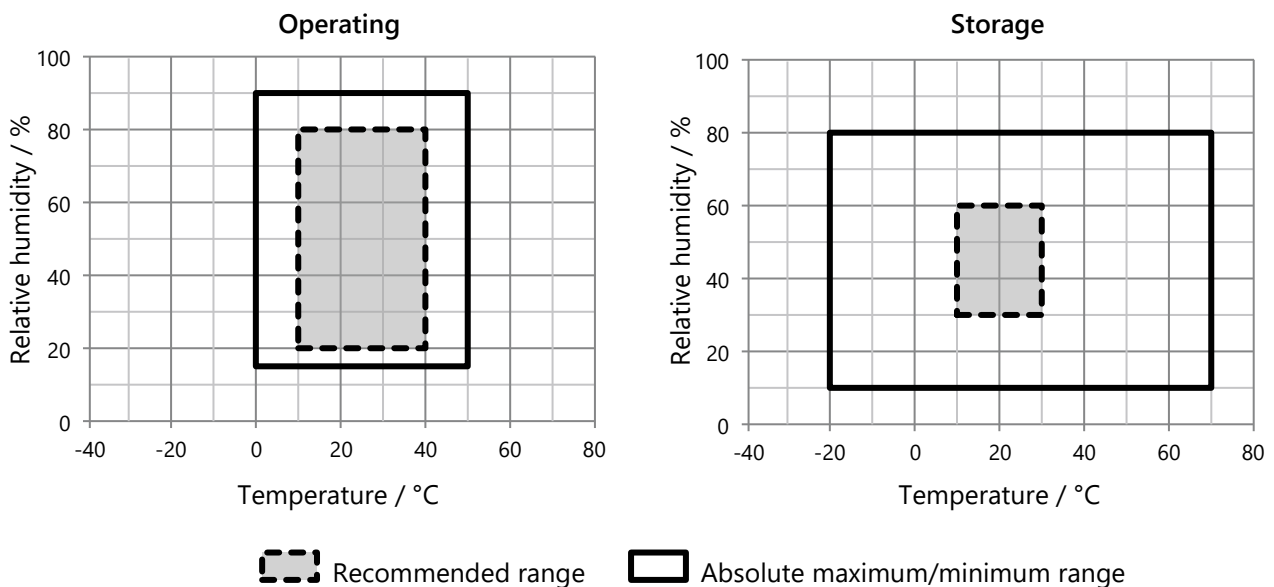

Figure 3. Recommended and absolute maximum/minimum operating and storage conditions for the SEN68

²⁷ Short-term storage refers to temporary conditions, e.g., transport.

3 Electrical Specifications

3.1 Electrical Characteristics

Applies to: SEN60, SEN63C, SEN65, SEN66, SEN68

Parameter	Conditions		Min	Typ.	Max	Unit
Supply voltage (V_{DD})	-		3.15 ²⁸	3.3	3.45	V
Supply voltage peak to peak ripple ($V_{DD,pp}$)	≥ 100 Hz	SEN6x	-	-	100	mV
	< 100 Hz	SEN66	-	-	30	
		SEN6x	-	-	100	
Average supply current ²⁹	Idle Mode (first 10 seconds)	SEN60		3.3		mA
		SEN63C		3.3		
		SEN65		4.6		
		SEN66		4.6		
		SEN68		4.6		
	Idle Mode (after first 10 seconds)	SEN60	-	3.3	-	
		SEN63C	-	3.3	-	
		SEN65	-	3.3	-	
		SEN66	-	3.3	-	
		SEN68	-	3.3	-	
	Measurement-Mode (after first 60 seconds)	SEN60	-	75	90	
		SEN63C	-	80	100	
		SEN65	-	80	100	
		SEN66	-	90	110	
		SEN68	-	75	100	
Peak supply current	Measurement mode (pulse width of 2 ms)	SEN60	-	130	190	
		SEN63C	-	140	200	
		SEN65	-	140	200	
		SEN66	-	300	350	
		SEN68	-	140	200	
SDA/SCL pin input high voltage (V_{IH})	-		$0.7 \cdot V_{DD}$	-	-	V
SDA/SCL pin input low voltage (V_{IL})	-		-	-	$0.3 \cdot V_{DD}$	
SDA pin output low voltage (V_{OH})	-		-	-	0.45	

Table 11. Electrical Specifications at 25°C

²⁸ Minimum voltage including ripples.

²⁹ Averaged over 5 seconds

3.2 Absolute Maximum Ratings

Applies to: SEN60, SEN63C, SEN65, SEN66, SEN68

Stress levels beyond those listed in **Table 12** may cause permanent damage to the device. These are stress ratings only and functional operation of the device at these conditions cannot be guaranteed. Exposure to the absolute maximum rating conditions for extended periods may affect the reliability of the device.

Parameter	Min	Max	Unit
Supply voltage VDD	0	3.6	V
I/O pins (SDA, SCL)	-0.3	5.5	
Max. current on any I/O pin	-20	20	mA

Table 12. Absolute minimum and maximum ratings

3.3 ESD / EMC Ratings

3.3.1 Immunity

Applies to: SEN60, SEN63C, SEN65, SEN66, SEN68

Description	Standard	Rating
Electrostatic Discharge	IEC 61000-4-2	±4 kV contact, ±4 kV air
Power-Frequency Magnetic Field	IEC 61000-4-8	30 A/m, 50 Hz and 60 Hz
Radio-Frequency EM-Field AM-modulated	IEC 61000-4-3	80 MHz – 1000 MHz, 3 V/m, 80% AM @1 kHz
Radio-Frequency EM-Field AM-modulated	IEC 61000-4-3	1.4 GHz – 6 GHz, 3 V/m, 80% AM @1 kHz

Table 13. ESD and EMC immunity

3.3.2 Emission

Applies to: SEN60, SEN63C, SEN65, SEN66, SEN68

Description	Standard	Rating
Emission in SAC for 30MHz to 230MHz	IEC/CISPR 16	40 dB(µV/m) QP @3m
Emission in SAC for 230MHz to 1000MHz	IEC/CISPR 16	47 dB(µV/m) QP @3m

Table 14. EMC emission

4 Hardware Interface Description

Applies to: SEN60, SEN63C, SEN65, SEN66, SEN68

The sensor is equipped with a serial communication interface. In Table 16, a description of the pin layout is given.

Part	Description
Connector sensor side	ACES 51451-0060N-001
Connector cable side	Compatible with ACES 51452-006H0H0-001 (e.g., JST GHR-06V-S)
Cable cross section area	≥AWG26 (≥0.128 mm ²)
Cable length	≤50 cm

Table 15. SEN6x physical interface

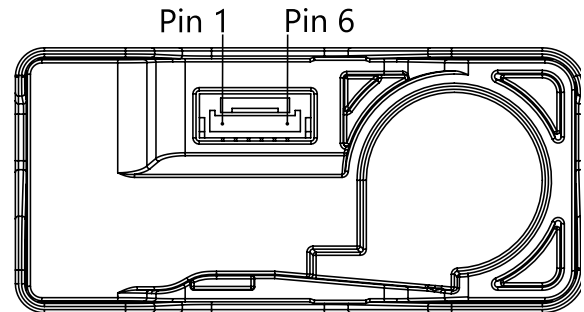

Figure 4. Pin layout. The communication interface connector (ACES 51451-0060N-001) is located at the side of the sensor adjacent to the air outlet.

Pin	Name	Description	Comments
1	VDD	Supply voltage	-
2	GND	Ground	-
3	SDA	Serial data input/output	TTL 5V compatible
4	SCL	Serial clock input	TTL 5V compatible
5	GND	Ground or NC	Pins 2 and 5 are connected internally
6	VDD	Supply voltage or NC	Pins 1 and 6 are connected internally

Table 16. SEN6x pin assignment

4.1 I²C Interface Circuit

Applies to: SEN60, SEN63C, SEN65, SEN66, SEN68

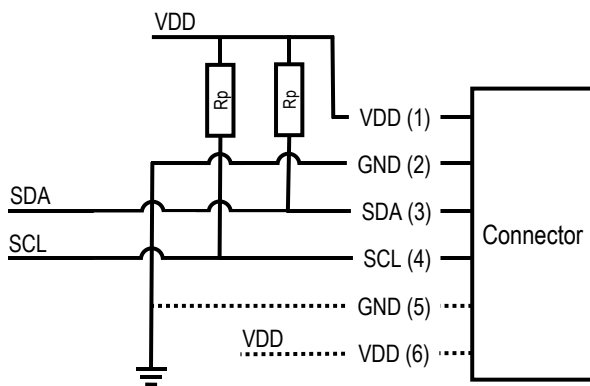

Figure 5. I²C application circuit

Both SCL and SDA lines are open drain I/Os. They must be connected to external pull-up resistors (e.g. $R_p = 10\text{ k}\Omega$).

Some considerations should be made about the use of the I²C interface. I²C was originally designed to connect two chips on a PCB. When the sensor is connected to the main PCB via a cable, particular attention must be paid to electromagnetic interference and crosstalk. Use as short as possible (< 10 cm) and/or well shielded connection cables.

For detailed information on the I²C protocol, refer to NXP I²C-bus specification [1].

5 Digital Interface Description

5.1 Operation Modes

Applies to: SEN60, SEN63C, SEN65, SEN66, SEN68

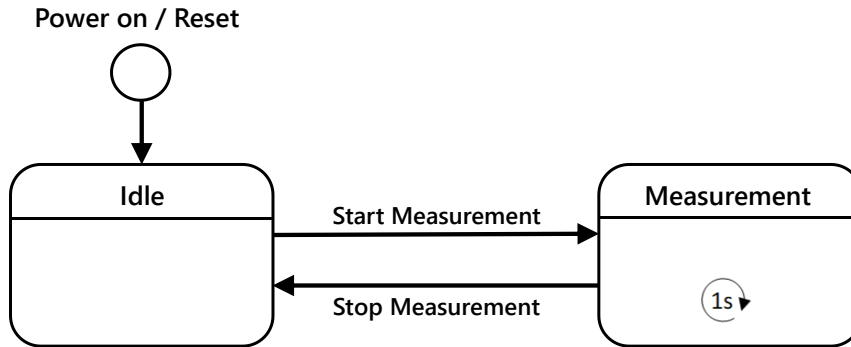

Figure 6. SEN6x operating modes

Idle:

- The module is in Idle Mode after power on or reset.
- Most of the internal electronics switched off /reduced power consumption.
- Fan and laser are switched off.
- The module is ready to receive and process any command.

Measurement:

- All electronics switched on / max. power consumption.
- The measurement is running, and the module is continuously processing measurement data.
- New readings are available every second.

5.2 Temperature Compensation with STAR Engine

Applies to: SEN63C, SEN65, SEN66, SEN68

By default, the temperature and humidity outputs from the sensor are compensated for the modules self-heating. If the module is designed into a device, the temperature compensation might need to be adapted to incorporate the change in thermal coupling and self-heating of other device components. A guide to achieve optimal performance, including references to mechanical design-in examples can be found in the app note "Temperature Acceleration and Compensation Instructions for SEN6x" [2].

5.3 I²C Interface Settings

Applies to: SEN60, SEN63C, SEN65, SEN66, SEN68

Property	SEN60	SEN6x
I ² C Address	0x6C (7-bit)	0x6B (7-bit)
Max. Speed	100kbit/s (standard mode)	
Clock stretching	Not used, the sensor NACKS's when busy with processing	

Table 17. I²C interface settings

5.4 Power-Up and Communication Start

Applies to: SEN60, SEN63C, SEN65, SEN66, SEN68

The sensor starts powering-up after reaching the power-up threshold voltage $V_{DD,min}$ and will take up to the maximum of the sensor startup time, specified in **Table 1**, to enter the idle state. Once the idle state has been reached, it is ready to receive commands from the controller. Any incoming command will be acknowledged (address header and all data bytes). After the stop condition, the sensor validates and processes the received data. During this time, the sensor does not acknowledge any I²C requests (address header will be NACK'd). As soon as the command is fully processed, the I²C interface becomes ready again. The controller can then either read the result with a read operation or send the next command with a write operation.

The processing time depends on the sent command, see **Table 18**. The specified timings are absolute maximum values. If you want to read the response data or send the next command as soon as possible (i.e. without waiting the maximum specified processing time), you could send the next address header multiple times until the sensor acknowledges it.

5.5 Data Type & Length

Applies to: SEN60, SEN63C, SEN65, SEN66, SEN68

Data sent to and received from the sensor consists of a sequence of 16-bit words, most significant byte (MSB) transmitted first. Each word is succeeded by an 8-bit CRC. See **Figure 7** for more detail. In write direction it is mandatory to transmit the checksum. In read direction it is up to the controller to decide whether to process the checksum.

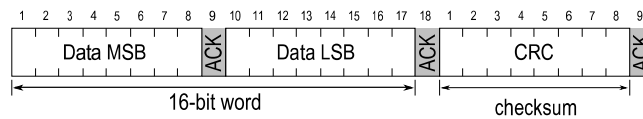

Figure 7. Data type structure with 16-bit word and 8-bit CRC

Please note that the CRC is used only for the 16-bit data packets. The 16-bit command ID itself already contains a 3-bit CRC and therefore no CRC must be appended to it as seen in **Figure 8**. Each command ID is represented by a 4-digit Hex. Code as seen in **Table 18**.

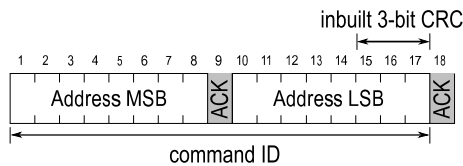

Figure 8. Command ID with inbuilt 3-bit CRC

5.6 Command Sequence Types

The SEN6x features four different I²C command sequence types: write I²C sequences, send I²C command sequence, read I²C sequences and send & fetch I²C sequence. **Figure 9** illustrates how the I²C communication for the different sequence types is built up. For detailed information on the I²C protocol, refer to NXP I²C-bus specification [1].

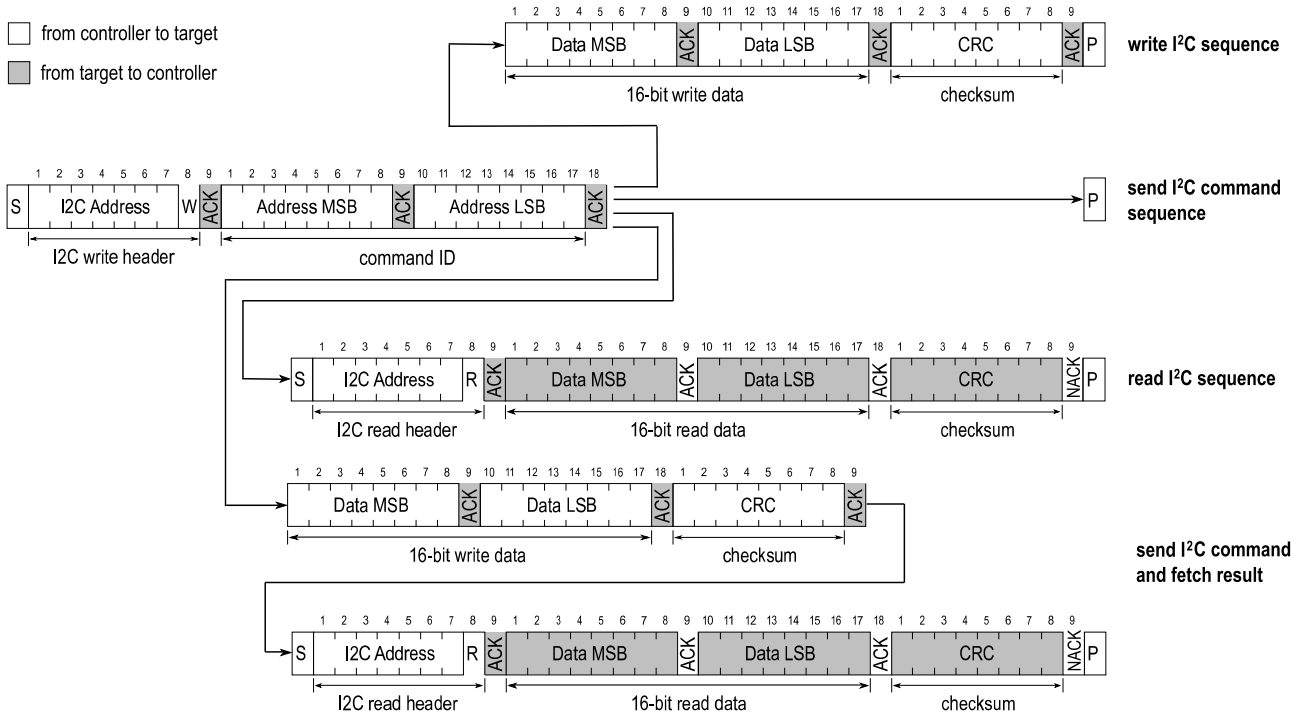

Figure 9. Command sequence types: write sequence, send command sequence, read sequence and send command and fetch result sequence.

After issuing read sequence commands and sending the ACK Bit, the sensor needs the *execution time* (see **Table 18**) to respond to the I²C read header with an ACK bit. Hence, it is required to wait the command execution time before issuing the read header. Commands must not be sent while a previous command is being processed.

5.7 I²C Commands

Applies to: SEN60, SEN63C, SEN65, SEN66, SEN68

Note: SEN60 and SEN68 specific commands will be added in a future update

Comm and ID	Command	I ² C Sequence Type (see Section 5.6)	Execution		Applicable to				
			Time [ms]	During Measur.	SEN60	SEN63C	SEN65	SEN66	SEN68
0x0021	Start Continuous Measurement	send	50	no	-	✓	✓	✓	✓
0x0104	Stop Measurement	send	1100	yes	-	✓	✓	✓	✓
0x0202	Get Data Ready	read	20	yes	-	✓	✓	✓	✓
0x0300	Read Measured Values SEN66	read	20	yes	-	-	-	✓	-
0x0316	Read Number Concentration Values	read	20	yes	-	✓	✓	✓	✓
0x0405	Read Measured Raw Values SEN66	read	20	yes	-	-	-	✓	-
0x5607	Start Fan Cleaning	send	20	no	-	✓	✓	✓	✓
0x60B2	Set Temperature Offset Parameters	write	20	yes	-	✓	✓	✓	✓
0x60D0	Get VOC Algorithm Tuning Parameters	read	20	no	-	-	✓	✓	✓
0x60D0	Set VOC Algorithm Tuning Parameters	write	20	no	-	-	✓	✓	✓
0x60E1	Get NO _x Algorithm Tuning Parameters	read	20	no	-	-	✓	✓	✓
0x60E1	Set NO _x Algorithm Tuning Parameters	write	20	no	-	-	✓	✓	✓
0x6100	Set Temperature Acceleration Parameters	write	20	no	-	✓	✓	✓	✓
0x6181	Get VOC Algorithm State	read	20	yes	-	-	✓	✓	✓
0x6181	Set VOC Algorithm State	write	20	yes	-	-	✓	✓	✓
0x6707	Perform Forced CO ₂ Recalibration	send and fetch	500	no	-	✓	-	✓	-
0x6711	Get CO ₂ Sensor Automatic Self Calibration	read	20	no	-	✓	-	✓	-
0x6711	Set CO ₂ Sensor Automatic Self Calibration	write	20	no	-	✓	-	✓	-
0x6720	Get Ambient Pressure	read	20	yes	-	✓	-	✓	-
0x6720	Sets Ambient Pressure	write	20	yes	-	✓	-	✓	-
0x6736	Get Sensor Altitude	read	20	yes	-	✓	-	✓	-
0x6736	Set Sensor Altitude	write	20	yes	-	✓	-	✓	-
0x6765	Activate SHT Heater	send	1300	no	-	✓	✓	✓	✓
0xD014	Get Product Name	read	20	yes	-	✓	✓	✓	✓
0xD033	Get Serial Number	read	20	yes	-	✓	✓	✓	✓
0xD100	Get Version	read	20	yes	-	✓	✓	✓	✓
0xD206	Read Device Status	read	20	yes	-	✓	✓	✓	✓
0xD210	Read And Clear Device Status	read	20	yes	-	✓	✓	✓	✓
0xD304	Device Reset	send	20	yes	-	✓	✓	✓	✓

Table 18. Command overview. The column ('During measurement') indicates whether the command can be executed while a measurement is running.

5.7.1 Start Continuous Measurement

Applies to: SEN63C, SEN65, SEN66, SEN68

Description: Starts a continuous measurement. After starting the measurement, it takes some time (~1.1s) until the first measurement results are available. You could poll with the command **Get Data Ready** to check when the results are ready to read.

This command is only available in idle mode. If the device is already in any measure mode, this command has no effect.

Start Continuous Measurement	
Command ID	0x0021
Post Processing Time	50 ms
Max. RX Data With CRC	0 Bytes
TX Data	None
RX Data	None

Table 19. Start continuous measurement I²C command description

5.7.2 Stop Measurement

Applies to: SEN63C, SEN65, SEN66, SEN68

Description: Stops the measurement and returns to idle mode. After sending this command, wait at least 1000 ms before starting a new measurement.

If the device is already in idle mode, this command has no effect.

Stop Measurement	
Command ID	0x0104
Post Processing Time	1100 ms
Max. RX Data With CRC	0 Bytes
TX Data	None
RX Data	None

Table 20. Stop measurement I²C command description

5.7.3 Get Data Ready

Applies to: SEN63C, SEN65, SEN66, SEN68

Description: This command can be used to check if new measurement results are ready to read. The data ready flag is automatically reset after reading the measurement values.

Get Data Ready		
Command ID	0x0202	
Read Delay	20 ms	
Post Processing Time	0 ms	
Max. RX Data With CRC	3 Bytes	
TX Data	None	
RX Data	Byte #	Description
	0	Padding: uint8 Padding byte, always 0x00.
	1	Data Ready: bool True (0x01) if data is ready, False (0x00) if not. When no measurement is running, False will be returned.
	2	CRC CRC for the previous two bytes.

Table 21. Get data ready I²C command description

5.7.4 Read Measured Values SEN66

Applies to: SEN66

Description: Returns the measured values. The command **Get Data Ready** can be used to check if new data is available since the last read operation. If no new data is available, the previous values will be returned. If no data is available at all (e.g. measurement not running for at least one second), all values will be at their upper limit (0xFFFF for uint16, 0x7FFF for int16).

Read Measured Values SEN66		
Command ID	0x0300	
Read Delay	20 ms	
Post Processing Time	0 ms	
Max. RX Data With CRC	27 Bytes	
TX Data	None	
RX Data	Byte #	Description
	0	MSB
	1	LSB
	2	CRC
	3	MSB
	4	LSB
	5	CRC
	6	MSB
	7	LSB
	8	CRC
	9	MSB
	10	LSB
	11	CRC
	12	MSB
	13	LSB
	14	CRC
	15	MSB
	16	LSB
	17	CRC
	18	MSB
	19	LSB
	20	CRC
	21	MSB
	22	LSB
	23	CRC
	24	MSB
	25	LSB
26	CRC	

Table 22. Read measured values SEN66 I²C command description

5.7.5 Read Number Concentration Values

Applies to: SEN63C, SEN65, SEN66, SEN68

Description: Returns the measured number concentration values. The command **Get Data Ready** can be used to check if new data is available since the last read operation. If no new data is available, the previous values will be returned. If no data is available at all (e.g. measurement not running for at least one second), all values will be at their upper limit (0xFFFF for uint16).

Read Number Concentration Values			
Command ID	0x0316		
Read Delay	20 ms		
Post Processing Time	0 ms		
Max. RX Data With CRC	15 Bytes		
TX Data			
RX Data	Byte #		Description
	0	MSB	Number Concentration PM0.5: uint16
	1	LSB	Value is scaled with factor 10: PM0.5 [particles/cm ³] = value / 10
	2	CRC	<i>Note: If this value is unknown, 0xFFFF is returned.</i>
	3	MSB	Number Concentration PM1.0: uint16
	4	LSB	Value is scaled with factor 10: PM1.0 [particles/cm ³] = value / 10
	5	CRC	<i>Note: If this value is unknown, 0xFFFF is returned.</i>
	6	MSB	Number Concentration PM2.5: uint16
	7	LSB	Value is scaled with factor 10: PM2.5 [particles/cm ³] = value / 10
	8	CRC	<i>Note: If this value is unknown, 0xFFFF is returned.</i>
	9	MSB	Number Concentration PM4.0: uint16
	10	LSB	Value is scaled with factor 10: PM4.0 [particles/cm ³] = value / 10
	11	CRC	<i>Note: If this value is unknown, 0xFFFF is returned.</i>
	12	MSB	Number Concentration PM10.0: uint16
	13	LSB	Value is scaled with factor 10: PM10.0 [particles/cm ³] = value / 10
14	CRC	<i>Note: If this value is unknown, 0xFFFF is returned.</i>	

Table 23. Read number concentration values I²C command description

5.7.6 Read Measured Raw Values SEN66

Applies to: SEN66

Description: Returns the measured raw values. The command **Get Data Ready** can be used to check if new data is available since the last read operation. If no new data is available, the previous values will be returned. If no data is available at all (e.g. measurement not running for at least one second), all values will be at their upper limit (0xFFFF for uint16, 0x7FFF for int16).

Read Measured Raw Values			
Command ID	0x0405		
Read Delay	20 ms		
Post Processing Time	0 ms		
Max. RX Data With CRC	15 Bytes		
TX Data	None		
RX Data	Byte #		Description
	0	MSB	Raw Humidity: int16
	1	LSB	Value is scaled with factor 100: RH [%] = value / 100
	2	CRC	<i>Note: If this value is unknown, 0x7FFF is returned.</i>
	3	MSB	Raw Temperature: int16
	4	LSB	Value is scaled with factor 200: T [°C] = value / 200
	5	CRC	<i>Note: If this value is unknown, 0x7FFF is returned.</i>
	6	MSB	Raw VOC: uint16
	7	LSB	Raw measured VOC ticks without scale factor.
	8	CRC	<i>Note: If this value is unknown, 0xFFFF is returned.</i>
	9	MSB	Raw NOx: uint16
	10	LSB	Raw measured NOx ticks without scale factor.
	11	CRC	<i>Note: If this value is unknown, 0xFFFF is returned. During the first 10..11 seconds after power-on or device reset, this value will be 0xFFFF as well.</i>
	12	MSB	Raw CO2: uint16
	13	LSB	Not interpolated CO2 concentration [ppm] updated every five seconds.
14	CRC	<i>Note: If this value is unknown, 0xFFFF is returned. During the first 5..6 seconds after power-on or device reset, this value will be 0xFFFF as well.</i>	

Table 24. Read measured raw values SEN66 I²C command description

5.7.7 Start Fan Cleaning

Applies to: SEN63C, SEN65, SEN66, SEN68

Description: This command triggers fan cleaning. The fan is set to the maximum speed for 10 seconds and then automatically stopped. This command is only available in idle mode. Wait at least 10s after this command before starting a measurement.

Start Fan Cleaning	
Command ID	0x5607
Post Processing Time	20 ms
Max. RX Data With CRC	0 Bytes
TX Data	None
RX Data	None

Table 25. Start fan cleaning I²C command description

5.7.8 Set Temperature Offset Parameters

Applies to: SEN63C, SEN65, SEN66, SEN68

Description: This command allows to compensate temperature effects of the design-in at customer side by applying custom temperature offsets to the ambient temperature. The compensated ambient temperature is calculated as follows:

$$T_Ambient_Compensated = T_Ambient + (slope * T_Ambient) + offset$$

Where slope and offset are the values set with this command, smoothed with the specified time constant. All temperatures (T_Ambient_Compensated, T_Ambient and offset) are represented in °C. There are 5 temperature offset slots available that all contribute additively to T_Ambient_Compensated. The default values for the temperature offset parameters are all zero, meaning that T_Ambient_Compensated is equal to T_Ambient by default. The parameters can be changed in any state of the device, i.e. both in idle mode and in measure mode. For more details on how to compensate the temperature on the SEN6x platform, refer to "Temperature Acceleration and Compensation Instructions for SEN6x" [2].

Note: This configuration is volatile, i.e. the parameters will be reverted to their default value of zero after a device reset.

Set Temperature Offset Parameters			
Command ID	0x60B2		
Post Processing Time	20 ms		
Max. RX Data With CRC	0 Bytes		
TX Data	Byte #		
	0	MSB	Offset: int16
	1	LSB	Constant temperature offset scaled with factor 200 (T [°C] = value / 200).
	2	CRC	
	3	MSB	Slope: int16
	4	LSB	Normalized temperature offset slope scaled with factor 10000 (applied factor = value / 10000).
	5	CRC	
	6	MSB	Time Constant: uint16
	7	LSB	The time constant determines how fast the new slope and offset will be applied. After the specified value in seconds, 63% of the new slope and offset are applied. A time constant of zero means the new values will be applied immediately (within the next measure interval of 1 second).
	8	CRC	
	9	MSB	
10	LSB	The temperature offset slot to be modified. Valid values are 0 .. 4. If the value is outside this range, the parameters will not be applied.	
11	CRC		
RX Data	None		

Table 26. Set temperature offset parameters I²C command description

5.7.9 Get VOC Algorithm Tuning Parameters

Applies to: SEN65, SEN66, SEN68

Description: Gets the parameters to customize the VOC algorithm.

Get VOC Algorithm Tuning Parameters			
Command ID	0x60D0		
Read Delay	20 ms		
Post Processing Time	0 ms		
Max. RX Data With CRC	18 Bytes		
TX Data	None		
RX Data	Byte #		Description
	0	MSB	Index Offset: <code>int16</code> VOC index representing typical (average) conditions.
	1	LSB	
	2	CRC	
	3	MSB	Learning Time Offset Hours: <code>int16</code> Time constant to estimate the VOC algorithm offset from the history in hours. Past events will be forgotten after about twice the learning time.
	4	LSB	
	5	CRC	
	6	MSB	Learning Time Gain Hours: <code>int16</code> Time constant to estimate the VOC algorithm gain from the history in hours. Past events will be forgotten after about twice the learning time.
	7	LSB	
	8	CRC	
	9	MSB	Gating Max Duration Minutes: <code>int16</code> Maximum duration of gating in minutes (freeze of estimator during high VOC index signal). Zero disables the gating.
	10	LSB	
	11	CRC	
	12	MSB	Std Initial: <code>int16</code> Initial estimate for standard deviation. Lower value boosts events during initial learning period but may result in larger device-to-device variations.
	13	LSB	
	14	CRC	
	15	MSB	Gain Factor: <code>int16</code> Gain factor to amplify or to attenuate the VOC index output.
16	LSB		
17	CRC		

Table 27. Get VOC algorithm tuning parameters I²C command description

5.7.10 Set VOC Algorithm Tuning Parameters

Applies to: SEN65, SEN66, SEN68

Description: Sets the parameters to customize the VOC algorithm. This command is available only in idle mode. In measure mode, this command has no effect. In addition, it has no effect if at least one parameter is outside the specified range.

This configuration is volatile, i.e. the parameters will be reverted to their default values after a device reset.

Set VOC Algorithm Tuning Parameters			
Command ID	0x60D0		
Post Processing Time	20 ms		
Max. RX Data With CRC	0 Bytes		
TX Data	Byte #	Description	
	0	MSB	Index Offset: int16 Range: 1..250
	1	LSB	VOC index representing typical (average) conditions. Allowed values are in range 1..250. The default value is 100.
	2	CRC	
	3	MSB	Learning Time Offset Hours: int16 Range: 1..1000 Time constant to estimate the VOC algorithm offset from the history in hours. Past events will be forgotten after about twice the learning time. Allowed values are in range 1..1000. The default value is 12 hours.
	4	LSB	
	5	CRC	
	6	MSB	Learning Time Gain Hours: int16 Range: 1..1000 Time constant to estimate the VOC algorithm gain from the history in hours. Past events will be forgotten after about twice the learning time. Allowed values are in range 1..1000. The default value is 12 hours.
	7	LSB	
	8	CRC	
	9	MSB	Gating Max Duration Minutes: int16 Range: 0..3000 Maximum duration of gating in minutes (freeze of estimator during high VOC index signal). Set to zero to disable the gating. Allowed values are in range 0..3000. The default value is 180 minutes.
	10	LSB	
	11	CRC	
	12	MSB	Std Initial: int16 Range: 10..5000 Initial estimate for standard deviation. Lower value boosts events during initial learning period but may result in larger device-to-device variations. Allowed values are in range 10..5000. The default value is 50.
	13	LSB	
	14	CRC	
	15	MSB	Gain Factor: int16 Range: 1..1000 Gain factor to amplify or to attenuate the VOC index output. Allowed values are in range 1..1000. The default value is 230.
16	LSB		
17	CRC		
RX Data	None		

Table 28. Set VOC algorithm tuning parameters I²C command description

5.7.11 Get NO_x Algorithm Tuning Parameters

Applies to: SEN65, SEN66, SEN68

Description: Gets the parameters to customize the NO_x algorithm.

Get NO _x Algorithm Tuning Parameters			
Command ID	0x60E1		
Read Delay	20 ms		
Post Processing Time	0 ms		
Max. RX Data With CRC	18 Bytes		
TX Data	None		
RX Data	Byte #		Description
	0	MSB	Index Offset: <code>int16</code> NO _x index representing typical (average) conditions.
	1	LSB	
	2	CRC	
	3	MSB	Learning Time Offset Hours: <code>int16</code> Time constant to estimate the NO _x algorithm offset from the history in hours. Past events will be forgotten after about twice the learning time.
	4	LSB	
	5	CRC	
	6	MSB	Learning Time Gain Hours: <code>int16</code> The time constant to estimate the NO _x algorithm gain from the history has no impact for NO _x . This parameter is still in place for consistency reasons with the VOC tuning parameters command.
	7	LSB	
	8	CRC	
	9	MSB	Gating Max Duration Minutes: <code>int16</code> Maximum duration of gating in minutes (freeze of estimator during high NO _x index signal). Zero disables the gating.
	10	LSB	
	11	CRC	
	12	MSB	Std Initial: <code>int16</code> The initial estimate for standard deviation has no impact for NO _x . This parameter is still in place for consistency reasons with the VOC tuning parameters command.
	13	LSB	
	14	CRC	
	15	MSB	Gain Factor: <code>int16</code> Gain factor to amplify or to attenuate the NO _x index output.
16	LSB		
17	CRC		

Table 29. Get NO_x algorithm tuning parameters I²C command description

5.7.12 Set NOx Algorithm Tuning Parameters

Applies to: SEN65, SEN66, SEN68

Description: Sets the parameters to customize the NOx algorithm. This command is available only in idle mode. In measure mode, this command has no effect. In addition, it has no effect if at least one parameter is outside the specified range.

This configuration is volatile, i.e. the parameters will be reverted to their default values after a device reset.

Set NOx Algorithm Tuning Parameters		
Command ID	0x60E1	
Post Processing Time	20 ms	
Max. RX Data With CRC	0 Bytes	
TX Data	Byte #	Description
	0	MSB
	1	LSB
	2	CRC
	3	MSB
	4	LSB
	5	CRC
	6	MSB
	7	LSB
	8	CRC
	9	MSB
	10	LSB
	11	CRC
	12	MSB
	13	LSB
	14	CRC
	15	MSB
16	LSB	
17	CRC	
RX Data	None	

Table 30. Set NO_x algorithm tuning parameters I²C command description

5.7.13 Set Temperature Acceleration Parameters

Applies to: SEN63C, SEN65, SEN66, SEN68

Description: This command allows to set custom temperature acceleration parameters of the RH/T engine. Overwrites the default temperature acceleration parameters of the RH/T engine with custom values. The parameters can only be set in idle mode. This configuration is volatile, *i.e.* the parameters will be reverted to their default values after a device reset.

For more details on how to compensate the temperature on the SEN6x platform, refer to “Temperature Acceleration and Compensation Instructions for SEN6x” [2].

Set Temperature Acceleration Parameters		
Command ID	0x6100	
Post Processing Time	20 ms	
Max. RX Data With CRC	0 Bytes	
TX Data	Byte #	
	0	MSB
	1	LSB
	2	CRC
	K: uint16	
	Filter constant K scaled with factor 10 (K = value / 10).	
	3	MSB
	4	LSB
	5	CRC
	P: uint16	
	Filter constant P scaled with factor 10 (P = value / 10).	
	6	MSB
7	LSB	
8	CRC	
T1: uint16		
Time constant T1 scaled with factor 10 (T1 [s] = value / 10).		
9	MSB	
10	LSB	
11	CRC	
T2: uint16		
Time constant T2 scaled with factor 10 (T2 [s] = value / 10).		
RX Data	None	

Table 31. Set temperature acceleration parameters I²C command description

5.7.14 Get VOC Algorithm State

Applies to: SEN65, SEN66, SEN68

Description: Allows backup of the VOC algorithm state to resume operation after a power cycle or device reset, skipping initial learning phase. By default, the VOC Engine is reset, and the algorithm state is retained if a measurement is stopped and started again. If the VOC algorithm state shall be reset, a device reset, or a power cycle can be executed.

Gets the current VOC algorithm state. This data can be used to restore the state with the **Set VOC Algorithm State** command after a short power cycle or device reset.

This command can be used either in measure mode or in idle mode (which will then return the state at the time when the measurement was stopped). In measure mode, the state can be read each measure interval to always have the latest state available, even in case of a sudden power loss.

Get VOC Algorithm State			
Command ID	0x6181		
Read Delay	20 ms		
Post Processing Time	0 ms		
Max. RX Data With CRC	12 Bytes		
TX Data	None		
RX Data	Byte #		Description
	0	Byte 0	
	1	Byte 1	
	2	CRC	
	
	9	Byte 6	
	10	Byte 7	
11	CRC	State: bytearray<8> Current VOC algorithm state.	

Table 32. Get VOC algorithm state I²C command description

5.7.15 Set VOC Algorithm State

Applies to: SEN65, SEN66, SEN68

Description: Allows restoration of the VOC algorithm state to resume operation after a power cycle or device reset, skipping initial learning phase. By default, the VOC Engine is reset, and the algorithm state is retained if a measurement is stopped and started again. If the VOC algorithm state shall be reset, a device reset, or a power cycle can be executed.

Sets the VOC algorithm state previously received with the **Get VOC Algorithm State** command. This command is only available in idle mode and the state will be applied only once when starting the next measurement. In measure mode, this command has no effect.

Set VOC Algorithm State			
Command ID	0x6181		
Post Processing Time	20 ms		
Max. RX Data With CRC	0 Bytes		
TX Data	Byte #		Description
	0	Byte 0	
	1	Byte 1	
	2	CRC	
	
	9	Byte 6	
	10	Byte 7	
	11	CRC	State: bytearray<8> VOC algorithm state to restore.
RX Data	None		

Table 33. Set VOC algorithm state I²C command description

5.7.16 Perform Forced CO₂ Recalibration

Applies to: SEN63C, SEN66

Description: Execute the forced recalibration (FRC) of the CO₂ signal. See the datasheet of the SCD4x sensor for details how the forced recalibration shall be used [3].

Note: After power-on wait at least 1000 ms and after stopping a measurement 600 ms before sending this command. This command is not available in measure mode. The recalibration procedure will take about 500 ms to complete, during which time no other functions can be executed.

Perform Forced CO2 Recalibration			
Command ID	0x6707		
Read Delay	500 ms		
Post Processing Time	0 ms		
Max. RX Data With CRC	3 Bytes		
TX Data	Byte #		Description
	0	MSB	
	1	LSB	
	2	CRC	
			Target CO ₂ Concentration: uint16 Target CO ₂ concentration [ppm] of the test setup.
RX Data	Byte #		Description
	0	MSB	
	1	LSB	
	2	CRC	
			Correction: uint16 Correction value as received from the SCD [ppm CO ₂]. FRC correction [ppm CO ₂] is return value - 0x8000, if the recalibration has failed this value is 0xFFFF.

Table 34. Perform forced CO₂ recalibration I²C command description

5.7.17 Get CO₂ Sensor Automatic Self Calibration

Applies to: SEN63C, SEN66

Description: Gets the status of the CO₂ sensor automatic self-calibration (ASC). The CO₂ sensor supports automatic self-calibration (ASC) for long-term stability of the CO₂ output. This feature can be enabled or disabled. By default, it is enabled.

This command is not available in measure mode. This configuration is volatile, i.e. the parameter will be reverted to its default value after a device restart.

Get CO2 Sensor Automatic Self Calibration		
Command ID	0x6711	
Read Delay	20 ms	
Post Processing Time	0 ms	
Max. RX Data With CRC	3 Bytes	
TX Data	None	
RX Data	Byte #	Description
	0	Padding: uint8 Padding byte, always 0x00.
	1	Status: bool Is set true (0x01) if the automatic self-calibration is enabled or false (0x00) if the automatic self-calibration is disabled.
	2	CRC CRC for the previous two bytes.

Table 35. Get CO₂ sensor automatic self calibration I²C command description

5.7.18 Set CO₂ Sensor Automatic Self Calibration

Applies to: SEN63C, SEN66

Description: Sets the status of the CO₂ sensor automatic self-calibration (ASC). The CO₂ sensor supports automatic self-calibration (ASC) for long-term stability of the CO₂ output. This feature can be enabled or disabled. By default, it is enabled.

This command is not available in measure mode. This configuration is volatile, i.e. the parameter will be reverted to its default value after a device restart.

Set CO2 Sensor Automatic Self Calibration		
Command ID	0x6711	
Post Processing Time	20 ms	
Max. RX Data With CRC	0 Bytes	
TX Data	Byte #	Description
	0	Padding: uint8 Padding byte, always 0x00.
	1	Status: bool Set to true (0x01) to enable or false (0x00) to disable the automatic CO2 measurement self-calibration feature.
	2	CRC CRC for the previous two bytes.
RX Data	None	

Table 36. Set CO₂ sensor automatic self-calibration I²C command description

5.7.19 Get Ambient Pressure

Applies to: SEN63C, SEN66

Description: Gets the ambient pressure value. The ambient pressure can be used for pressure compensation in the CO₂ sensor. This command can be used in any state of the device, i.e. both in idle mode and in measure mode.

Get Ambient Pressure			
Command ID	0x6720		
Read Delay	20 ms		
Post Processing Time	0 ms		
Max. RX Data With CRC	3 Bytes		
TX Data	None		
RX Data	Byte #		Description
	0	MSB	Ambient Pressure: uint16
	1	LSB	Currently used ambient pressure [hPa] for pressure compensation.
	2	CRC	

Table 37. Get ambient pressure I²C command description

5.7.20 Sets Ambient Pressure

Applies to: SEN63C, SEN66

Description: Sets the ambient pressure value. The ambient pressure can be used for pressure compensation in the CO₂ sensor. Setting an ambient pressure overrides any pressure compensation based on a previously set sensor altitude. Use of this command is recommended for applications experiencing significant ambient pressure changes to ensure CO₂ sensor accuracy. Valid input values are between 700 to 1'200 hPa. The default value is 1013 hPa. This command can be used in any state of the device, i.e. both in idle mode and in measure mode.

This configuration is volatile, i.e. the parameter will be reverted to its default value after a device restart.

Set Ambient Pressure			
Description	Sets ambient pressure value.		
Command ID	0x6720		
Post Processing Time	20 ms		
Max. RX Data With CRC	0 Bytes		
TX Data	Byte #		Description
	0	MSB	Ambient Pressure: uint16
	1	LSB	Ambient pressure [hPa] to be used for pressure compensation.
	2	CRC	
RX Data	None		

Table 38. Set ambient pressure I²C command description

5.7.21 Get Sensor Altitude

Applies to: SEN63C, SEN66

Description: Gets the current sensor altitude. The sensor altitude can be used for pressure compensation in the CO₂ sensor. Getting the sensor altitude must be done in idle mode. The default sensor altitude value is set to 0 meters above sea level. Valid input values are between 0 and 3000m.

Get Sensor Altitude			
Command ID	0x6736		
Read Delay	20 ms		
Post Processing Time	0 ms		
Max. RX Data With CRC	3 Bytes		
TX Data	None		
RX Data	Byte #		Description
	0	MSB	Altitude: uint16 Current sensor altitude [m].
	1	LSB	
	2	CRC	

Table 39. Get sensor altitude I²C command description

5.7.22 Set Sensor Altitude

Applies to: SEN63C, SEN66

Description: Sets the current sensor altitude. The sensor altitude can be used for pressure compensation in the CO₂ sensor. Setting the sensor altitude must be done in idle mode. The default sensor altitude value is set to 0 meters above sea level. Valid input values are between 0 and 3000m.

This configuration is volatile, i.e. the parameter will be reverted to its default value after a device reset.

Set Sensor Altitude			
Command ID	0x6736		
Post Processing Time	20 ms		
Max. RX Data With CRC	0 Bytes		
TX Data	Byte #		Description
	0	MSB	Altitude: uint16 Sensor altitude [m], valid input between 0 and 3000m.
	1	LSB	
	2	CRC	
RX Data	None		

Table 40. Set sensor altitude I²C command description

5.7.23 Activate SHT Heater

Applies to: SEN63C, SEN65, SEN66, SEN68

Description: This command allows you to use the inbuilt heater in SHT sensor to reverse creep at high humidity. This command activates the SHT sensor heater with 200mW for 1s. The heater is then automatically deactivated again.

This command is only available in idle mode. Wait at least 20s after this command before starting a measurement to get coherent temperature values (heating consequence to disappear).

Activate SHT Heater	
Command ID	0x6765
Post Processing Time	1300 ms
Max. RX Data With CRC	0 Bytes
TX Data	None
RX Data	None

Table 41. Activate SHT heater I²C command description

5.7.24 Get Product Name

Applies to: SEN63C, SEN65, SEN66, SEN68

Description: Gets the product name from the device.

Get Product Name			
Command ID	0xD014		
Read Delay	20 ms		
Post Processing Time	0 ms		
Max. RX Data With CRC	48 Bytes		
TX Data	None		
RX Data	Byte #		Description
	0	Char 0	
	1	Char 1	
	2	CRC	
	
	45	Char 30	
	46	Char 31	
47	CRC		

Product Name: string<32>
Null-terminated ASCII string containing the product name. Up to 32 characters can be read from the device.

Table 42. Get product name I²C command description

5.7.25 Get Serial Number

Applies to: SEN63C, SEN65, SEN66, SEN68

Description: Gets the serial number from the device.

Get Serial Number			
Command ID	0xD033		
Read Delay	20 ms		
Post Processing Time	0 ms		
Max. RX Data With CRC	48 Bytes		
TX Data	None		
RX Data	Byte #		Description
	0	Char 0	
	1	Char 1	
	2	CRC	
	
	45	Char 30	
	46	Char 31	
47	CRC		

Table 43.Get serial number I²C command description

5.7.26 Get Version

Applies to: SEN63C, SEN65, SEN66, SEN68

Description: Gets the version information for the hardware, firmware and communication protocol.

Get Version		
Command ID	0xD100	
Read Delay	20 ms	
Post Processing Time	0 ms	
Max. RX Data With CRC	12 Bytes	
TX Data	None	
RX Data	Byte #	Description
	0	- Firmware Major: uint8 Firmware major version number.
	1	- Firmware Minor: uint8 Firmware minor version number.
	2	CRC CRC for the previous two bytes.
	3	- Firmware Debug: bool Firmware debug state. If the debug state is set, the firmware is in development.
	4	- Hardware Major: uint8 Hardware major version number.
	5	CRC CRC for the previous two bytes.
	6	- Hardware Minor: uint8 Hardware minor version number.
	7	- Protocol Major: uint8 Protocol major version number.
	8	CRC CRC for the previous two bytes.
	9	- Protocol Minor: uint8 Protocol minor version number.
	10	- Padding: uint8 Padding byte, ignore this.
11	CRC CRC for the previous two bytes.	

Table 44. Get version I²C command description

5.7.27 Read Device Status

Applies to: SEN63C, SEN65, SEN66, SEN68

Description: Reads the current device status.

Use this command to get detailed information about the device status. The device status is encoded in flags. Each device status flag represents a single bit in a 32-bit integer value. If more than one error is present, the device status register value is the sum of the corresponding flag values. For details about the available flags, refer to the device status flags documentation.

Note: The status flags of type "Error" are sticky, i.e. they are not cleared automatically even if the error condition no longer exists. So, they can only be cleared manually with **Read And Clear Device Status** or with a **Device Reset**. All other flags are not sticky, i.e. they are cleared automatically if the trigger condition disappears.

Read Device Status		
Command ID	0xD206	
Read Delay	20 ms	
Post Processing Time	0 ms	
Max. RX Data With CRC	6 Bytes	
TX Data	None	
RX Data	Byte #	
	0	MSB
	1	-
	2	CRC
	3	-
	4	LSB
5	CRC	
Description		
Device Status: uint32 Device status (32 flags as an integer value). For details, please refer to the device status flags documentation.		

Table 45. Read device status I²C command description

5.7.28 Read And Clear Device Status

Applies to: SEN63C, SEN65, SEN66, SEN68

Description: Reads the current device status (like command **Read Device Status**) and afterwards clears all flags.

Read And Clear Device Status		
Command ID	0xD210	
Read Delay	20 ms	
Post Processing Time	0 ms	
Max. RX Data With CRC	6 Bytes	
TX Data	None	
RX Data	Byte #	
	0	MSB
	1	-
	2	CRC
	3	-
	4	LSB
5	CRC	
Description		
Device Status: uint32 Device status (32 flags as an integer value) before clearing it. For details, please refer to the device status flags documentation.		

Table 46. Read and clear device status I²C command description

5.7.29 Device Reset

Applies to: SEN63C, SEN65, SEN66, SEN68

Description: Executes a reset on the device. This has the same effect as a power cycle.

Device Reset	
Command ID	0xD304
Post Processing Time	1200 ms
Max. RX Data With CRC	0 Bytes
TX Data	None
RX Data	None

Table 47. Device reset I²C command description

5.8 Checksum Calculation (CRC)

Applies to: SEN60, SEN63C, SEN65, SEN66, SEN68

The 8-bit CRC checksum transmitted after each data word is generated by a CRC algorithm. Its properties are displayed in **Table 48**. The CRC covers the contents of the two previously transmitted data bytes. To calculate the checksum, only these two previously transmitted data bytes are used. Note that command words are not followed by CRC.

Property	Value	Example code (C/C++)
Name	CRC-8-Dallas/Maxim	<code>#define CRC8_POLYNOMIAL 0x31</code>
Width	8 bits	<code>#define CRC8_INIT 0xFF</code>
Protected Data	read and/or write data	<code>uint8_t sensirion_generate_crc(const uint8_t* data, uint16_t count) {</code>
Polynomial	0x31 ($x^8+x^5+x^4+1$)	<code>uint16_t current_byte;</code>
Initialization	0xFF	<code>uint8_t crc = CRC8_INIT;</code>
Reflect input	No	<code>uint8_t crc_bit;</code>
Reflect output	No	<code>/* calculates 8-Bit checksum with given polynomial */</code>
Final XOR	0x00	<code>for (current_byte = 0; current_byte < count; ++current_byte) {</code>
Examples	CRC (0xBEEF) = 0x92	<code> crc ^= (data[current_byte]);</code>
		<code> for (crc_bit = 8; crc_bit > 0; --crc_bit) {</code>
		<code> if (crc & 0x80)</code>
		<code> crc = (crc << 1) ^ CRC8_POLYNOMIAL;</code>
		<code> else</code>
		<code> crc = (crc << 1);</code>
		<code> }</code>
		<code> }</code>
		<code> return crc;</code>
		<code>}</code>

Table 48. I²C CRC properties

6 Technical Drawing

6.1 Package Outline

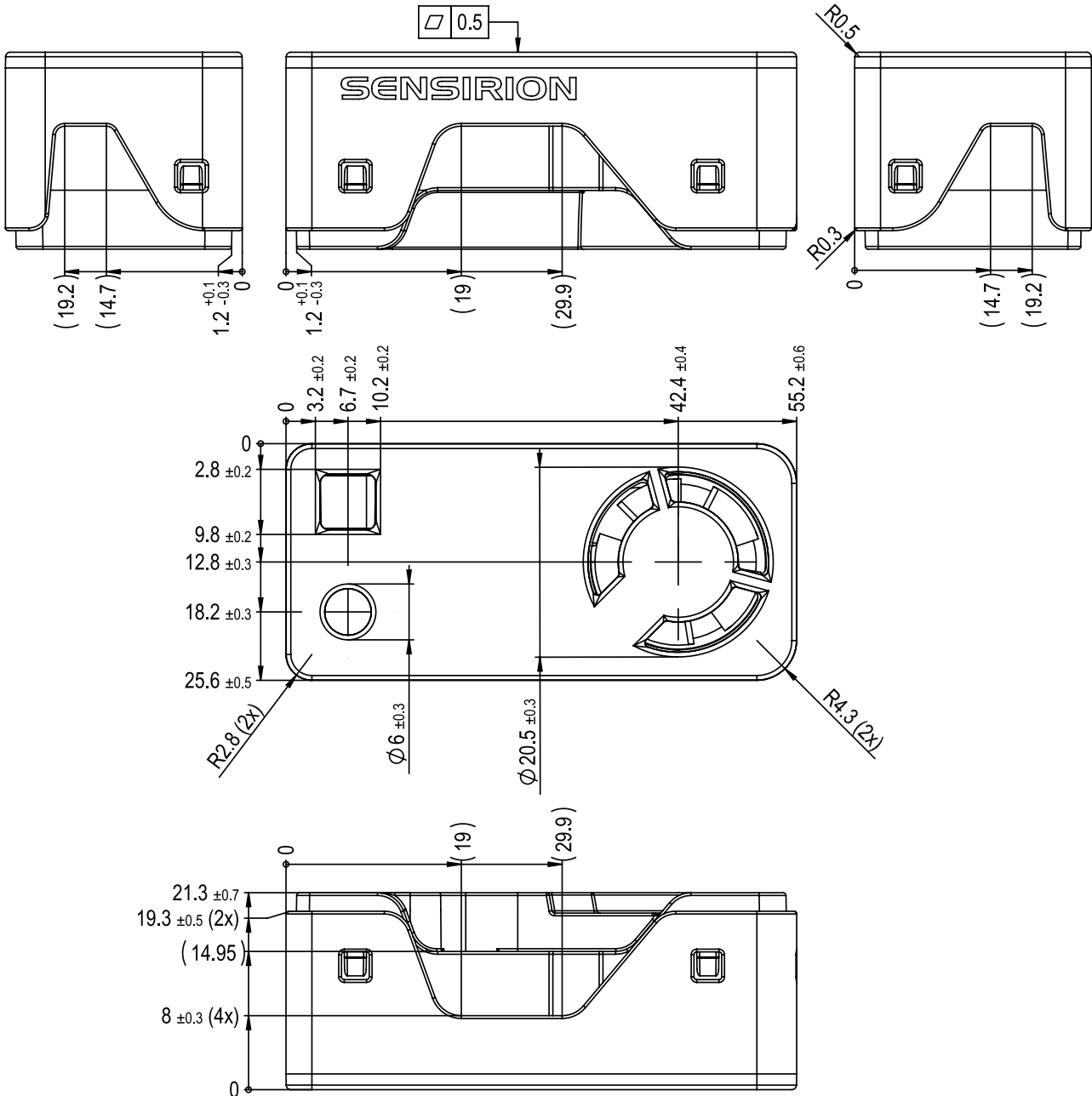

Figure 10. Technical Drawing of the SEN6x platform

6.2 Product Label

All SEN6x sensors include a 22mm x 8mm label as seen in **Figure 11**. For more information on the content, see **Table 49**.

Label Design	Label Content	Description
	QR Code	QR code containing the 16-digit HEX serial number
	SEN6xx-SIN-T	Material description as in Table 50
	EEEEEEEE	First 8 digits of the 16-digit HEX code
	FFFFFFF	Last 8 digits of the 16-digit HEX code

Table 49. Label information

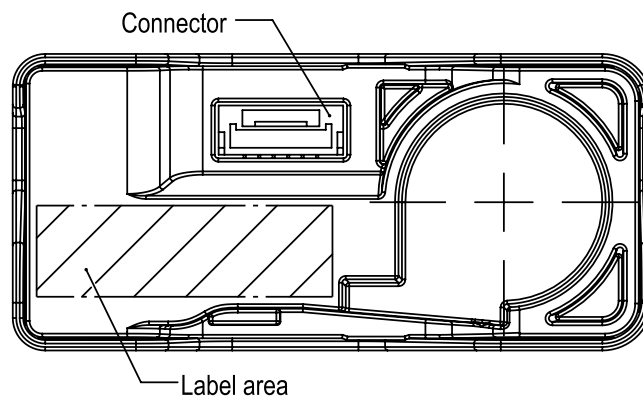

Figure 11. Label position on SEN6x

7 Ordering Information

Material Description	Material Number	Sensor Outputs	Quantity
SEN60-SIN-T	3.001.163	<ul style="list-style-type: none"> • Particulate Matter 	420pcs per box, 7 trays, 60pcs per tray
SEN63C-SIN-T	3.001.197	<ul style="list-style-type: none"> • Particulate Matter • Relative Humidity • Temperature • CO₂ 	420pcs per box, 7 trays, 60pcs per tray
SEN65-SIN-T	3.001.203	<ul style="list-style-type: none"> • Particulate Matter • Relative Humidity • Temperature • VOC Index • NOx Index 	420pcs per box, 7 trays, 60pcs per tray
SEN66-SIN-T	3.001.030	<ul style="list-style-type: none"> • Particulate Matter • Relative Humidity • Temperature • VOC Index • NOx Index • CO₂ 	420pcs per box, 7 trays, 60pcs per tray
SEN68-SIN-T	3.001.198	<ul style="list-style-type: none"> • Particulate Matter • Relative Humidity • Temperature • VOC Index • NOx Index • Formaldehyde 	420pcs per box, 7 trays, 60pcs per tray

Table 50. Ordering information

8 Bibliography

- [1] NXP, "UM10204 I2C-bus specification and user manual Rev.7.0," 1 October 2021. [Online]. Available: <https://www.nxp.com/docs/en/user-guide/UM10204.pdf>. [Accessed 04 October 2024].
- [2] Sensirion, "Temperature Acceleration and Compensation Instructions for SEN6x," October 2024. [Online]. Available: www.sensirion.com.
- [3] Sensirion AG, "Datasheet SCD4x," September 2024. [Online]. Available: www.sensirion.com.
- [4] Sensirion AG, "Sensirion Environmental Node Sensor Specification Statement – Rev.2," November 2024. [Online]. Available: www.sensirion.com.
- [5] Sensirion, "Sensirion Humidity Sensor Specification Statement," 19 April 2021. [Online]. Available: www.sensirion.com. [Accessed 12 October 2024].
- [6] Sensirion, "SGP40 - Quick Testing Guide," March 2021. [Online]. Available: www.sensirion.com. [Accessed 12 October 2024].

9 Revision History

Date	Version	Pages	Changes
March 2023	V0.1	all	Initial version
October 2023	V0.2	all	Update information, switch to 3.3V
July 2024	V0.3	all	Update information, switch to 1x3.3V+-5%
September 2024	V0.4	all	Add ordering information, add technical drawing, add SEN63C
October 2024	V0.5	all	Add Interface description, add label information

Important Notices

Warning, Personal Injury

Do not use this product as safety or emergency stop devices or in any other application where failure of the product could result in personal injury. Do not use this product for applications other than its intended and authorized use. Before installing, handling, using or servicing this product, please consult the data sheet and application notes. Failure to comply with these instructions could result in death or serious injury.

If the Buyer shall purchase or use SENSIRION products for any unintended or unauthorized application, Buyer shall defend, indemnify and hold harmless SENSIRION and its officers, employees, subsidiaries, affiliates and distributors against all claims, costs, damages and expenses, and reasonable attorney fees arising out of, directly or indirectly, any claim of personal injury or death associated with such unintended or unauthorized use, even if SENSIRION shall be allegedly negligent with respect to the design or the manufacture of the product.

ESD Precautions

The inherent design of this component causes it to be sensitive to electrostatic discharge (ESD). To prevent ESD-induced damage and/or degradation, take customary and statutory ESD precautions when handling this product. See application note "ESD, Latchup and EMC" for more information.

Warranty

SENSIRION warrants solely to the original purchaser of this product for a period of 12 months (one year) from the date of delivery that this product shall be of the quality, material and workmanship defined in SENSIRION's published specifications of the product. Within such period, if proven to be defective, SENSIRION shall repair and/or replace this product, in SENSIRION's discretion, free of charge to the Buyer, provided that:

- notice in writing describing the defects shall be given to SENSIRION within fourteen (14) days after their appearance;
- such defects shall be found, to SENSIRION's reasonable satisfaction, to have arisen from SENSIRION's faulty design, material, or workmanship;
- the defective product shall be returned to SENSIRION's factory at the Buyer's expense; and
- the warranty period for any repaired or replaced product shall be limited to the unexpired portion of the original period.

This warranty does not apply to any equipment which has not been installed and used within the specifications recommended by SENSIRION for the intended and proper use of the equipment. EXCEPT FOR THE WARRANTIES EXPRESSLY SET FORTH HEREIN, SENSIRION MAKES NO WARRANTIES, EITHER EXPRESS OR IMPLIED, WITH RESPECT TO THE PRODUCT. ANY AND ALL WARRANTIES, INCLUDING WITHOUT LIMITATION, WARRANTIES OF MERCHANTABILITY OR FITNESS FOR A PARTICULAR PURPOSE, ARE EXPRESSLY EXCLUDED AND DECLINED.

SENSIRION is only liable for defects of this product arising under the conditions of operation provided for in the data sheet and proper use of the goods. SENSIRION explicitly disclaims all warranties, express or implied, for any period during which the goods are operated or stored not in accordance with the technical specifications.

SENSIRION does not assume any liability arising out of any application or use of any product or circuit and specifically disclaims any and all liability, including without limitation consequential or incidental damages. All operating parameters, including without limitation recommended parameters, must be validated for each customer's applications by customer's technical experts. Recommended parameters can and do vary in different applications.

SENSIRION reserves the right, without further notice, (i) to change the product specifications and/or the information in this document and (ii) to improve reliability, functions and design of this product.

Headquarters and Subsidiaries

Sensirion AG

Laubisruetistr. 50
CH-8712 Staefa ZH
Switzerland

phone: +41 44 306 40 00
fax: +41 44 306 40 30
info@sensirion.com
www.sensirion.com

Sensirion Taiwan Co. Ltd

phone: +886 2 2218-6779
info@sensirion.com
www.sensirion.com

Sensirion Inc., USA

phone: +1 312 690 5858
info-us@sensirion.com
www.sensirion.com

Sensirion Japan Co. Ltd.

phone: +81 45 270 4506
info-jp@sensirion.com
www.sensirion.com/jp

Sensirion Korea Co. Ltd.

phone: +82 31 337 7700~3
info-kr@sensirion.com
www.sensirion.com/kr

Sensirion China Co. Ltd.

phone: +86 755 8252 1501
info-cn@sensirion.com
www.sensirion.com/cn

To find your local representative, please visit
www.sensirion.com/distributors