

THIS DOCUMENT IS THE PROPERTY OF  
KEYSTONE ELECTRONICS CORP. AND  
SHALL NOT BE REPRODUCED, DISTRIBUTED  
OR USED AS A BASIS FOR MANUFACTURE  
WITHOUT PRIOR WRITTEN PERMISSION  
FROM KEYSTONE ELECTRONICS CORP.

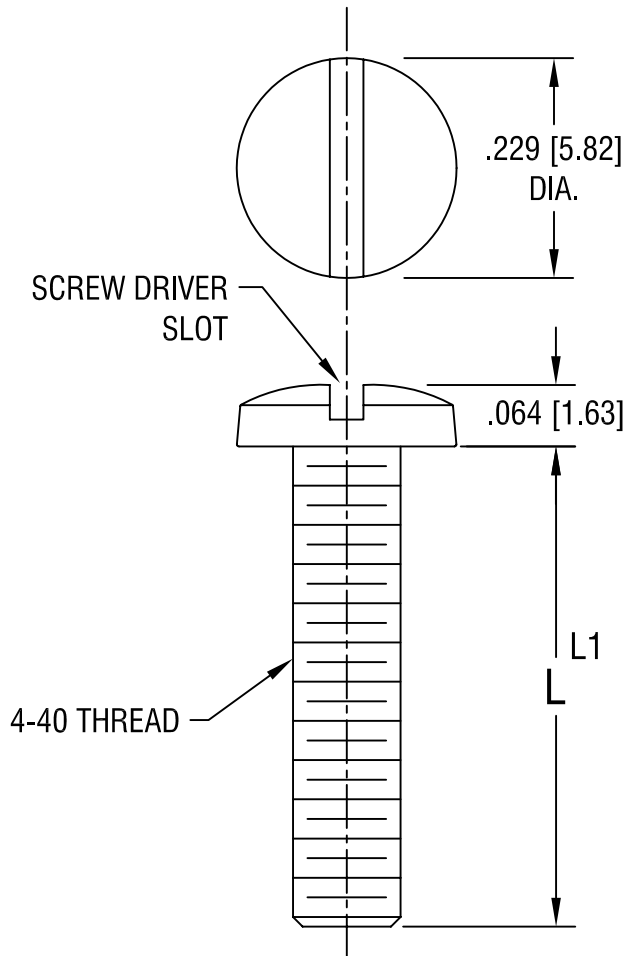

| PART NO. | 'L' DIM.      | 'L1' TOL. +0.0 |
|----------|---------------|----------------|
| 9400     | .250 [6.25]   | -.020 [-0.50]  |
| 9401     | .375 [9.53]   |                |
| 9402     | .500 [12.70]  | -.030 [-0.76]  |
| 9403     | .625 [15.88]  |                |
| 9404     | .750 [19.05]  |                |
| 9405     | 1.000 [25.40] |                |

**KEYSTONE ELECTRONICS CORP.**

ASTORIA, N.Y. 11105-2017

PART NAME

4-40 BINDING HEAD SCREW

MATERIAL

STEEL

FINISH

ZINC PLATE

DRN BY

BOONE

DATE

3.1.04

APPD

LN

SCALE

5X

TOLERANCES

INCH [MM]

DECIMAL  $\pm .010$  [ $\pm 0.25$ ]

ANGULAR  $\pm 1^\circ$

UNLESS OTHERWISE SPECIFIED

CODE

C/M

DWG NO.

9400-9405

DATE

DESCRIPTION

REV.