



IEC Appliance Outlet F, Snap-in Mounting, Front Side, IDC Terminal

new



Arrangement "cross"
(wires cross to pin axis)



Arrangement "along"
(wires along to pin axis)



Arrangement "along", view from rear side
(wires along to pin axis)

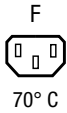

Description

- Panel Mount:
Snap-in version, from front side
- Connector, Pin temperature 70 °C, Protection class I
- Wire gauge 1-1.5mm²/1.5mm²/2.5mm²/14AWG/12AWG
- IDC terminals acc. to IEC 60998-2-3 for solid wires

Approvals

- ENEC File Number: 40035679
- UL File Number: E103791
- CCC File Number: 2010010204418560

Characteristics

- IDC technology for efficient and cost saving mounting
- Protection cover can be used as "wire press"
- Live contact available as IDC, solder or quick connect terminal
- Qualified for use in equipment according IEC/EN 60950

Other versions on request

- UL approval for AWG 16; Versions for other wire gauges
- Protection class II, 70°C

Weblinks

[pdf-datasheet](#), [html-datasheet](#), [General Product Information](#), [Approvals](#), [CE declaration of conformity](#), [RoHS](#), [CHINA-RoHS](#), [Mating Connectors](#), [e-Shop](#), [SCHURTER-Stock-Check](#), [Distributor-Stock-Check](#), [CAD-Drawings](#), [Accessories](#), [Detailed request for product](#)

Newly available variants corresponding to V-Lock mating cordset. The connector is equipped with a notch intended for use with the latching cordset. The cord latching system prevents against accidental removal of the cordset.

Technical Data

Ratings IEC	10A / 250VAC; 50Hz
Ratings UL/CSA	15A / 250VAC; 60Hz
Allowable Operation Temp.	-25 °C to 70 °C
Degree of Protection	from front side IP 40 acc. to IEC 60529
Protection Class	Suitable for appliances with protection class I acc. to IEC 61140
Terminal	IDC terminals
Panel Thickness s	Snap-in, 0.8/1/1.2/1.5/2/2.5/3.0 mm (other on request)
Material: Housing	Thermoplastic, black, UL 94V-0

Appliance Outlet	F acc. to IEC 60320 UL 498, CSA C22.2 no. 42 (for cold conditions) pin-temperature 70 °C, 10A, Protection Class I
------------------	--

Dimensions

Version "cross" (wires cross to pin axis)
L/N/PE: IDC terminals

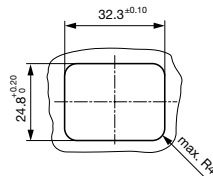
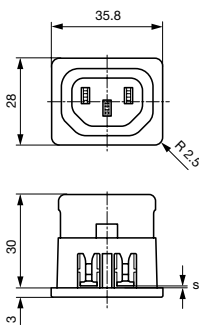

Version "along" (wires along to pin axis)
L/N/PE: IDC terminals

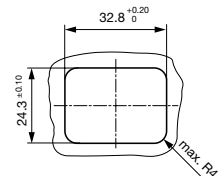
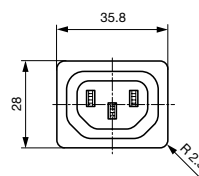

Version "cross" (wires cross to pin axis)
 N/PE: IDC terminals, L: quick connect or solder terminal

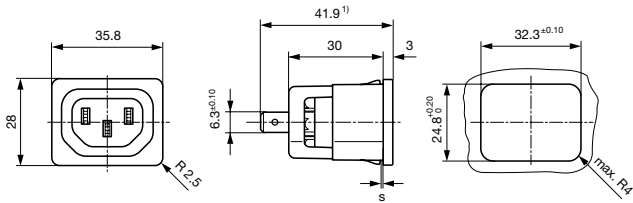

Version "along" (wires along to pin axis)
 N/PE: IDC terminals, L: quick connect or solder terminal

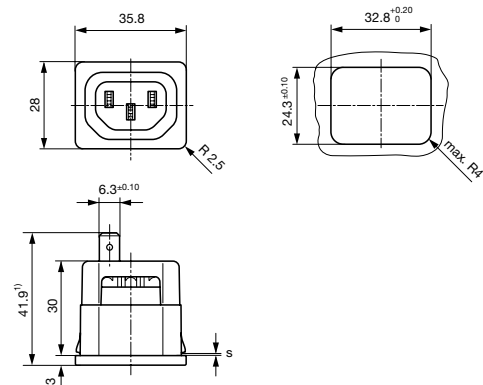

- 1) Other options:
 Quick connect terminal 4.8x0.8: 40.3 mm
 Solder terminal: 40.9 mm

Mounting instructions

Mounting tool version "cross"

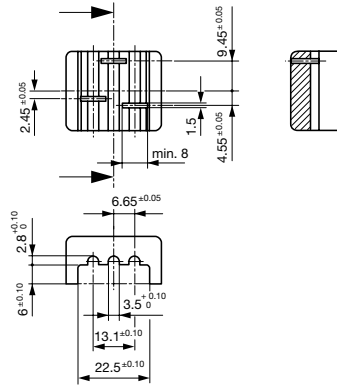

Mounting tool version "along"

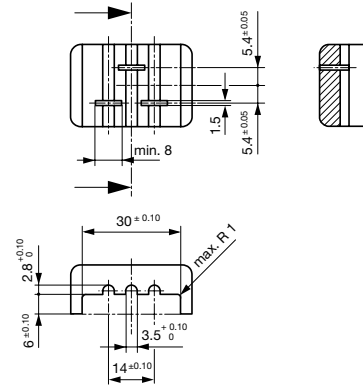

- The above mentioned dimensions are recommended when using an assembly tool.
- When using an assembly tool we recommend the above-mentioned dimensions.
- Use the cover or an assembly tool, to push the wires into the IDC terminals.
- The assembly force depends on the wire used and may require as much as 900 N.
- Press the wires into the IDC terminals until the wires touch with the plastic socket of the 6610 when using a tool.
- When using the cover be sure that it is properly mounted.
- The maximum diameter of the wire (including insulation) is 3.6 mm for along, 3.5 mm for cross version.
- The correct installation of the wires is essential for proper function of the 6610 in the end equipment.

Variants

Alignment ¹⁾	Conductor cross section	Panel Thickness s [mm]	Terminal type live contact	Order Number
along	1.0 - 1.5 mm ²	2.5	IDC terminals	6610.3016.03
along	1.5 mm ² / 14 AWG	1.5	IDC terminals	6610.5014
along	1.5 mm ² / 14 AWG	1.5	IDC terminals	6610.5014.03
along	1.5 mm ² / 14 AWG	2	IDC terminals	6610.5015
along	2.5 mm ² / 12 AWG	0.8	IDC terminals	6610.1011
along	2.5 mm ² / 12 AWG	1	IDC terminals	6610.1012
along	2.5 mm ² / 12 AWG	1.2	IDC terminals	6610.1013
along	2.5 mm ² / 12 AWG	1.5	IDC terminals	6610.1014
along	2.5 mm ² / 12 AWG	2	IDC terminals	6610.1015
along	2.5 mm ² / 12 AWG	2	IDC terminals	6610.1015.03
along	2.5 mm ² / 12 AWG	2.5	IDC terminals	6610.1016
along	2.5 mm ² / 12 AWG	3	IDC terminals	6610.1017

Alignment ¹⁾	Conductor cross section	Panel Thickness s [mm]	Terminal type live contact	Order Number
along	2.5 mm ² / 12 AWG	1.5	Quick connect terminal 6.3 x 0.8	6610.1254
along	2.5 mm ² / 12 AWG	1.5	Quick connect terminal 6.3 x 0.8	6610.1254.03
along	2.5 mm ² / 12 AWG	1.5	Solder	6610.1154
cross	1.5 mm ² / 14 AWG	1	IDC terminals	6610.6012
cross	1.5 mm ² / 14 AWG	1.5	IDC terminals	6610.6014
cross	1.5 mm ² / 14 AWG	1.5	Quick connect terminal 6.3 x 0.8	6610.6254
cross	2.5 mm ² / 12 AWG	1	IDC terminals	6610.2012
cross	2.5 mm ² / 12 AWG	1.2	IDC terminals	6610.2013
cross	2.5 mm ² / 12 AWG	1.5	IDC terminals	6610.2014
cross	2.5 mm ² / 12 AWG	1.5	IDC terminals	6610.2014.03
cross	2.5 mm ² / 12 AWG	2	IDC terminals	6610.2015
cross	2.5 mm ² / 12 AWG	2.5	IDC terminals	6610.2016
cross	2.5 mm ² / 12 AWG	3	IDC terminals	6610.2017
cross	2.5 mm ² / 12 AWG	1.5	Quick connect terminal 6.3 x 0.8	6610.2254
cross	2.5 mm ² / 12 AWG	1.5	Solder	6610.2154

Articles for 1-1.5mm² only with ENEC approval. Outer diameter of wire (including insulation) max. 3.5 / 3.6 mm.

1) The alignment describes whether the wires are along or across to the connector pin axis.

Suffix ".03" corresponds to the version with V-Lock mating cordset. The connector is equipped with a notch intended for use with the latching cordset. The cord latching system prevents against accidental removal of the cordset.

Packaging unit 50 Pcs

Accessories

Description



[Cord retaining kits](#)
Cord retaining strain relief

Mating Inlets/Plugs

Category / Description

[Interconnection Cord Overview complete](#)



Interconnection Cord with IEC Plug E, Angled	0607
Interconnection Cord with IEC Plug E, Angled	0608
Interconnection Cord with IEC Plug E, Straight	0609
Interconnection Cord with IEC Plug G, Angled	607B
Interconnection Cord with IEC Plug G, Angled	608B
Interconnection Cord further types to 6610	...

[Plug Overview complete](#)



IEC Plug E, Cord Connector (Rewireable), Straight, max. cable Diameter 8.5 mm	4732
IEC Plug E, Cord Connector (Rewireable), Angled, max. Cable Diameter 8.5 mm	4733
IEC Plug E, Cord Connector (Rewireable), Straight, max. Cable Diameter 10 mm	4735
IEC Plug E, Cord Connector (Rewireable), Angled, max. Cable Diameter 10 mm	4736
IEC Plug E, Cord Connector (Rewireable), Straight	9009
Plug further types to 6610	...