

SB-53-00

FIS GAS SENSOR SB-53-00

for AMMONIA

The SB-53 is a semiconductor gas sensor which has a high sensitivity to ammonia. This model is suitable for deodorizing apparatus, air purifiers, ventilators, etc.

Structure

Gas sensitive semiconductor material is a mini bead type and a heater coil and electrode wire are embedded in the element. The sensing element is installed in the metal housing which uses double stainless steel mesh (100mesh) in the path of gas flow. The mesh is anti-explosion feature (Fig1b)

Operating conditions

Fig 2 shows the standard operating circuit for this model. The change of the sensor resistance (R_S) is obtained as the change of the output voltage across the fixed or variable resistor (R_L). In order to obtain the best performance and specified characteristics, the values of the heater voltage (V_H) circuit voltage (V_C) and load resistance (R_L) must be within the range of values given in the standard operating conditions shown in the Specification table on the next page.

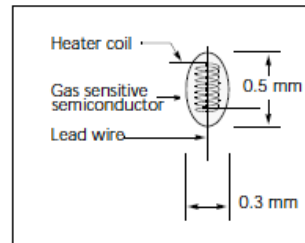

Fig 1a. Sensing element

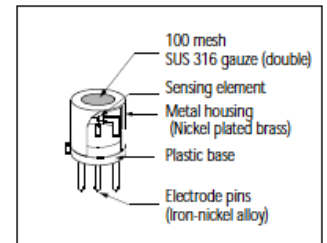

Fig 1b. Configuration

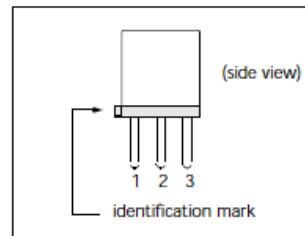

Fig 1c. Pin Layout

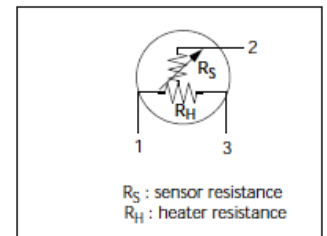

Fig 1d. Equivalent circuit

Sensitivity characteristics

Fig 3 shows the sensitivity characteristics curves of the SB-53 (typical data). Sensitivity characteristics of our gas sensors are expressed by the relationship between the sensor resistance and gas concentration. The sensor resistance decreases with an increase of gas concentration based on a logarithmic function.

The sensitivity characteristics of the SB-53 is specified by the following parameters.

- Sensor resistance level: in clean air
 - Sensor resistance change ratio: between ammonia 10 ppm and in air
- See the specification table on the next page for further details.

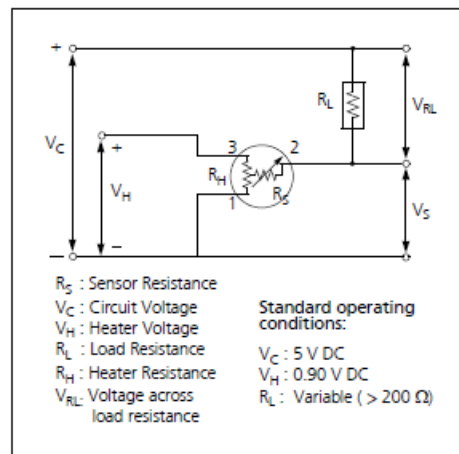

Fig 2. Standard circuit

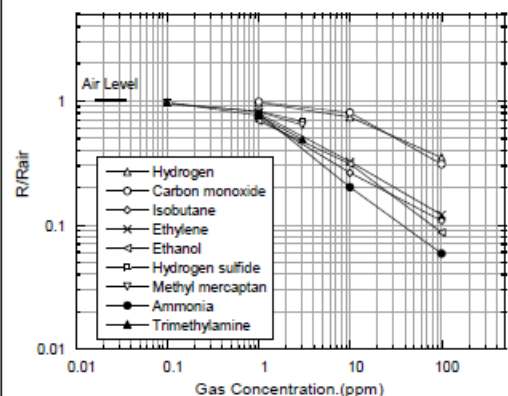

Fig 3. Sensitivity characteristics

SPECIFICATIONS

Specifications: SB-53-00

A. Standard Operating conditions

Symbol	Parameter	Specification	Conditions etc.
VH	Heater voltage	0.9 V ± 0.05 V	AC, DC or pulse
VC	Circuit voltage	Less than 5 V	DC: Pin2 (+) - Pin 1 (-)
RL	Load resistance	Variable (> 200 Ω)	P _S < 10 mW
RH	Heater resistance	2.8 Ω ± 0.2 Ω	at room temperature
IH	Heater current	130 mA (Typical value)	IH = VH / RH
PH	Heater power consumption	120 mW (Typical value)	PH = VH ² / RH
PS	Power dissipation of sensing element	Less than 10mW	$P_S = \frac{(VC-VRL)^2}{R}$

B. Environmental conditions

Symbol	Parameter	Specification	Conditions etc.
T _{ao}	Operating temperature	-10 °C to 50 °C	
T _{as}	Storage temp	-20 °C to 60 °C	
RH	Relative humidity	Less than 95%RH	
(O ₂)	Oxygen concentration	21% ± 1% (Standard condition) The sensitivity characteristics are influenced by the variation in oxygen concentration. Please consult us for details.	Absolute minimum level : more than 18%.

C. Sensitivity characteristics

Model	SB-53-00		
Symbol	Parameter	Specification	Conditions etc.
R _S	Sensor resistance	5 k to 50 kΩ	at clean air
Acetone selectivity		0.10 to 0.50	R _S at 10ppm of Anmonia R _S in air
Standard Test Conditions:		Temp : 20°C±2°C Humidity : 65%±5% (in clean air) Pre-heating time: more than 48 hours	VC : 5.0 V ± 1 % VH : 0.9 V ± 1 % RL : 10 kΩ ± 5%

D. Mechanical characteristics

Items	Conditions	Specifications
Vibration	Frequency: 100 cpm Vertical amplitude: 4 mm Duration: 1 hour	Should satisfy the specifications shown in the sensitivity characteristics after test.
	Shock	

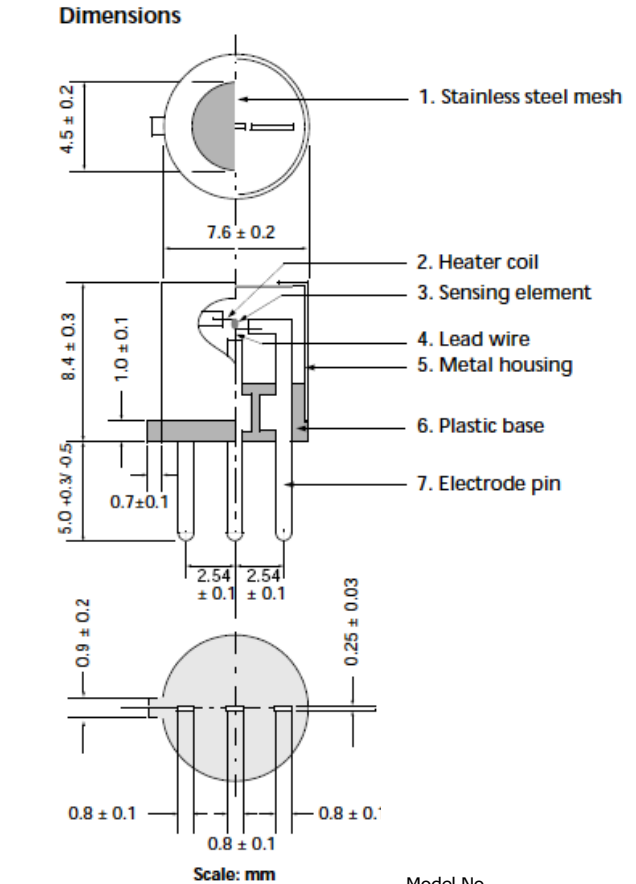

Weight : 0.6g

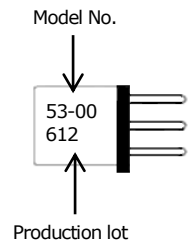

E. Parts and Materials

No.	Parts	Materials
1	Heater coil	Platinum
2	Sensing element	Tungsten oxide (WO ₃)
3	Lead wire	Platinum
4	Metal housing	Nickel plated brass
5	Plastic base	PBT (Poly butylene terephthalate)
6	Electrode pins	Iron-nickel alloy

Please contact

OCTOBER, 2018

Nissha FIS, Inc.
2-4-28, Tagawa
Yodogawa, Osaka
532-0027 Japan

Tel: +81 6-7176-3911
Fax: +81 6-7176-3912
<http://www.fisinc.co.jp>

In the interest of continued product improvement, we reserve the right to change design features without prior notice.