



SPECIFICATIONS SHEET

PRODUCT TYPE : OPEN STRUCTURE ULTRASONIC SENSORS

PRODUCT SERIES : USO16A

DESCRIPTION : USO R 16D 12.2H 10V PIN ALUMINIUM RoHS

COLOR : SILVER

ELECTRICAL SPECIFICATIONS

MODEL NO.	USO16A12RLFPM	
FUNCTION	RECEIVER	
CENTER FREQUENCY	Hz	40000 ± 1000
DIAMETER (A) ± 0.3	mm	Ø 16.0
HEIGHT (B) ± 0.3	mm	12.2
BANDWIDTH (dB)		2.5 K Hz
RECEIVER SENSITIVITY		Min. -60.0 dB (at 40.0 K Hz 0dB = 1 Volt / u bar)
CAPACITANCE AT 1KHz	pF	2100 ± 20 %
MAX. DRIVING VOLTAGE		20.0 V rms
BEAM ANGLE -6 dB		80.0 ° TYPICAL
HOUSING MATERIAL		ALUMINUM
OPERATING TEMPERATURE	°C	-20.0 ~ +70.0
WEIGHT		3.0 g

DIMENSIONS

UNIT : mm

BOTTOM VIEW

SIDE VIEW

TOP VIEW

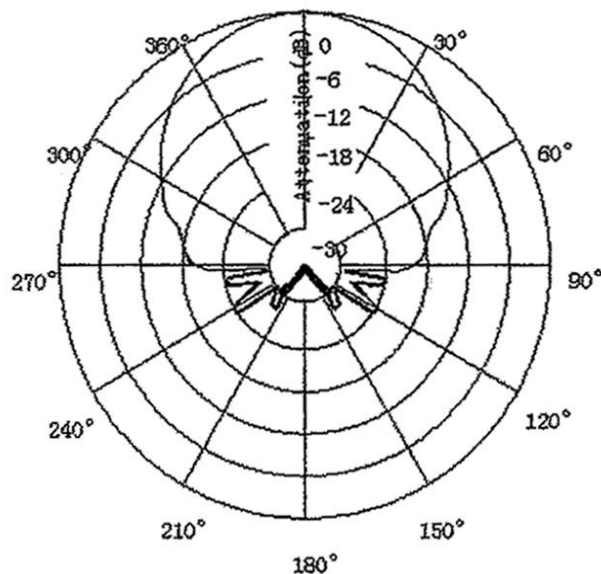
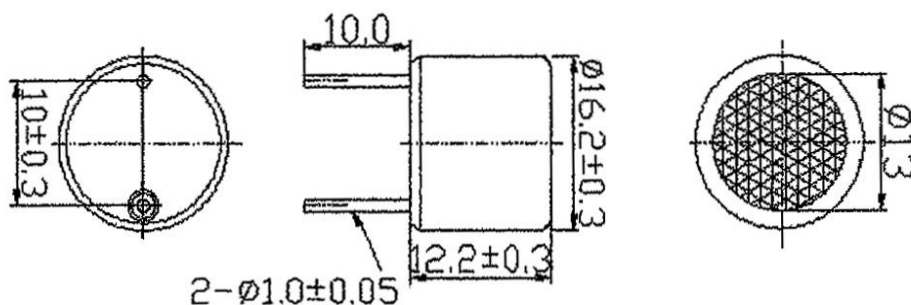

Approved By :
Date : 19-Dec.-2008

Prepared By :
Date : 19-Dec.-2008

Modify :	Date :	By :
Modify Electrical Spec.	19-Dec-08	Joey