

THIS DOCUMENT IS THE PROPERTY OF  
KEYSTONE ELECTRONICS CORP. AND  
SHALL NOT BE REPRODUCED, DISTRIBUTED  
OR USED AS A BASIS FOR MANUFACTURE  
WITHOUT PRIOR WRITTEN PERMISSION  
FROM KEYSTONE ELECTRONICS CORP.

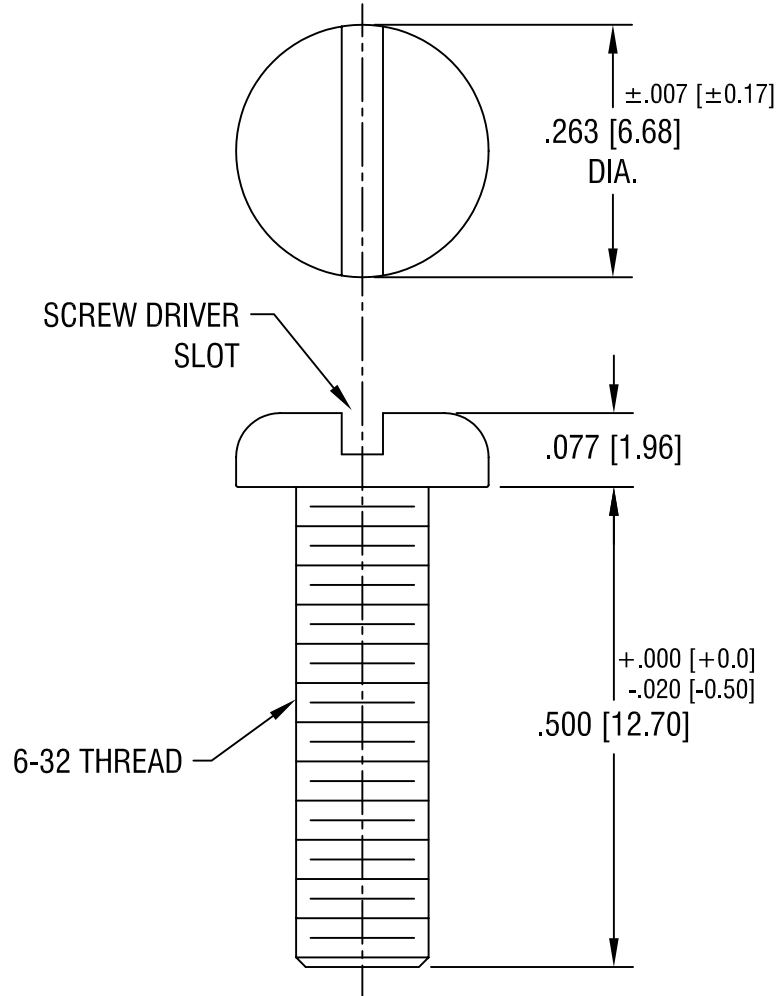

**KEYSTONE ELECTRONICS CORP.**

ASTORIA, N.Y. 11105-2017

PART NAME

PAN HEAD SCREW

MATERIAL

STEEL

FINISH

BRIGHT ZINC

DRN BY

BOONE

DATE

1.30.94

APPD

SCALE

5X

TOLERANCES

INCH [MM]

DECIMAL  $\pm .005$  [ $\pm 0.15$ ]

ANGULAR  $\pm 1^\circ$

UNLESS OTHERWISE SPECIFIED

CODE

C

DWG NO.

4696

DATE

DESCRIPTION

REV.