

REV.	DESCRIPTION	DRAWN	DATE
1	INITIAL RELEASE	FROS	2025/07/28

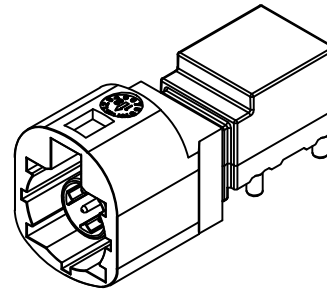
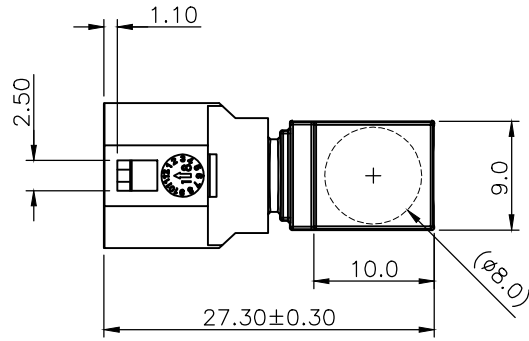

**SPECIFICATION:**

**1. ELECTRICAL**

- 1.1 Impedance: 100Ω
- 1.2 Frequency: DC 2.0 GHz
- 1.3 Return Loss: ≥ 20dB to 1.0 GHz, ≥ 17dB to 2.0 GHz
- 1.4 Insertion Loss: ≤ 0.1 dB at 1.0 GHz
- 1.5 Insulation Resistance: 1000 Min.
- 1.6 Contact Resistance: 10mΩ Max.

**2. MECHANICAL**

- 2.1 Mating Cycles: ≥ 25 cycles
- 2.2 Engagement force: ≤ 30N
- 2.3 Disengagement force: ≥ 5N
- 2.4 Retention force latch: ≥ 110 N
- 2.5 Coding efficiency: ≥ 80N

**3. ENVIRONMENTAL**

- 3.1 Operating temperature range: -40°C~+105°C
- 3.2 Storage temperature range: -40°C~+105°C

**4. SOLDER ABILITY**

- 4.1 Recommended Wave Soldering Temperature: 260°C

**How to order**

231A- P 0 Z 00

Z: Z Code  
 0: Right angle 12 o'clock  
 6: Right angle 6 o'clock

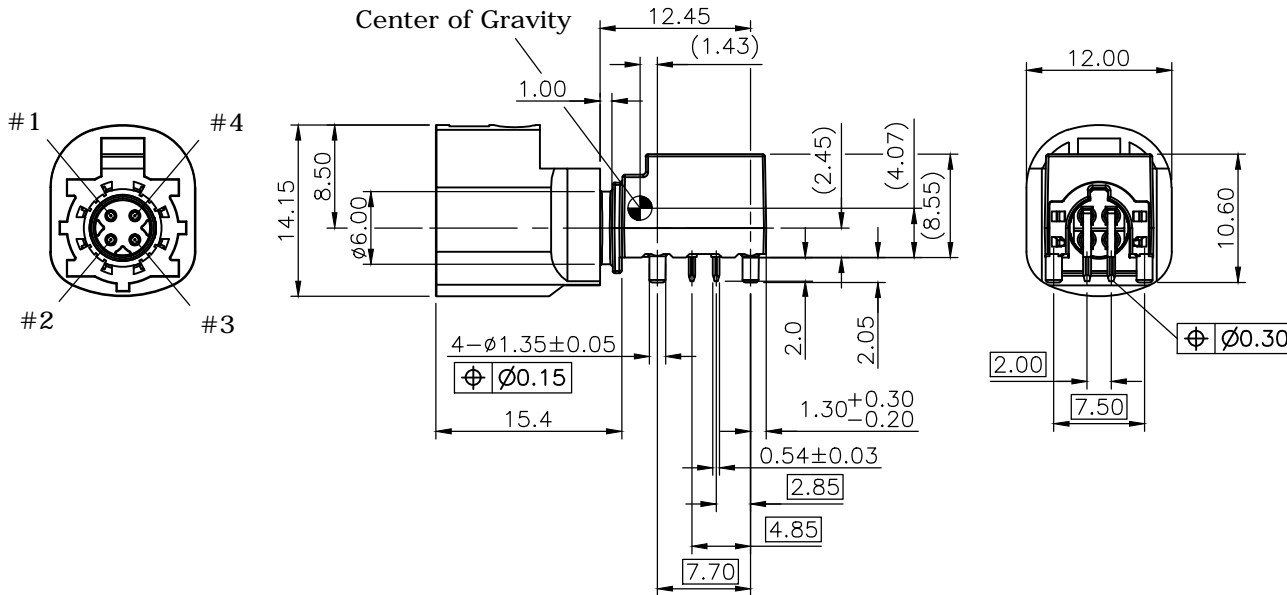

3	SHELL	Zinc alloy, matte tin over nicekl plating
2	CONTACT	Brass, 6u" Gold plating on contact area, matte tin on solder area, under plating nickel over all
1	HOUSING	PA9T, UL94V-0



NO.	PART NAME	DESCRIPTION		
UNLESS OTHERWISE SPECIFIED TOLERANCE				
UNIT:	DECIMAL	LINEAR	ANGLES	
	mm	X. ±0.50	±5°	
		X.X ±0.25	±3°	
		X.XX ±0.12	±1°	
www.attend.com.tw				
DRAWN	Fros	2025/07/28	DRAWN NAME: HSD Plug, Right Angle Type	
CHECKED	Tim	2025/07/28		
APPROVED	Ken	2025/07/28		
SCALE 1.6/1		SHEET 1/4	SIZE A4	PRODUCT NO. 231A-PXX00
FILE NAME 231A-PXX00_B_1				

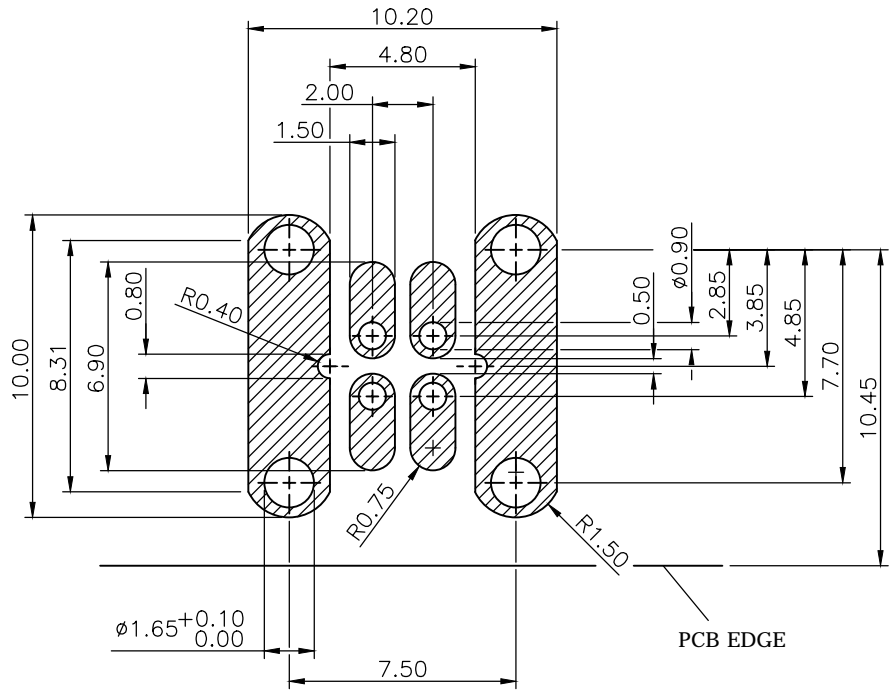



**Recommended Layout (top view)**  
**General Tolerance:  $\pm 0.05\text{mm}$**

REV.	DESCRIPTION	DRAWN	DATE
------	-------------	-------	------

UNLESS OTHERWISE SPECIFIED TOLERANCE				 www.attend.com.tw	
UNIT:	DECIMAL	LINEAR	ANGLES		
mm	X.	$\pm 0.50$	$\pm 5^\circ$		
	X.X	$\pm 0.25$	$\pm 3^\circ$		
	X.XX	$\pm 0.12$	$\pm 1^\circ$		
DRAWN	Fros	2025/07/28	DRAWN NAME:		
CHECKED	Tim	2025/07/28	HSD Plug, Right Angle Type		
APPROVED	Ken	2025/07/28	PRODUCT NO.	231A-PXX00	
	SCALE	SHEET	SIZE	FILE NAME	
	4/1	2/4	A4	231A-PXX00_B_1	

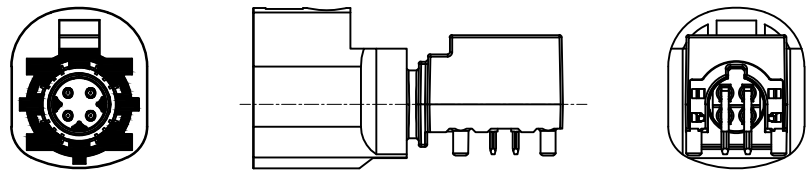
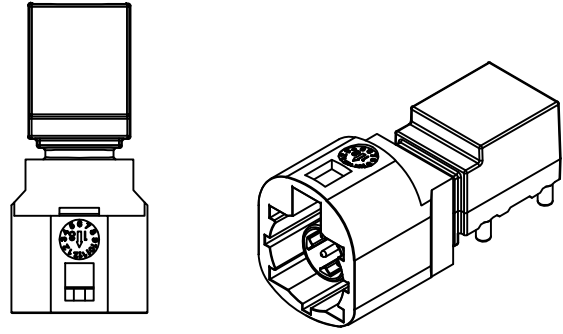

REV.	DESCRIPTION	DRAWN	DATE



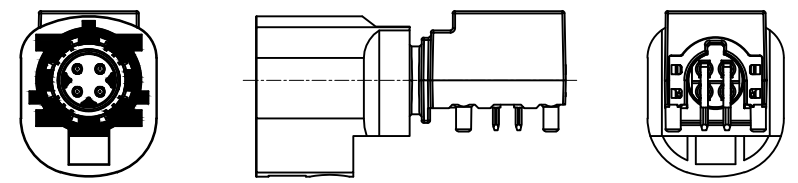
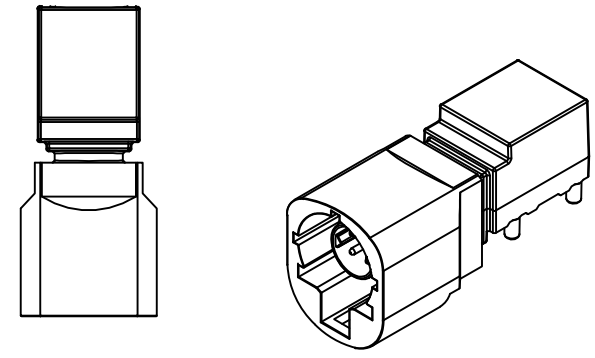







0: Right angle 12 o'clock  
for A/B/C/D/E/F/Z Code



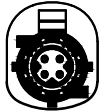
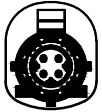

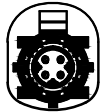
6: Right angle 6 o'clock  
for A/B/C/D Code

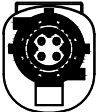
UNLESS OTHERWISE SPECIFIED TOLERANCE				 www.attend.com.tw	
UNIT:	DECIMAL	LINEAR	ANGLES		
mm	X.	±0.50	±5°		
	X.X	±0.25	±3°		
	X.XX	±0.12	±1°		
DRAWN	Fros	2025/07/28	DRAWN NAME:		
CHECKED	Tim	2025/07/28	HSD Plug, Right Angle Type		
APPROVED	Ken	2025/07/28	PRODUCT NO.	231A-PXX00	
	SCALE 1.6/1	SHEET 3/4	SIZE A4	FILE NAME	231A-PXX00_B_1

REV.	DESCRIPTION	DRAWN	DATE
------	-------------	-------	------

CODINGS 1 : 1							
Coding	A	B	C	D	E	F	Z
Plug							
Color	Black	White	Blue	Bordeaux	Green	Brown	Water Blue
RAL	sim.9005	sim.9001	sim.5005	sim.4004	sim.6002	sim.8011	sim.5021
Coding	A	B	C	D			
Plug							
Color	Black	White	Blue	Bordeaux			
RAL	sim.9005	sim.9001	sim.5005	sim.4004			

UNLESS OTHERWISE SPECIFIED TOLERANCE				 www.attend.com.tw	
UNIT:	DECIMAL	LINEAR	ANGLES		
mm	X.	±0.50	±5°		
	X.X	±0.25	±3°		
	X.XX	±0.12	±1°		
DRAWN	Fros	2025/07/28	DRAWN NAME:		
CHECKED	Tim	2025/07/28	HSD Plug, Right Angle Type		
APPROVED	Ken	2025/07/28	PRODUCT NO.	231A-PXX00	
	SCALE 1/1	SHEET 4/4	SIZE A4	FILE NAME	231A-PXX00_B_1

REV.	DESCRIPTION	DRAWN	DATE
1	INITIAL RELEASE	FROS	2025/07/28

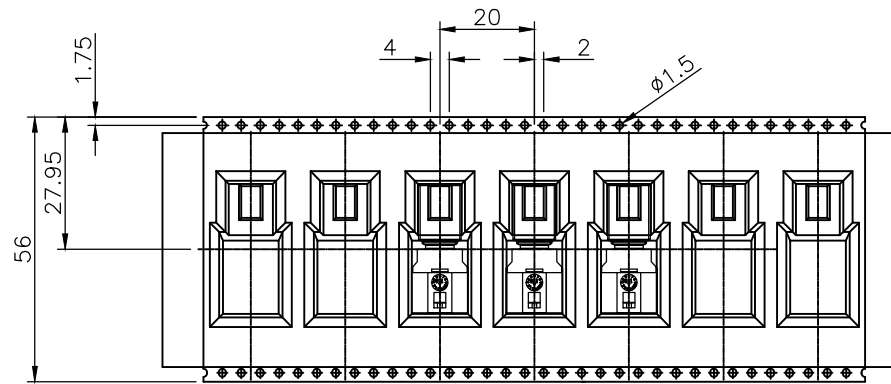
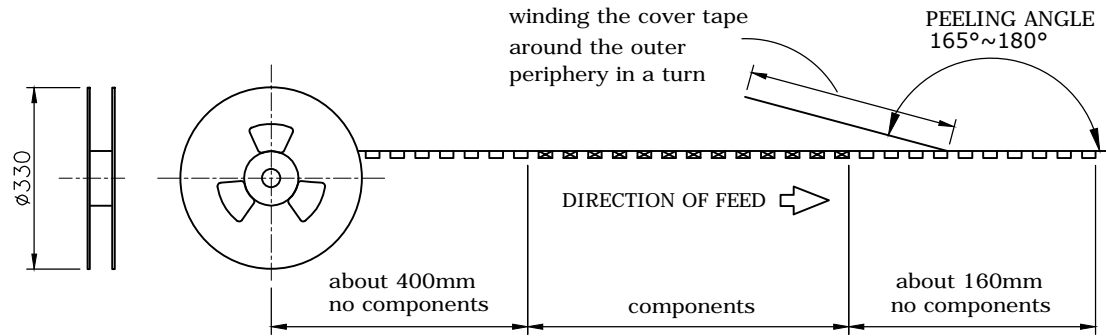

## PACKAGING SPECIFICATION:

### 1. MATERIAL

- 1.1 Embossed Carrier Tape: PS Black
- 1.2 Top Cover Tape: PET  
20-80g (Peel Speed 300mm/Minute)
- 1.3 Taping Reel: Plastic

### 2. PACKING

- 2.1 Quantity:  
200 Piece/Reel  
5 Reel/Carton  
1000 Piece/Carton

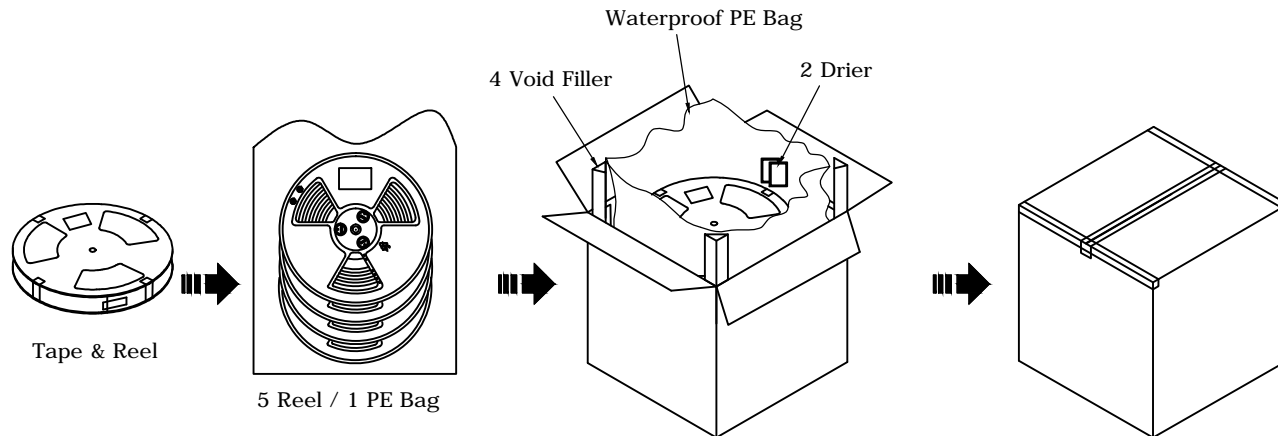

Carton L\*W\*H= 355\*355\*340

UNLESS OTHERWISE SPECIFIED TOLERANCE

UNIT:	DECIMAL	LINEAR	ANGLES
mm	X.	±0.50	±5°
	X.X	±0.25	±3°
	X.XX	±0.12	±1°



www.attend.com.tw

DRAWN	Fros	2025/07/28	DRAWN NAME:
CHECKED	Tim	2025/07/28	HSD Plug, Right Angle Type
APPROVED	Ken	2025/07/28	PRODUCT NO. 231A-PXX00
SCALE	0.625	SHEET 1/1	SIZE A4
FILE NAME			231A-PXX00_D_1



SCALE  
0.625

SHEET  
1/1

SIZE  
A4

FILE NAME

231A-PXX00\_D\_1