

PCB Relay G6RL

Low-profile power relay with maximum switching of 10 A

- Low profile: 12.3 mm in height
- Max. switching capacity: 2,500 VA (NO)
- IEC 60947-5-1, AC-15, DC13
- Clearance and creepage distance: 10 mm.
- Models with high shock resistance (250 m/s²) are available.
- Models for P1 load (2 × 200 W lamps parallel to ignition transformer) are available.
- RoHS Compliant

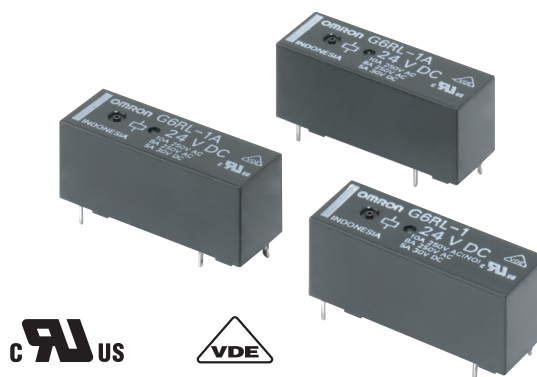

Applications:

Boilers, PLCs, I/O ports, timers, and temperature controllers

Ordering Information

Classification	Enclosure rating	Contact form	Contact material	
			AgSnIn	AgNi
Standard	Flux protection	SPST-NO	G6RL-1A-ASI	G6RL-1A
		SPDT	G6RL-1-ASI	G6RL-1
	Fully sealed	SPST-NO	G6RL-1A4-ASI	---
		SPDT	G6RL-14-ASI	---
P1 Load	Flux protection	SPST-NO	G6RL-1A-ASI-PL	---
		SPDT	G6RL-1-ASI-PL	---
Shock resistance	Flux protection	SPST-NO	---	---
		SPDT	G6RL-1-SR-ASI	---
	Fully sealed	SPST-NO	---	---
		SPDT	G6RL-14-SR-ASI	---

Note: When ordering, add the rated coil voltage to the model number.

Examples: G6RL-1A DC12
└─ Rated coil voltage

Model Number Legend:

G6RL- - - - DC
1 2 3 4 5 6 7

1. Number of Poles

1: 1 pole

2. Contact Form/Contact Construction

None: SPDT

A: SPST-NO

3. Enclosure Rating

None: Flux protection

4: Fully sealed

4. Special Function 1

SR: Shock resistance of 25G

5. Contact material

None: AgNi

ASI: AgSnIn

6. Special Function 2

PL: P1 load (See note.)

7. Rated Coil Voltage

3, 5, 6, 12, 24, or 48

Note: Please refer to *Endurance Under Real Load* table in this datasheet.

Specifications

■ Coil Ratings

Classification	Standard, P1 load						Shock resistance				
	3 VDC	5 VDC	6 VDC	12 VDC	24 VDC	48 VDC	3 VDC	5 VDC	6 VDC	12 VDC	24 VDC
Rated voltage	3 VDC	5 VDC	6 VDC	12 VDC	24 VDC	48 VDC	3 VDC	5 VDC	6 VDC	12 VDC	24 VDC
Rated current	73.3 mA	44 mA	36.7 mA	18.3 mA	9.2 mA	5 mA	101 mA	60.2 mA	50.1 mA	25.2 mA	12.6 mA
Coil resistance	40 Ω	113 Ω	163 Ω	654 Ω	2,618 Ω	9,600 Ω	30 Ω	83 Ω	120 Ω	476 Ω	1,912 Ω
Must operate voltage	70% max. of rated voltage						80% max. of rated voltage				
Must release voltage	10% min. of rated voltage						10% min. of rated voltage				
Max. voltage	150% of rated voltage						150% of rated voltage (23°C)				
Power consumption	Approx. 220 mW					Approx. 240 mW	Approx. 300 mW				

Note: 1. The above items are measured at a coil temperature of 23°C.
 2. The tolerance of the rated current is ±10%.

■ Contact Ratings

Load	Resistive load (cos φ = 1)
Rated load (See note 1.)	10 A at 250 VAC, NO resistive load 8 A at 250 VAC, resistive load 5 A at 30 VDC, resistive load
Rated carry current	10 A at 250 VAC 5 A at 30 VDC
Max. switching voltage	400 VAC, 300 VDC
Max. switching current	NO: 10 A, NC: 8 A
Max. switching power	NO: 2,500 VA, NC: 2,000 VA 150 W
Failure rate (reference value)	10 mA at 5 VDC (P level) (See note 2.)

Note: 1. G6RL-1(A), G6RL-1(A)4-ASI: 8 A 250 VAC, resistive load; 5 A 24 VDC resistive load.
 2. P level: $\lambda_{60} = 0.1 \times 10^{-6}$ / operations

■ Characteristics

Contact resistance	100 mΩ max.
Operate time	10 ms max. (SR Models: 15 ms max.)
Release time	5 ms max.
Insulation resistance	1,000 MΩ min. (at 500 VDC)
Dielectric strength	5,000 VAC, 50/60 Hz for 1 min between coil and contacts 1,000 VAC, 50/60 Hz for 1 min between contacts of same polarity
Impulse withstand voltage	10 kV between coil and contacts (1.2 × 50 μs)
Vibration resistance	Destruction: 10 to 55 to 10 Hz, 1.5-mm double amplitude Malfunction: 10 to 55 to 10 Hz, 0.825-mm single amplitude (1.65-mm double amplitude) when energized. 10 to 55 to 10 Hz, 0.4-mm single amplitude (0.8-mm double amplitude) when not energized.
Shock resistance	Destruction: 1,000 m/s ² Malfunction: NO: 200 m/s ² , NC: 50 m/s ² when not energized SR Models: 250 m/s ² (NO and NC) when not energized
Endurance	Mechanical: 10,000,000 operations min. (at 18,000 operations/hr)
Ambient temperature	Operating: -40°C to 85°C (with no icing)
Ambient humidity	Operating: 5% to 85%
Weight	Approx. 7.8 g

■ Other Data

Construction of protection	Flux protection	Fully sealed
Insulation material group	IIIa	
Rated insulation voltage	250 V	
Pollution degree	3	2
Rated voltage system	250 V	400 V
Overtoltage category	III	
Creepage distance	10 mm	
Clearance distance	10 mm	
RoHS	Compliant	
Tracking index of relay base	PTI 250	
Flammability class according to UL94	V-0	
Flammability-flame GWFI (IEC 60695-2-12) GWIT (IEC 60695-2-13)	850°C 750°C	
Ball pressure test (IEC 60695-10-2)	170°C	

■ Approved Standards

UL Recognized (File No. E41643) - - Ambient Temp. = 85°C

Models	Contact form	Coil rating	Contact rating	
G6RL-1A	SPST-NO	3 to 48 VDC	10 A at 250 VAC (NO) (Resistive) 8 A at 250 VAC (Resistive) 5 A at 30 VDC (Resistive)	6,000 operations
G6RL-1	SPDT			
G6RL-1A(4)-ASI	SPST-NO			
G6RL-1(4)-ASI	SPDT			
G6RL-1(4)-SR-ASI	SPDT	3 to 24 VDC		

VDE (EN61810-1) (Certificate No.C266)

Models	Contact form	Coil rating	Contact rating	Model
G6RL-1A-(ASI)	SPST-NO	3, 5, 6, 12, 24, or 48 VDC	10 A at 250 VAC (NO)	10,000 operations at 85°C
G6RL-1-(ASI)	SPDT		8 A at 250 VAC	30,000 operations at 85°C
			5 A at 30 VDC	50,000 operations at 85°C
G6RL-1A4-ASI (See note.)	SPST-NO	3, 5, 6, 12, 24, or 48 VDC	10 A at 250 VAC (NO)	10,000 operations at 85°C
G6RL-14-ASI (See note.)	SPDT		8 A at 250 VAC	10,000 operations at 85°C
			5 A at 30 VDC	10,000 operations at 85°C
G6RL-1(4)-SR-ASI	SPDT	3, 5, 6, 12 or 24 VDC	10 A at 250 VAC (NO)	10,000 operations at 85°C
			8 A at 250 VAC	10,000 operations at 85°C
			5 A at 30 VDC	10,000 operations at 85°C

Note: In progress

VDE (60947-5-1) (Certificate No. C266)

Models	Contact rating			
	Utilization category		Rated voltage (V)	Operations
G6RL-1(A)	AC15 (NO)	le: 3 A, lthe: 10 A (A300)	AC240	6,000
	AC15 (NO)	le: 3 A, lthe: 5 A (B300)	AC120	6,000
	AC15 (NO)	le: 1.5 A, lthe: 5 A (B300)	AC240	6,000
	DC13	le: 0.22A, lthe: 1A (R150)	DC125	6,000
	DC13 (See note.)	le: 0.1 A, lthe: 1 A (R300)	DC250	6,000
G6RL-1(A)-ASI G6RL-1(A)4-ASI (See note.) G6RL-1(4)-SR-ASI	AC15	le: 3 A, lthe: 10 A (A300)	AC240	6,000
	AC15	le: 3 A, lthe: 5 A (B300)	AC120	6,000
	AC15	le: 1.5 A, lthe: 5 A (B300)	AC240	6,000
	DC13	le: 0.22 A, lthe: 1 A (R150)	DC125	6,000
	DC13 (See note.)	le: 0.1 A, lthe: 1 A (R300)	DC250	6,000

Note: 1. In progress
2. All ratings are valid at Room Temperature

VDE (60947-4-1) (Certificate No. C266)

Models	Contact rating			
	Utilization category		Rated voltage (V)	Operations
G6RL-1(A) G6RL-1(A)-ASI (See note.)	AC1	8 A	AC250	6,000
	AC3	2 A	AC250	6,000
	DC1	5 A	DC24	6,000
	DC3	2 A	DC24	6,000

Note: 1. In progress
2. All ratings are valid at Room Temperature

VDE (EN60730-1) (Certificate No. C266)

Models	Contact rating			
	Utilization category		Rated voltage (V)	Operations
G6RL-1(A)	2 (2) A	65°C	AC250	100,000
	8 (4) A (NO)	85°C	AC250	100,000
	6 (4) A (NO)	85°C (See note.)	AC250	100,000
	6 (4)A (NO)	65°C	AC250	100,000
	6 (4) A (NC)	65°C	AC250	100,000
G6RL-1(A)-ASI (See note.)	2 (2) A	65°C	AC250	100,000
	8 (4) A (NO)	85°C	AC250	100,000
	6 (4) A (NO)	85°C	AC250	100,000
	6 (4) A (NC)	65°C	AC250	100,000

Note: In progress

Electrical Endurance Data

G6RL-1(A)	8 A at 250 VAC ($\cos\phi = 1$) NO	50,000 operations min.
	8 A at 250 VAC ($\cos\phi = 1$) NC	50,000 operations min.
	5 A at 24 VDC	50,000 operations min.
G6RL-1(A)-(SR)-ASI-(PL)	10 A at 250 VAC ($\cos\phi = 1$) NO	100,000 operations min.
	8 A at 250 VAC ($\cos\phi = 1$)	100,000 operations min.
	5 A at 30 VDC	50,000 operations min.
G6RL-1(A)4-ASI	8 A at 250 VAC ($\cos\phi = 1$) NO	50,000 operations min.
	8 A at 250 VAC ($\cos\phi = 1$) NC	50,000 operations min.
	5 A at 24 VDC	50,000 operations min.
G6RL-14-SR-ASI	8 A at 250 VAC ($\cos\phi = 1$) NO	50,000 operations min.
	3 A at 250 VAC ($\cos\phi = 1$) NC	100,000 operations min.
	5 A at 24 VDC NO	50,000 operations min.
	5 A at 24 VDC NC	30,000 operations min.

Endurance Under Real Load (Reference Only)

G6RL-1(A)-ASI-PL

Rated voltage	Condition	Frequency	Electrical life
230 VAC	P1 load (2 × 200 W lamps parallel to ignition transformer)	1.5 s ON/4.5 s OFF	250,000 operations

Note: The results shown reflect values measured using very severe test conditions, i.e., Duty: 1 s ON/OFF.
 Electrical endurance will vary depending on the test conditions. Contact your OMRON representative if you require more detailed information for the electrical endurance under your test conditions.

Engineering Data

G6RL-1(A)(4)-(SR)-(ASI)-(PL) Maximum Switching Capacity

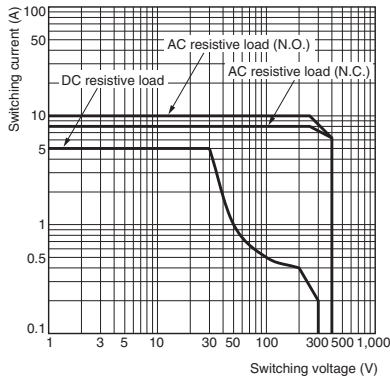

G6RL-1(A) Endurance

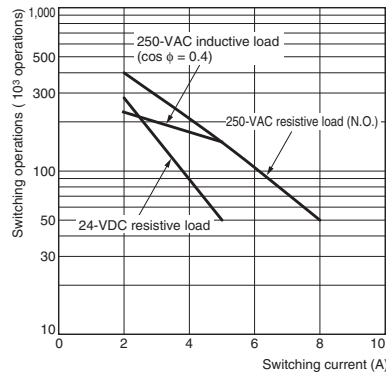

G6RL-1(A)(4)-(SR)-(ASI)-(PL) Ambient Temperature vs. Maximum Coil Voltage

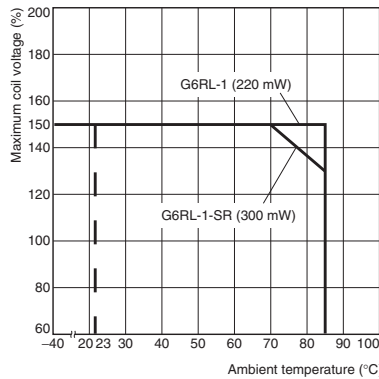

G6RL-1(A)(4)-(ASI)-(PL) Ambient Temperature vs. Must Operate or Must Release Voltage

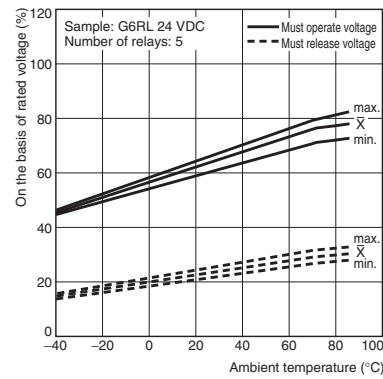

Note: The "maximum coil voltage" refers to the maximum value in a varying range of operating voltage, not a continuous voltage.

Dimensions

Note: All units are in millimeters unless otherwise indicated.

G6RL-1A(-ASI) G6RL-1A4(-ASI)

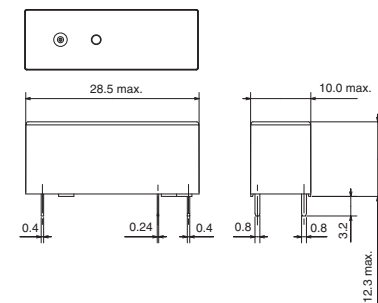
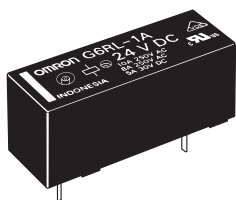

Terminal Arrangement/ Internal Connections (Bottom View)



Mounting Holes (Bottom View)

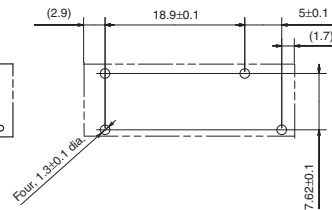

Note: Indicates average dimensions.

G6RL-1(-ASI) G6RL-14(-ASI)

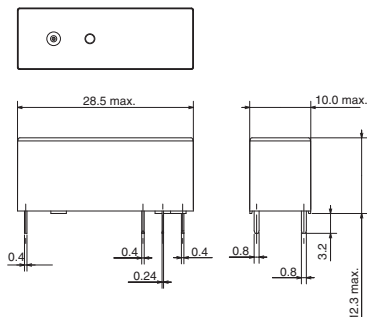
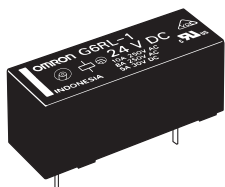

Terminal Arrangement/ Internal Connections (Bottom View)



Mounting Holes (Bottom View)

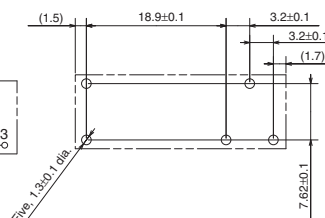

Note: Indicates average dimensions.



All sales are subject to Omron Electronic Components LLC standard terms and conditions of sale, which can be found at http://www.components.omron.com/components/web/webfiles.nsf/sales_terms.html

ALL DIMENSIONS SHOWN ARE IN MILLIMETERS.
To convert millimeters into inches, multiply by 0.03937. To convert grams into ounces, multiply by 0.03527.

OMRON[®]

**OMRON ELECTRONIC
COMPONENTS LLC**

55 E. Commerce Drive, Suite B
Schaumburg, IL 60173

847-882-2288

OMRON ON-LINE

Global - <http://www.omron.com>

USA - <http://www.components.omron.com>

Cat. No. X301-E-1b

09/11

Specifications subject to change without notice

Printed in USA