

**ebm-papst Mulfingen GmbH & Co. KG**

Bachmühle 2 · D-74673 Mulfingen

Phone +49 7938 81-0

Fax +49 7938 81-110

info1@de.ebmpapst.com

www.ebmpapst.com

Limited partnership · Headquarters Mulfingen

Amtsgericht (court of registration) Stuttgart · HRA 590344

General partner Elektrobau Mulfingen GmbH · Headquarters Mulfingen

Amtsgericht (court of registration) Stuttgart · HRB 590142

**Nominal data**

<b>Type</b>	<b>R2D160-AF02-01</b>		
<b>Motor</b>	<b>M2D068-EC</b>		
Phase		3~	3~
Nominal voltage	VAC	230	400
Wiring		Δ	Y
Frequency	Hz	50	50
Method of obtaining data		fa	fa
Valid for approval/standard		CE	CE
Speed (rpm)	min <sup>-1</sup>	2250	2250
Power consumption	W	305	305
Current draw	A	0.82	0.48
Min. back pressure	Pa	0	0
Min. back pressure	inH <sub>2</sub> O	0	0
Min. ambient temperature	°C	-25	-25
Max. ambient temperature	°C	50	50
Starting current	A	1.75	1.0

ml = Max. load · me = Max. efficiency · fa = Free air · cs = Customer specification · ce = Customer equipment  
Subject to change

**Data according to ErP Directive**

		Actual	Req. 2015
01 Overall efficiency $\eta_{es}$	%	34	32.5
02 Measurement category		A	
03 Efficiency category		Static	
04 Efficiency grade N		45.5	44
05 Variable speed drive		No	

Data obtained at optimum efficiency level.  
The ErP data is determined using a motor-impeller combination in a standardized measurement setup.

09 Power consumption $P_e$	kW	0.15
09 Air flow $q_v$	m <sup>3</sup> /h	390
09 Pressure increase $p_{fs}$	Pa	501
10 Speed (rpm) n	min <sup>-1</sup>	2685
11 Specific ratio*		1.01

\* Specific ratio =  $1 + p_{fs} / 100\,000\text{ Pa}$

LU-39223



### Technical description

<b>Weight</b>	2.5 kg
<b>Fan size</b>	160 mm
<b>Impeller material</b>	Sheet steel, galvanized
<b>Direction of rotation</b>	Clockwise, viewed toward rotor
<b>Degree of protection</b>	IP44; installation- and position-dependent
<b>Insulation class</b>	"B"
<b>Moisture (F) / Environmental (H) protection class</b>	F1-1
<b>Max. permitted ambient temp. for motor (transport/storage)</b>	+ 80 °C
<b>Min. permitted ambient temp. for motor (transport/storage)</b>	- 40 °C
<b>Installation position</b>	Any
<b>Condensation drainage holes</b>	None
<b>Mode</b>	S1
<b>Motor bearing</b>	Ball bearing
<b>Touch current according to IEC 60990 (measuring circuit Fig. 4, TN system)</b>	< 0.75 mA
<b>With cable</b>	Lateral
<b>Protection class</b>	I (with customer connection of protective earth)
<b>Conformity with standards</b>	EN 60335-1, motor does not have factory-installed overheating protection; CE
<b>Approval</b>	CCC

Product drawing

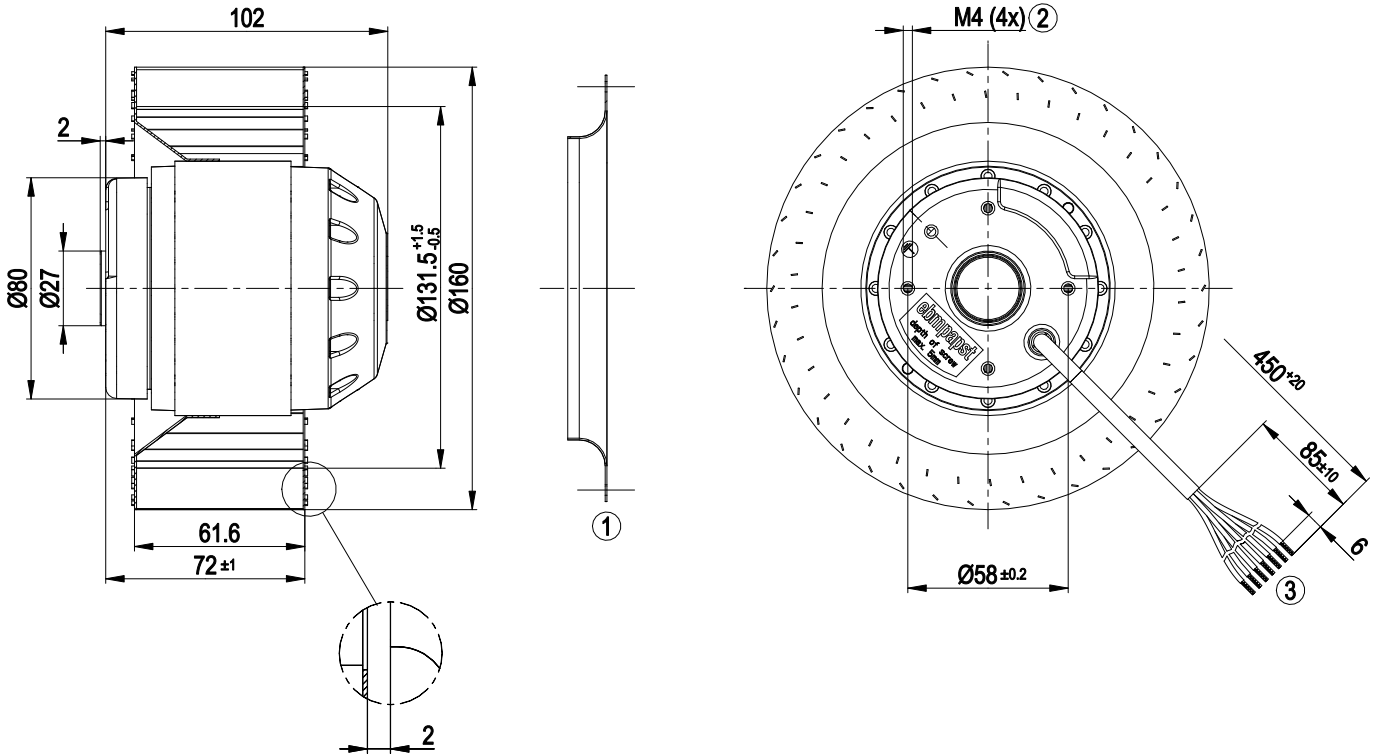

1	Accessory part: inlet ring 09588-2-4013 not included in scope of delivery
2	Max. clearance for screw 5 mm
3	Cable PVC, 7G, 7 x crimped splices

## Accessory part

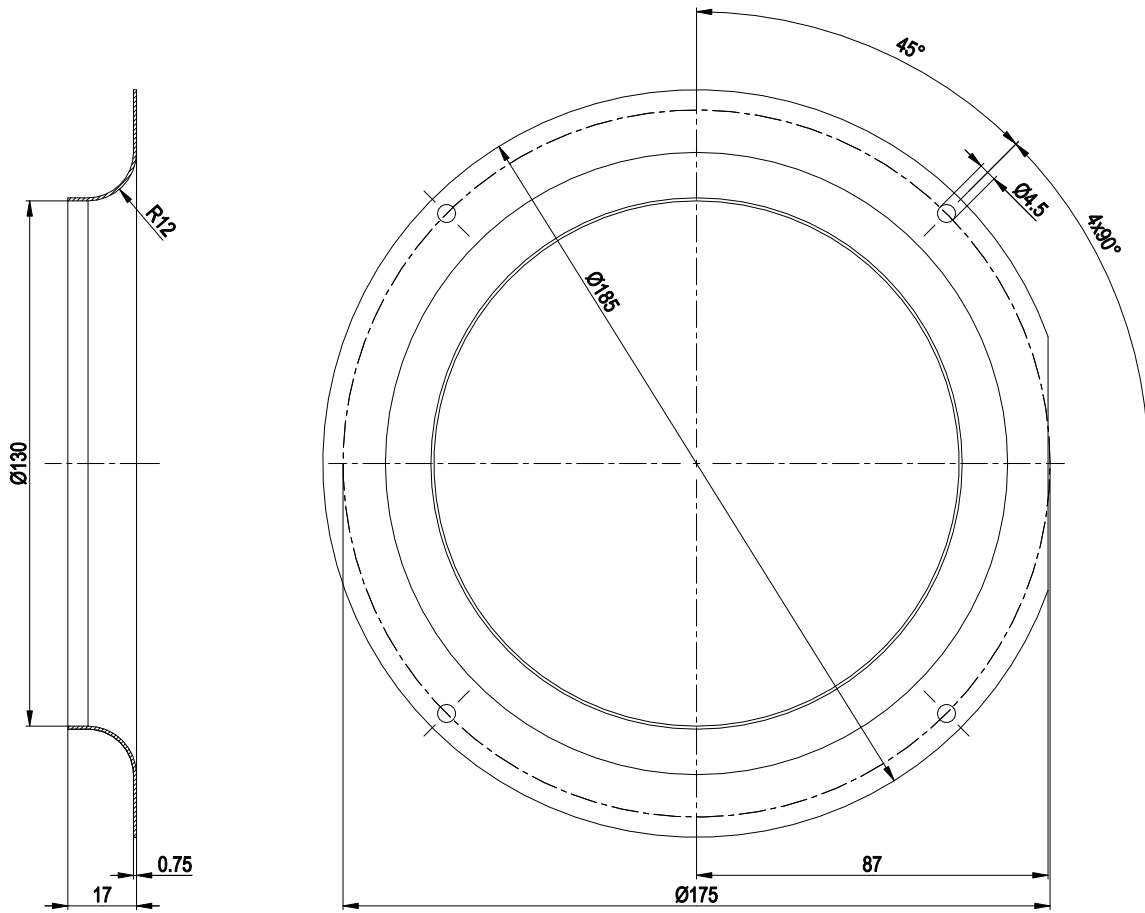

Accessory part: inlet ring 09588-2-4013 not included in scope of delivery

## Connection diagram

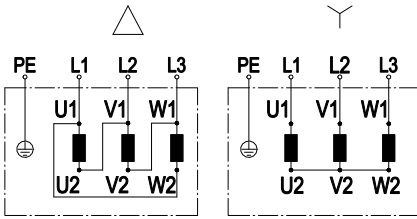

Change of rotation direction by reversing two phases

	Three-phase motor	Δ	Delta connection	Y	Star connection
L1	= U1 = black	L2	= V1 = blue	L3	= W1 = brown
U2	green	V2	white	W2	yellow
PE	green/yellow				

## Curves: Air performance 50 Hz

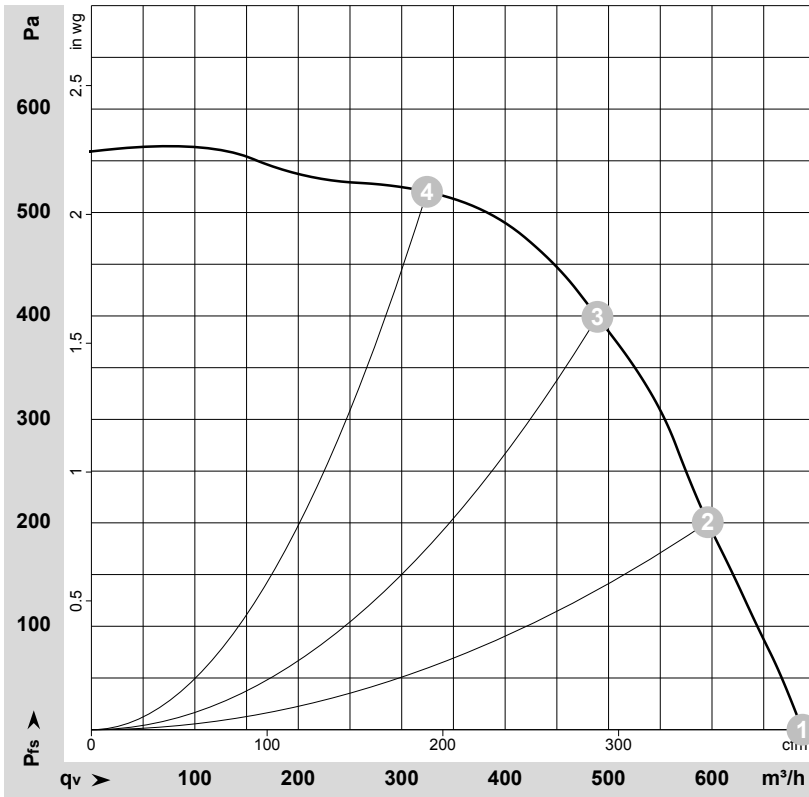

$\rho = 1.15 \text{ kg/m}^3 \pm 2 \%$

Measurement: LU-39223-1

Air performance measured according to ISO 5801 installation category A. For detailed information on the measurement setup, contact ebmpapst. Intake sound level: Sound power level according to ISO 13347 / sound pressure level measured at 1 m distance from fan axis. The values given are valid under the specified measuring conditions and may vary due to conditions of installation. For deviations from the standard configuration, the parameters have to be checked on the installed unit.

## Measured values

	Wired	U	f	n	P <sub>e</sub>	I	qv	p <sub>fs</sub>	qv	p <sub>fs</sub>
		V	Hz	min <sup>-1</sup>	W	A	m <sup>3</sup> /h	Pa	CFM	inH <sub>2</sub> O
1	Y	400	50	2250	305	0.48	685	0	405	0.00
2	Y	400	50	2440	253	0.40	595	200	350	0.80
3	Y	400	50	2585	199	0.33	490	400	290	1.61
4	Y	400	50	2735	138	0.25	325	520	190	2.09

Wired = Wiring · U = Power supply · f = Frequency · n = Speed (rpm) · P<sub>e</sub> = Power consumption · I = Current draw · qv = Air flow · p<sub>fs</sub> = Pressure increase

