

# **FriendlyARM**

**Mini2440**

[www.FriendlyARM.net](http://www.FriendlyARM.net)

1 Introduction.....	3
1.1 Features.....	4
2 Hardware Resource.....	6
2.1 Jumpers and Interfaces.....	6
2.2 Memory Map.....	7
2.2.1 Memory Adress Allocation.....	7
2.3 Power Supply.....	8
2.4 System Reset.....	8
2.5 SDRAM.....	8
2.6 Flash.....	8
2.7 User LEDs.....	8
2.8 User Buttons.....	9
2.9 ADC.....	9
2.10 PWM Buzzer.....	10
2.11 EEPROM.....	10
2.12 JTAG.....	10
2.13 Ethernet.....	10
2.14 UART.....	11
2.15 USB.....	11
2.16 LCD Interface.....	11
2.17 Camera Interface.....	12
2.18 Audio In- and Output.....	12
2.19 System Bus.....	12
2.20 GPIO.....	12

# 1 Introduction

The FriendlyARM Mini2440 is a single board computer based on a Samsung S3C2440 ARM9 microprocessor. The board measures 10 cm x 10 cm, ideal for learning about ARM systems or integrating into numerous products.

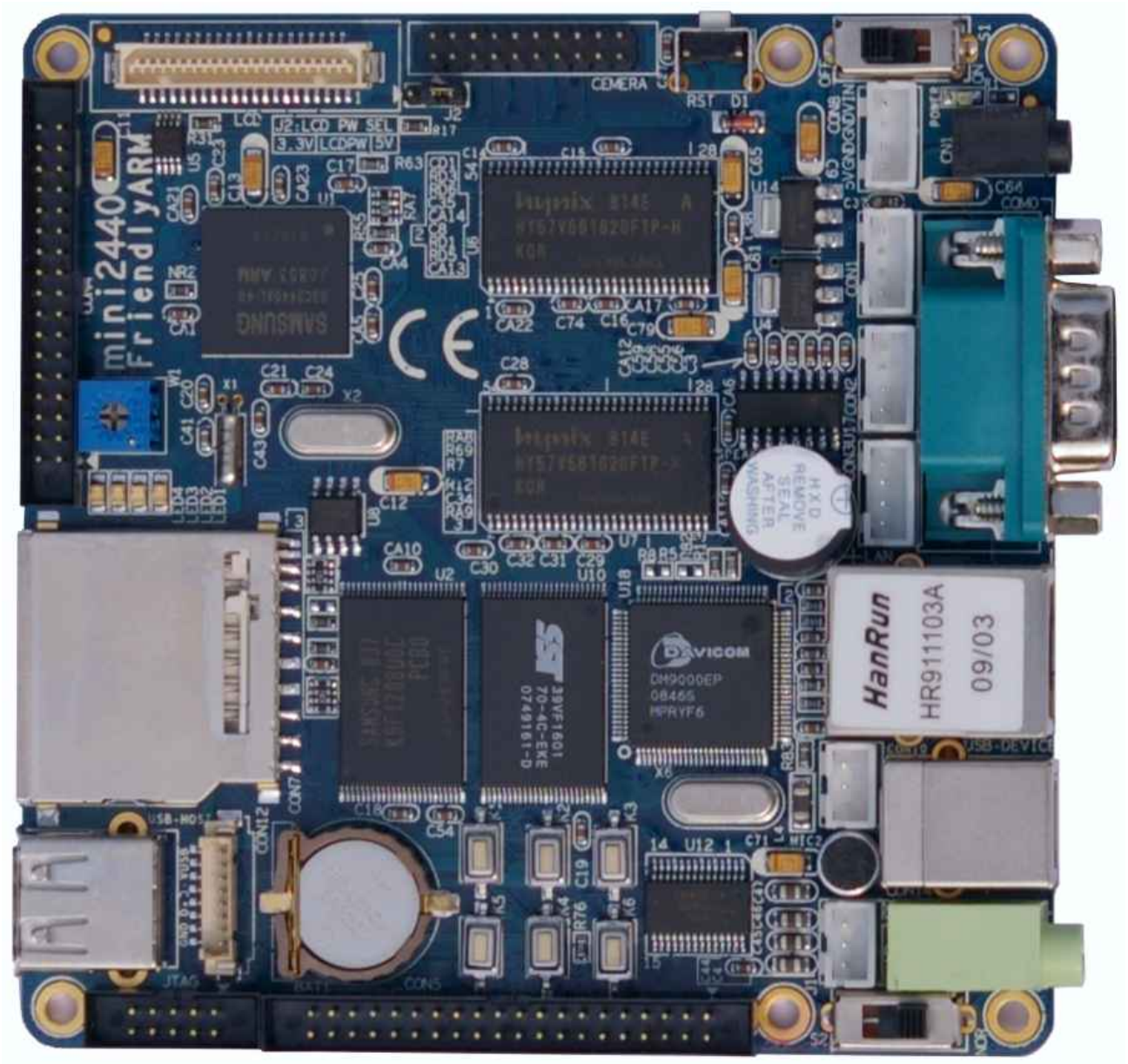

## 1.1 Features

### CPU

- Samsung S3C2440A (ARM920T), 400MHz, max. 533Mhz

### RAM

- 64MByte SDRAM
- 32bit Bus
- 100MHz Clock

### Flash

- 64MByte or 128MByte Nand Flash
- 2MByte Nor Flash with Bios

### System Clock

- 12Mhz Crystal

### LCD

- 4 wire resistive touch screen interface
- STN-Displays
  - 4bit dual scan, 4bit single scan or 8bit single scan display type
  - monochrome, 4 gray levels, 16 gray levels, 256 colors or 4096 colors
  - Max: 1024x768
- TFT-Display
  - 1, 2, 4 or 8 bpp palletized color displays
  - 16 or 24 bpp non-palletized true-color displays
  - Max: 1024x768, 64k colors

### Interface and Resource

- 1 10/100M Ethernet RJ-45 (DM9000)
- 3 Serial Ports (1 RS232)
- 1 USB Host
- 1 USB Device
- 1 SD-Card Interface
- 1 Audio Output
- 1 Audio Input
- 1 Microphone
- 4 User LEDs
- 6 User Buttons
- 1 PWM Buzzer
- 1 Adjustable Resistance (for ADC testing)
- 1 I2C EEPROM

- 1 Real Time Clock with Battery (RTC)
- 1 20pin Camera Interface (2.0mm)
- 1 34pin GPIO (2.0mm)
- 1 40pin System Bus (2.0mm)
- 1 10pin JTAG (2.0mm)

#### Power Supply

- 5V Connector

#### Dimension

- 10 x 10 cm

#### OS Support

- Linux 2.6
- Android
- Windows CE 5 and 6

## 2 Hardware Resource

### 2.1 Jumpers and Interfaces

- Switch (S1): Power on/off
- Switch (RST): Reset
- Switch (S2): Select boot mode (Nor Flash or Nand Flash)
- Jumper (J2): Select input voltage of the LCD driver board (3.3V or 5V)

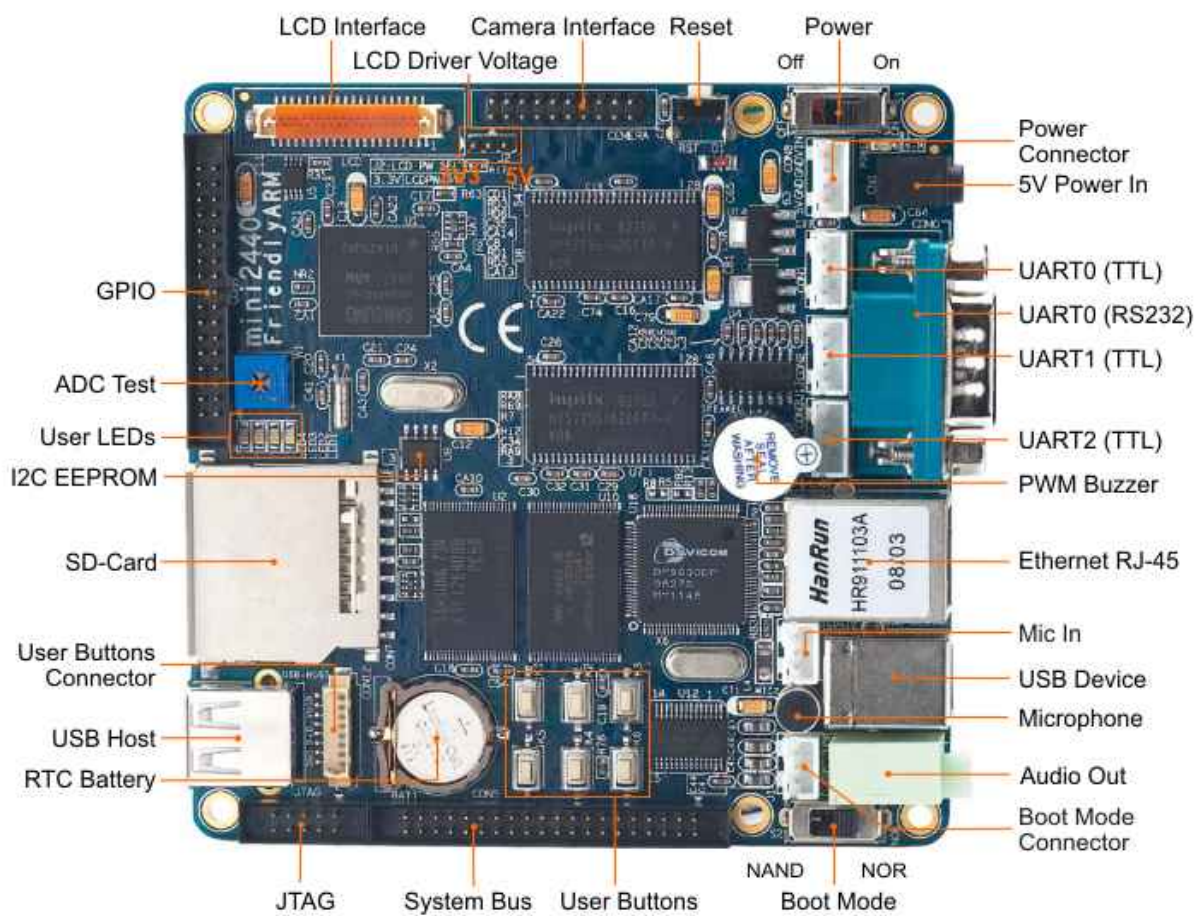

## 2.2 Memory Map

The S3C2440 supports two boot modes:

- booting from Nand Flash
- booting from Nor Flash

### 2.2.1 Memory Address Allocation

left: Nor Flash, right: Nand Flash

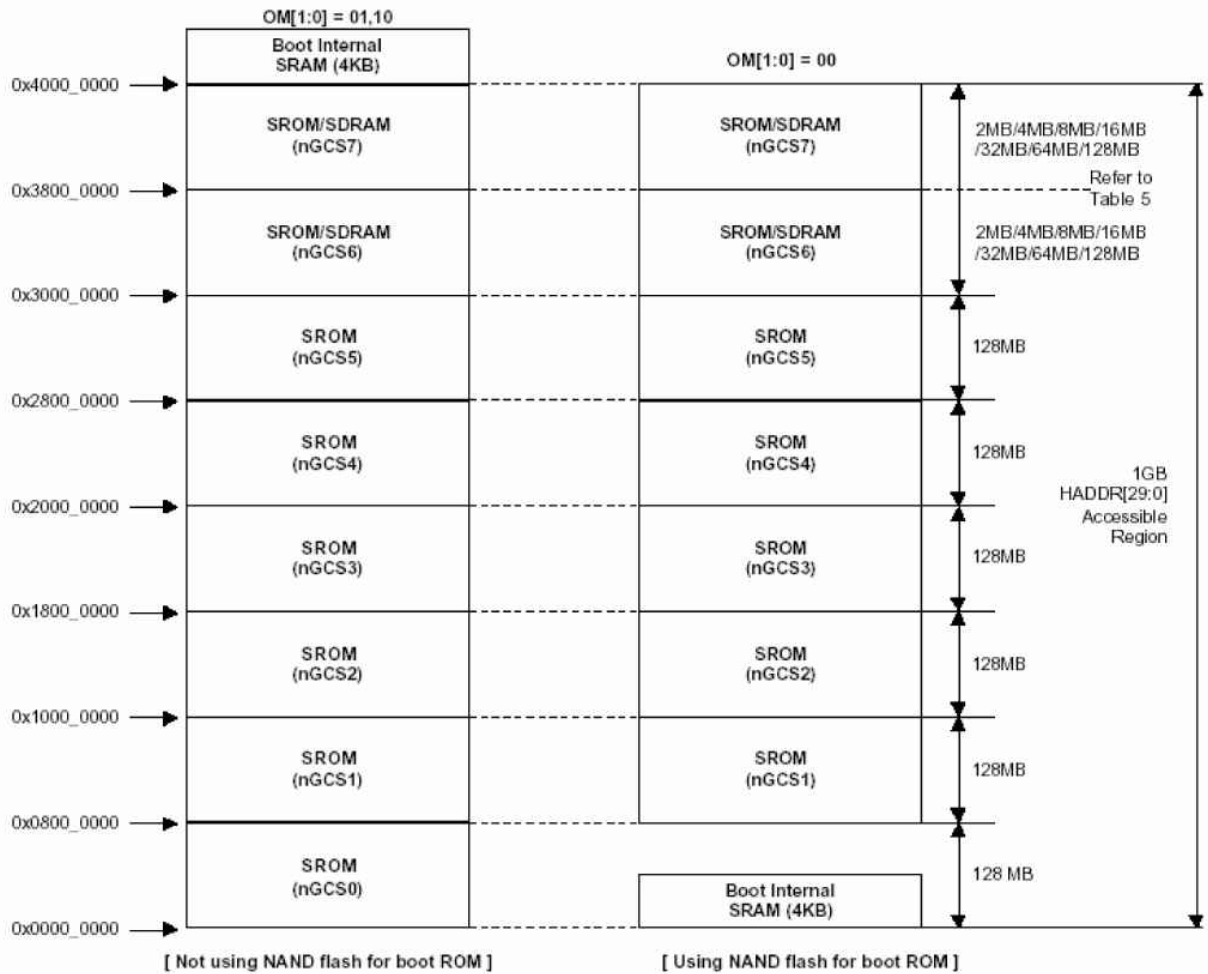

Nor Flash Boot: Nor Flash mapped to nGCS0 space

Nand Flash Boot: 4k Bytes Boot SRAM mapped to nGCS0 space

SDRAM address space: 0x30000000 - 0x34000000

There is one thing to note, nGCS0 chip select space is different in start-up mode, the mapping of the devices are not the same. In Nand Flash boot mode, the internal 4kBytes BootSRAM tablet is mapped to the nGCS0 space and in Nor Flash boot mode, the Nor Flash has been mapped to the chip select space nGCS0.

## 2.3 Power Supply

The board needs an external 5V power supply. The other required voltages are generated on the board: 3.3V, 1.8V and 1.25V.

## 2.4 System Reset

The reset circuit uses a MAX811 reset IC and there is an additional reset switch on the board: RST

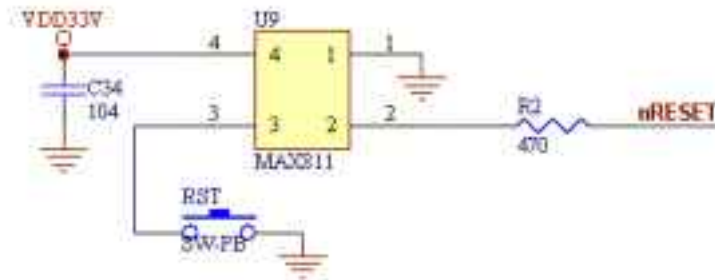

## 2.5 SDRAM

There are two 32MByte chips (HY57V561620, 4Banks x 4MBit x 16bit) on the board. The two 16bit chips form a 32bit data bus. Their physical start address is 0x30000000.

## 2.6 Flash

There are two flash memory types on the board: 2MByte Nor Flash (SST39VF1601) and 64MByte Nand Flash (K9F1208).

Address and data bus width:

- Nor Flash: 16bit Data + 20bit Address Bus
- Nand Flash: 8bit Data / Address Bus

## 2.7 User LEDs

LED	GPIO	Other function	Name in schematic
1	GPB5	nXBACK	nLED_1
2	GPB6	nXREQ	nLED_2
3	GPB7	nXDACK1	nLED_3
4	GPB8	nDREQ1	nLED_4

The LEDs are active low.



## 2.8 User Buttons

Button	GPIO	Other function	Name in schematic / interrupt
1	GPG0	-	EINT8
2	GPG3	nSS1	EINT11
3	GPG5	SPIMISO1	EINT13
4	GPG6	SPIMOSI1	EINT14
5	GPG7	SPICLK1	EINT15
6	GPG11	TCLK1	EINT19

The signal is low if a button is pressed.

The user buttons are also led out on CON12.

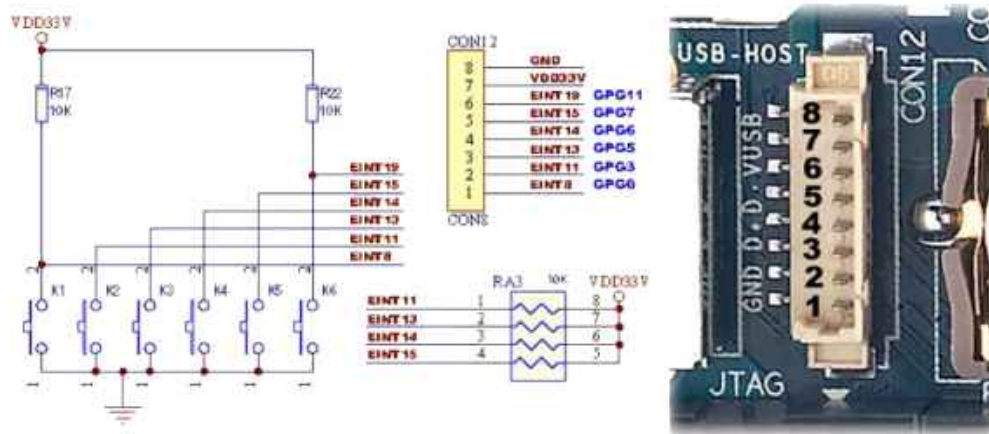

## 2.9 ADC

There are four ADC channels on the board which are connected to the GPIO header (CON4). AIN0 is also connected to a 10k potentiometer (W1).

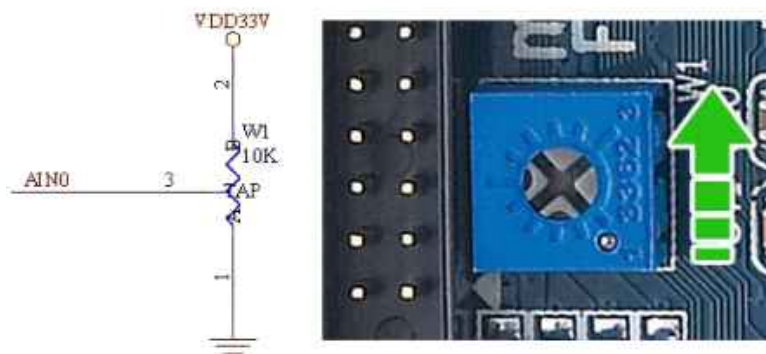

## 2.10 PWM Buzzer

The Buzzer is connected to GPB0.

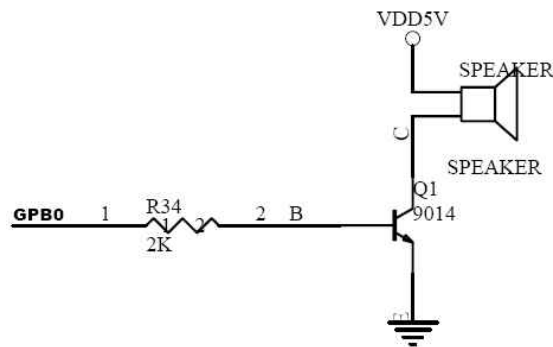

## 2.11 EEPROM

The 24C08 EEPROM (1024Byte) is connected to the I2C bus: I2CSCL and I2CSDA.

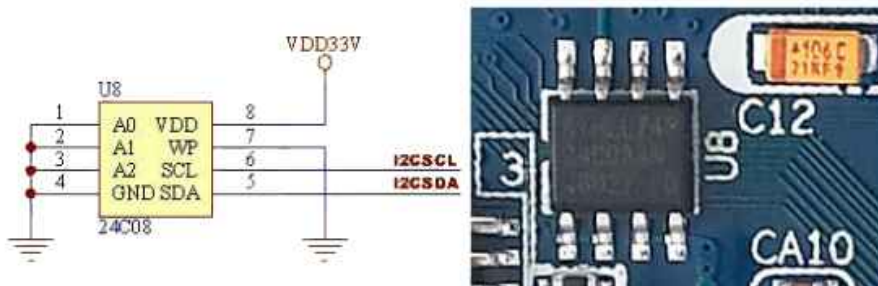

## 2.12 JTAG

The JTAG is led out on a 10 pin connector with 2.0mm pitch.

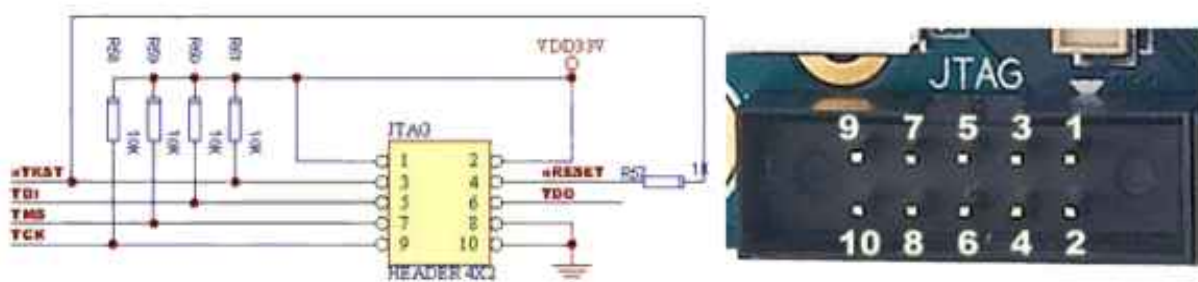

## 2.13 Ethernet

The ethernet interface uses a Davicom DM9000 chip.

Note: Each board has got the same MAC address. It can be configured by software for Linux and for WinCE inside the BSP DM9000 driver code.

## 2.14 UART

The three serial ports are led out on CON1 (UART0), CON2 (UART1) and CON3 (UART2). UART0 is also connected to a RS232 level converter and led out on COM0 (DB9 connector).

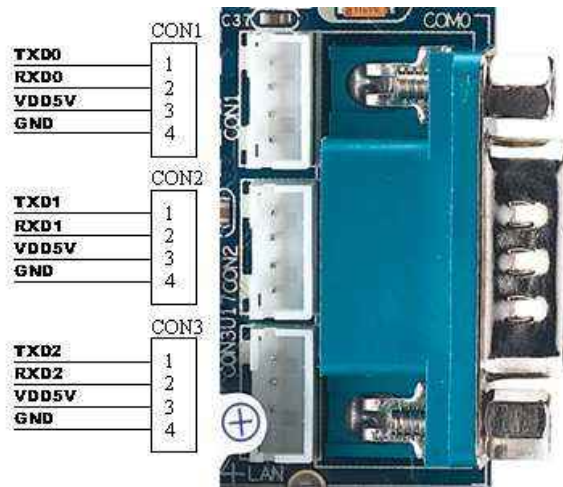

## 2.15 USB

The USB Host is a USB type A connector and the USB Device is a USB type B connector. For communication control the USB Device has got an additional pin: USB\_EN (GPC5).

## 2.16 LCD Interface

The board has got a 41 pin display connector (0.5mm pitch). All signals + a four-wire touch screen interface are on the connector.

The jumper J2 is used for the LCD driver board power supply select signal, either 5V or 3.3V supply.

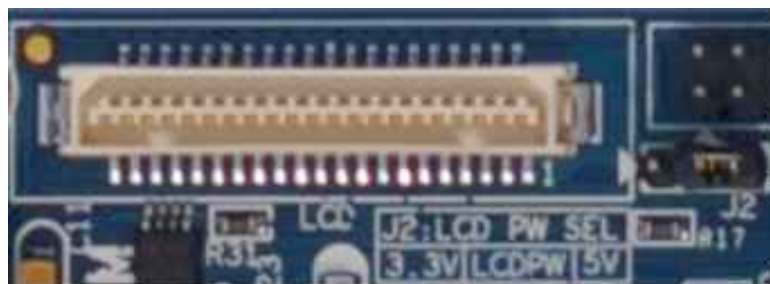

## **2.17 Camera Interface**

The S3C2440 device has a built-in CMOS camera interface and this can be accessed via CON20 (marked with CEMERA). It is a 20 pin 2.0mm pitch connector.

## **2.18 Audio In- and Output**

The used audio codec is a UDA1341 which is connected via I2S. The codec has one output and two inputs. The output is led out to the 3.5mm stereo jack. One input is connected to the on-board microphone and one is led out on CON10 (mono).

## **2.19 System Bus**

System Bus is on CON5, a 40 pin 2.0mm pitch connector.

## **2.20 GPIO**

GPIO is on CON4, a 34 pin 2.0mm pitch connector.