



actual size

# Oscillator · JO53 · 3.0 V

SMD Oscillator with Stop Function · 5.0 x 3.2 mm

- high temperature version available
- reflow soldering temperature: 260 °C max.
- ceramic/metal package



## General Data

<b>type</b>	<b>JO53 3.0 V</b>	
<b>frequency range</b>	0.50 ~ 125.0 MHz (15 pF max.)	
	0.50 ~ 50.0 MHz (30 pF max.)	
	2.00 ~ 50.0 MHz (15 pF max. for T2 & T3*)	
<b>frequency stability over all**</b>	± 20 ppm ~ ± 100 ppm (table 1)	
<b>current consumption</b>	see table 2	
<b>supply voltage V<sub>DC</sub></b>	3.0 V ± 5%	
<b>temperature</b>	<b>operating</b>	-10 °C ~ +70 °C
		-40 °C ~ +85 °C
		-40 °C ~ +105 °C
		-40 °C ~ +125 °C ask if available
<b>storage</b>	-55 °C ~ +125 °C	
<b>output</b>	<b>rise &amp; fall time</b>	see table 3
	<b>load max.</b>	15 pF / 30 pF (≤ +85 °C and ≤ 50.0 MHz)
	<b>current max.</b>	5 mA / 4 mA (T2 & T3*)
	<b>low level max.</b>	0.1 x V <sub>DC</sub> / 0.4 V (T2 & T3*)
	<b>high level min.</b>	0.9 x V <sub>DC</sub> / V <sub>DC</sub> - 0.4 V (T2 & T3*)
<b>output enable time max.</b>	10 ms	
<b>output disable time max.</b>	150 ns / 200 ns (T2 & T3*)	
<b>start-up time max.</b>	10 ms	
<b>standby function</b>	stop	
<b>standby current max.</b>	10 µA / 20 µA (T2 & T3*)	
<b>phase jitter 12 kHz ~ 20.0 MHz</b>	< 1.0 ps RMS	
<b>symmetry at 0.5 x V<sub>DC</sub></b>	45% ~ 55% (40% ~ 60% max.)	

\* ask if available

Table 1: Frequency Stability Code

stability code		A	B	G	C	D
		± 100 ppm	± 50 ppm	± 30 ppm	± 25 ppm	± 20 ppm
-20 °C ~ +70 °C	STD.		●	○	○	△
-40 °C ~ +85 °C	T1	●	●	○	○	
-40 °C ~ +105 °C	T2	○	○			
-40 °C ~ +125 °C	T3*	■				

● standard ○ available ■ ask if available △ excludes aging

\*\* includes stability at 25 °C, operating temp. range, supply voltage change, shock and vibration, aging 1st year.

Table 2: Current Consumption max.

Current at 15 pF load		Current at 30 pF load	
0.5 ~ 29.9 MHz	10 mA	0.5 ~ 29.9 MHz	10 mA
30.0 ~ 49.9 MHz	20 mA	30.0 ~ 50.0 MHz	25 mA
50.0 ~ 79.9 MHz	30 mA		
80.0 ~ 125.0 MHz	40 mA		

Table 3: Rise & Fall Time max.

at 15 pF	at 30 pF
6 ns: 0.50 ~ 1.79 MHz	7 ns: 0.50 ~ 50.00 MHz
5 ns: 1.80 ~ 49.99 MHz	
4 ns: 50.00 ~ 125.00 MHz	

**note:** rise time: 0.1 V<sub>DC</sub> ~ 0.9 V<sub>DC</sub> / fall time: 0.9 V<sub>DC</sub> ~ 0.1 V<sub>DC</sub>  
specific data on request

## Dimensions

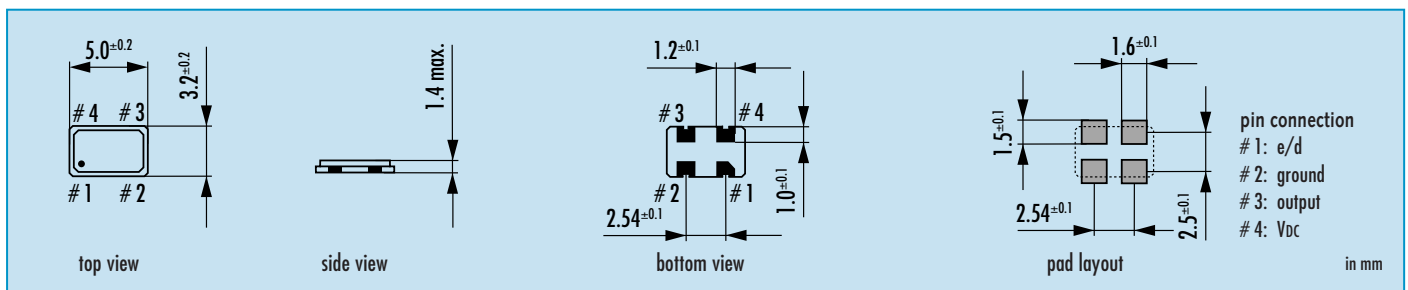

## Order Information

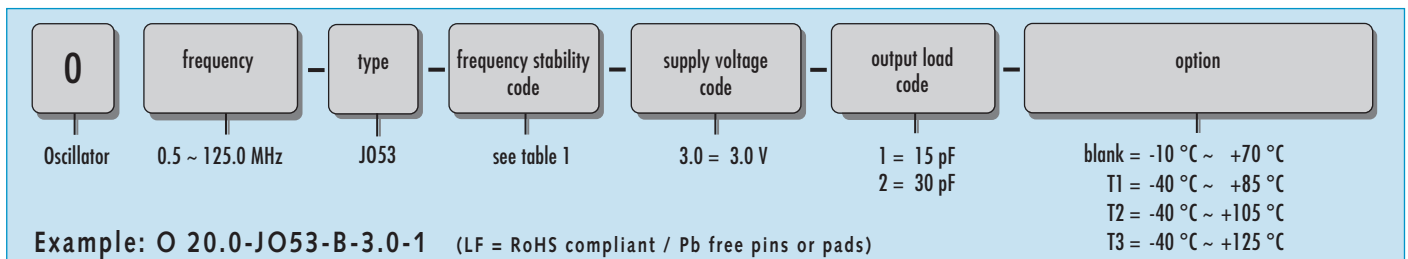

# Oscillator · JO53 · 3.0 V · Stop Function

## Taping Specification

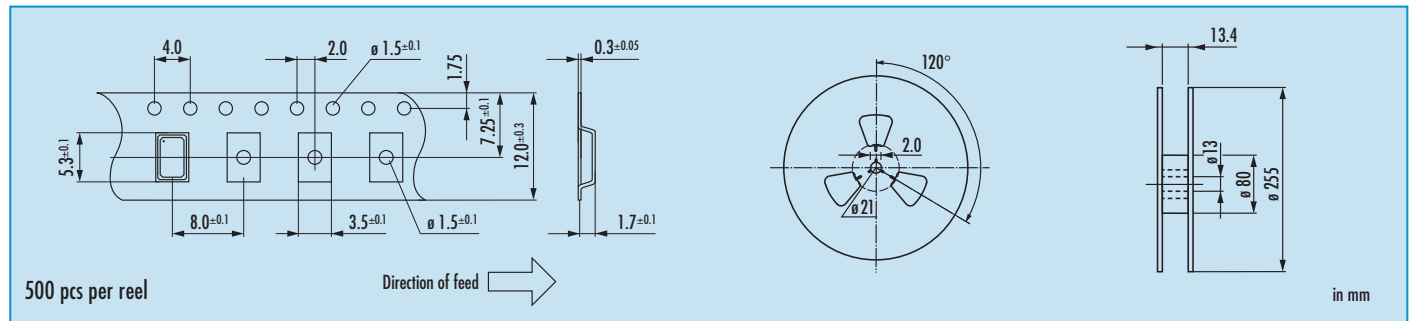

## Enable / Disable Function

<b>pin #1 (e/d control)</b>	<b>pin #3 (output)</b>
open	active
high "1" ( $V_{IH} \geq 0.8 V_{DC}$ )	active
low "0" ( $V_{IL} \leq 0.2 V_{DC}$ )	high impedance
<b>stop function:</b>	
<ul style="list-style-type: none"> <li>• oscillator stops</li> <li>• output high impedance</li> </ul>	

## Marking

frequency  
type / date code

date code:

A ~ M: Jan. - Dec.

2: 2012 5: 2015

3: 2013 6: 2016

4: 2014 7: 2017

Jan.	Febr.	Mar.	Apr.	May	June
A	B	C	D	E	F
July	Aug.	Sept.	Oct.	Nov.	Dec.
G	H	J	K	L	M

## Reflow Soldering Profile

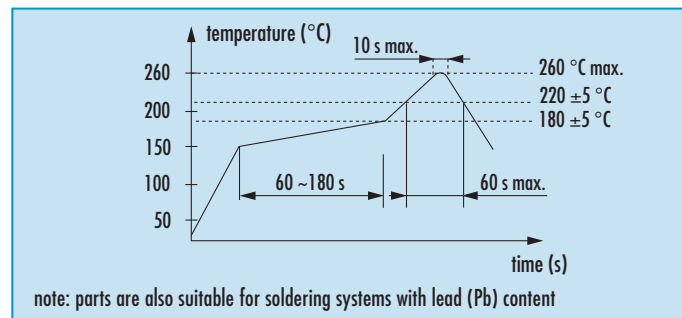

## Packing Note

- standard packing units are 500 pieces per reel
- non-multiple packing units are only supplied taped / bulk